



1. Electrical Parameters

MODEL: O23B-1202-10.00MHZ						
Item	Description	Parameters			Unit	Test Condition
		Min.	Typ.	Max.		
Output	Frequency	10.00			MHz	
	Output Waveform	HCMOS				
	Output Low Voltage			0.4	V	$V_{cc}=5.0V, O_{load}=15pF$
	Output High Voltage	2.4			V	$V_{cc}=5.0V, O_{load}=15pF$
	Duty Cycle	45	50	55	%	@50%
	Rise / Fall Time (10%~90%)			6	ns	
	Load	15			pF	
	Start up time		0.7	1	s	
Frequency Stabilities	Frequency Tolerance vs. Operating Temperature Range	-0.2		+0.2	$\times 10^{-9}$	T_A varied from $-40^{\circ}C$ to $85^{\circ}C$, measurement referenced to frequency observed with $f_{ref}=(f_{max}+f_{min})/2, V_{cc}=5.0V, O_{load}=15pF$, temperature variable speed less than $2^{\circ}C$ per minute.
	Initial Frequency Tolerance	-0.05		+0.05	$\times 10^{-6}$	Measurement referenced to frequency observed with $T_A=25^{\circ}C, V_{cc}=5.0V, DAC=0x7FFF$, and after 30 minutes of operation.
	Frequency Tolerance vs. Supply Voltage	-0.1		+0.1	$\times 10^{-9}$	Measurement referenced to frequency observed $T_A=25^{\circ}C, V_{cc}$ varied from 4.75V to 5.25V, and $O_{Load}=15pF$.
	Frequency Tolerance vs. Load	-0.1		+0.1	$\times 10^{-9}$	10% load change measurement referenced to frequency observed with $T_A=25^{\circ}C, V_{cc}=5.0V$, and $O_{Load}=15pF$.
	Short-Term Stability: Allan Variance			0.005	$\times 10^{-9}$	Temperature stability, no EMI\EMC or other interference, test after power for 1hour ref. to $25^{\circ}C$; 1s, using PN9000 equipment.
	Aging Tolerance Per Day	-0.2		+0.2	$\times 10^{-9}$	V_{cc}, T_A constant measurement referenced to frequency observed with $T_A=25^{\circ}C, V_{cc}=5.0V$, before shipment.
	Aging Tolerance 1 Year	-0.02		+0.02	$\times 10^{-6}$	
Power Supply	Supply Voltage	4.75	5.0	5.25	V	
	Steady Consumption			700	mA	@ $25^{\circ}C$
	Warm up current			1500	mA	
	Warm-Up Time			5	min	@ $25^{\circ}C$ within $\pm 0.01 \times 10^{-6}$ of final frequency with reference after 1 hour on.



DAC Control Characteristics	Frequency Tuning Range	-0.5		-0.2	$\times 10^{-6}$	DAC=0x0000. measurement referenced to DAC=0x7FFF
		-0.05		+0.05	$\times 10^{-6}$	DAC=0x7FFF. measurement referenced to Exactly 10.00MHz
		+0.2		+0.5	$\times 10^{-6}$	DAC=0xFFFF. measurement referenced to DAC=0x7FFF
	Linearity			10	%	
	Slope	Positive				
	Input Impedance	100			K Ω	
Phase Noise	Phase Noise		-130	-120	dBc/Hz	10Hz
			-145	-135		100Hz
			-150	-145		1KHz
			-150	-145		10KHz
			-150	-145		100KHz
			-150	-145		1MHz
Environmental Conditions	Operable Temperature	-40		+85	$^{\circ}\text{C}$	
	Storage Temperature	-55		+105	$^{\circ}\text{C}$	
	ESD Level	Human Body Model, class2: 2000V to 4000V; ANSI/ESDA/JEDEC JS-001-2010.				
		Machine Model, class B: 200V to 400V; ANSI/ESDA/JEDEC JS-001-2010.				
	Moisture Sensitivity Level	Not humidity sensitive.				
	Vibration	Test Condition: 0.75mm ;acceleration:10g;10Hz~500Hz, one cycle per 30 min, test 2 hour. (3 times for each 3 directions X , Y , Z), IEC 68-2-06 Test Fc.				
Shock	50g; 11ms; half sine wave (3 times for each 3 directions X, Y, Z), IEC 68-2-27 Test Ea/Severity 50A.					
Full Package Storage	Relative humidity (%)	20%~70%				
	Temperature ($^{\circ}\text{C}$)	-10~35 $^{\circ}\text{C}$				



2. Mechanical Structure (mm)

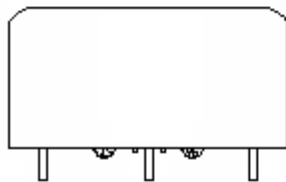
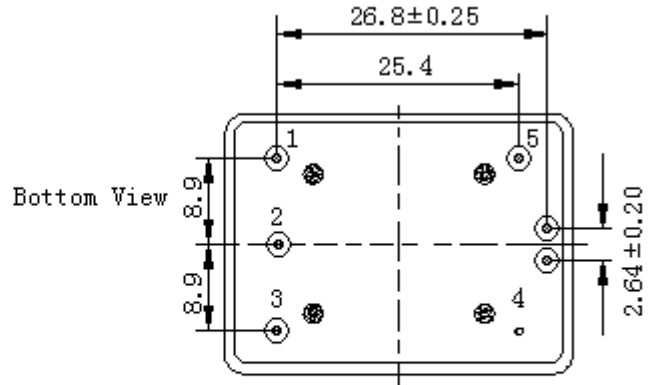

Right View

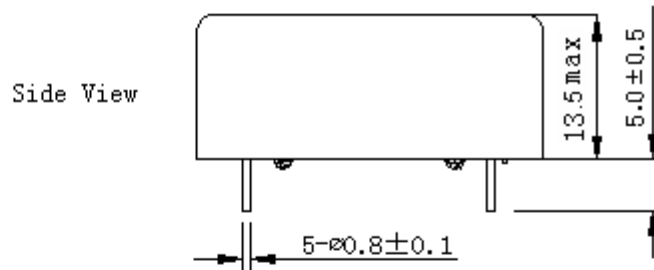

Side View

PIN FUNCTION

PIN	FUNCTION
1	VCC
2	SDA
3	SCL
4	GND
5	OUTPUT

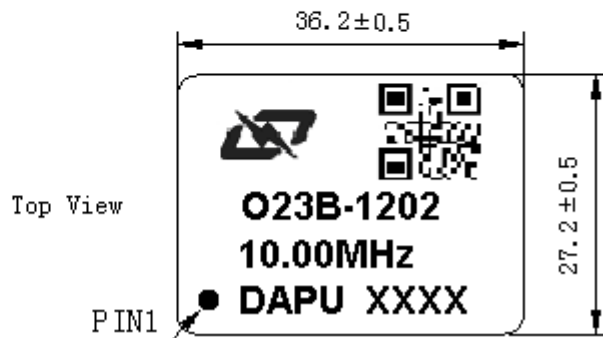

Top View

Note1: Tolerance ± 0.20 mm without mark

Note2: The first two xx representative: week
After two xx representative: year

Note3: Referential weight 20.7g



3. I²C Devices Address

3.1 DIGITAL-TO-ANALOG CONVERTER,VOLTAGE OUTPUT

Device name : DAC8571

Device supplier : TI

Device address : 1001100

4. Test Circuit

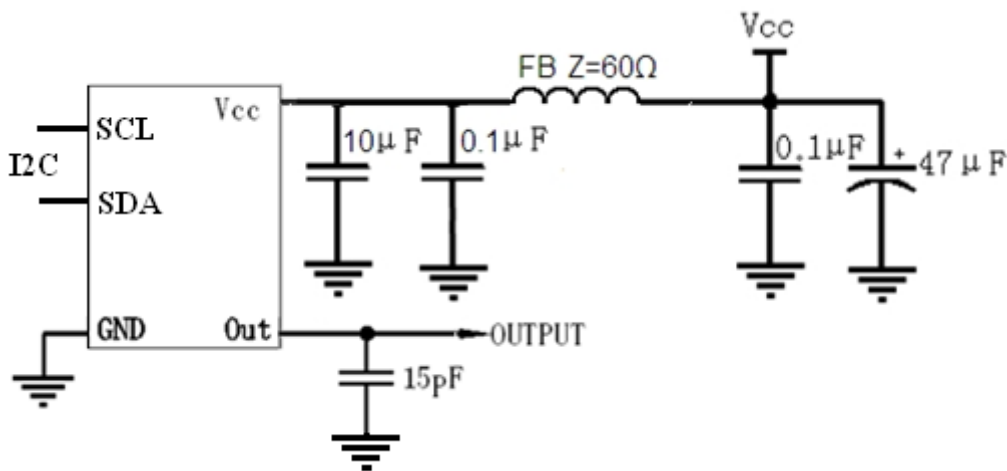

5. Reflow Soldering Curve (RoHS)

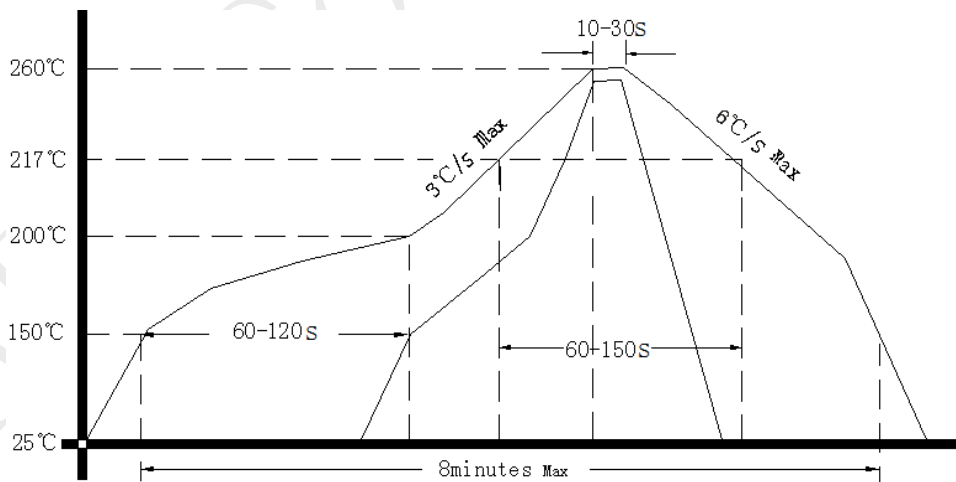



6. Package (mm)

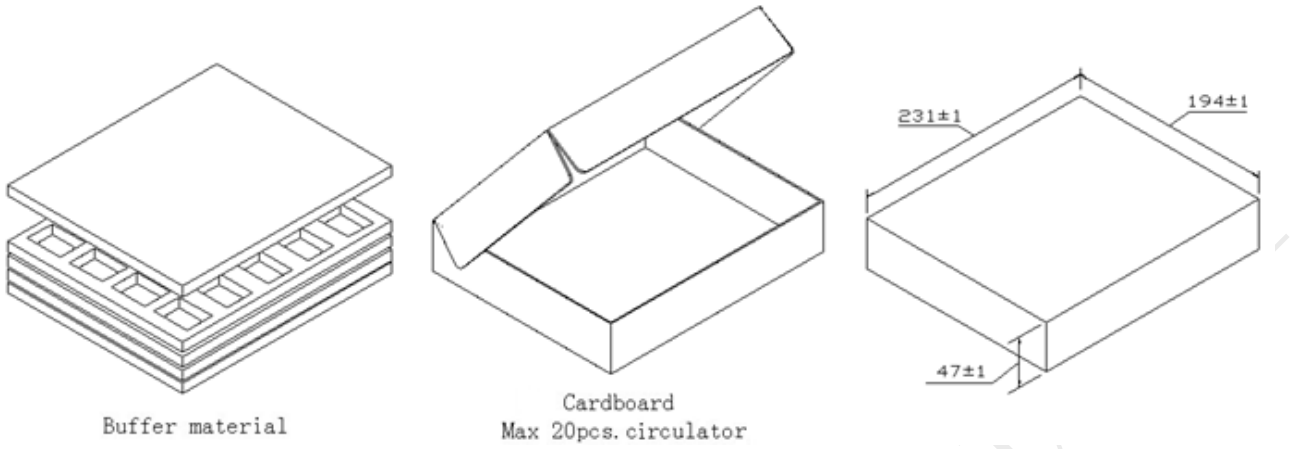

DAPU Confidential