

Travelling Merchant: _____

DATASHEET

Standard: DP7W16380001

Plot			The Label
Drew	Audited	Approved	Stamp, please! Thanks!
Date: 2017.10.09			

Guangdong Dapu Telecom Technology Co.,Ltd

Bldg13,.N.Ind.Zone,SSL Industry Park, Dongguan City, Guangdong Province, China

TEL: 0086-0769-88010888 FAX: 0086-0769-81800098



1、Electrical Parameters

MODEL: DP7W16380001							
No.	Parameters	SYM.	Electrical Spec.				Notes
			Min.	Typ.	Max.	Units	
1	Nominal Frequency	FL	16.384			MHz	
2	Frequency Stability	-	-50		+50	ppm	
3	Operating Temperature	Topr	-40		85	°C	
4	Storage Temperature	Tstg	-55	~	125	°C	
5	Supply Voltage	VDD	2.97	3.3	3.63	V	
6	Input Current	Icc	-	-	15	mA	
7	Enable Control	-	Yes			-	
8	Output Load: CMOS	CL	15			pF	
9	Output Voltage High	VoH	90% Vdd	-	-	V	
10	Output Voltage Low	Vol	-	-	10% Vdd	V	
11	Rise Time	Tr	-	-	5	ns	10%-90% VDD Level
12	Fall Time	Tf	-	-	5	ns	90%-10% VDD Level
13	Symmetry (Duty ratio)	TH/T	45	~	55	%	
14	Start-up Time	Tosc	-	-	10	ms	
15	Enable Voltage High	Vhi	70% Vdd	-	-	V	
16	Disable Voltage Low	Vlo	-	-	30% Vdd	V	
17	Aging	-	±3			ppm/yr.	1st. Year at 25°C
18	Drop Test	75 cm height,3 times on concrete floor .					JIS C6701
19	Mechanical Shock	Device are shocked to half sine wave (1000 G) three mutually. perpendicular axes each 3 times. 0.5m sec. duration time					MIL-STD-202F
20	Vibration	Frequency range 10 ~ 2000 Hz Amplitude 1.52 mm/20G Sweep time 20 minute perpendicular axes each test time 4 hours (Total test time 12 hours)					MIL-STD-883E



2、 Mechanical Structure(mm)

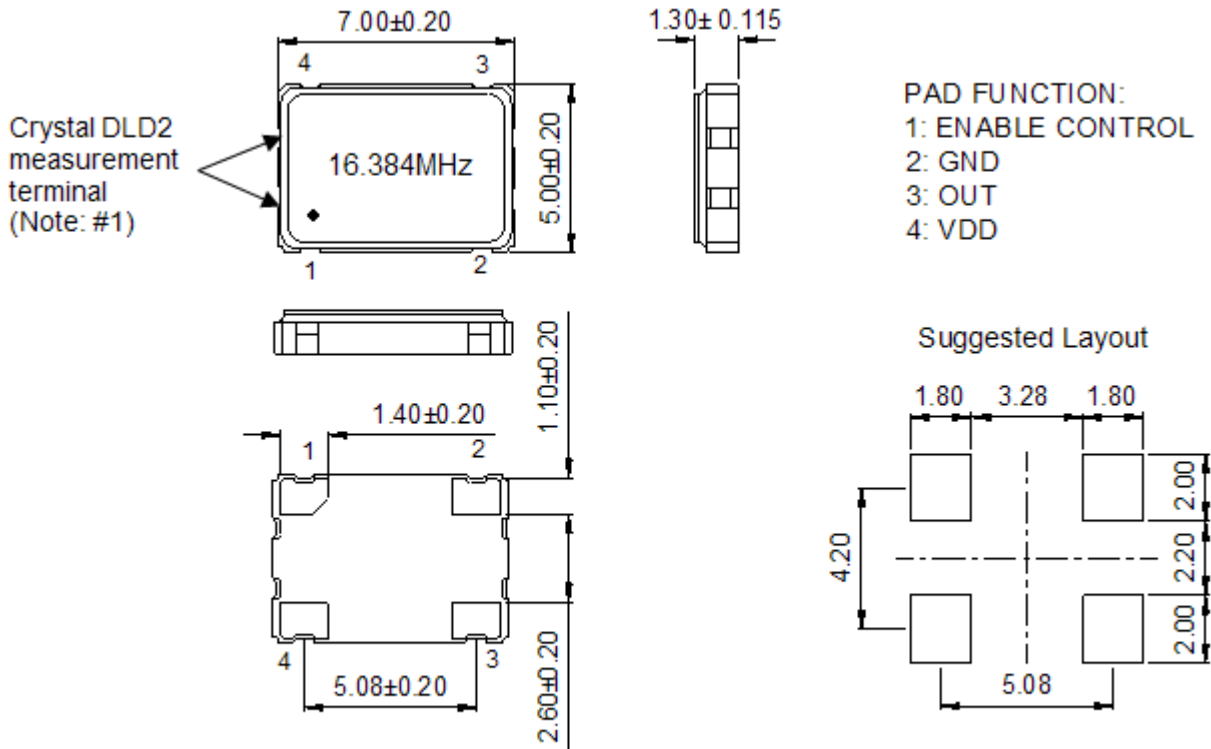

Note: #1. DLD2 / Drive Level Dependency 2 Maximum resistance minus minimum resistance.

3、 Test Diagram

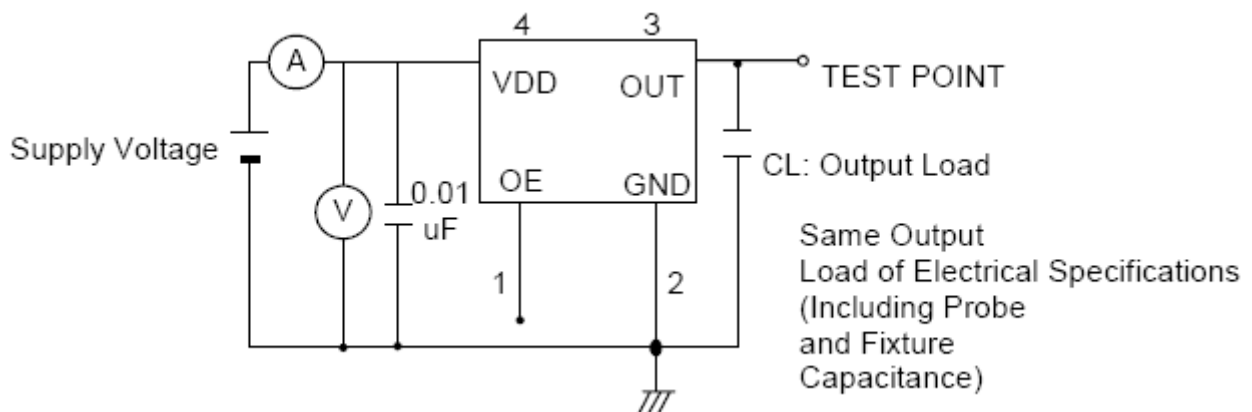

Control input (output enable/disable)

Logic 1 or open on pad 1: Oscillator output

Logic 0 on pad 1 : Disable output to high impedance



4、 Reflow Soldering Curve (RoHS)

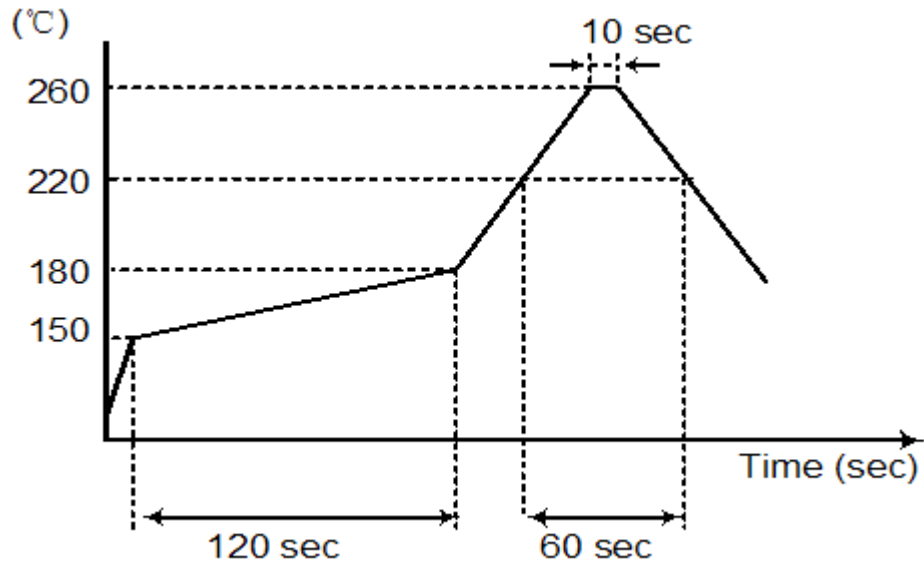

5、 Package: Tape & Reel (mm)

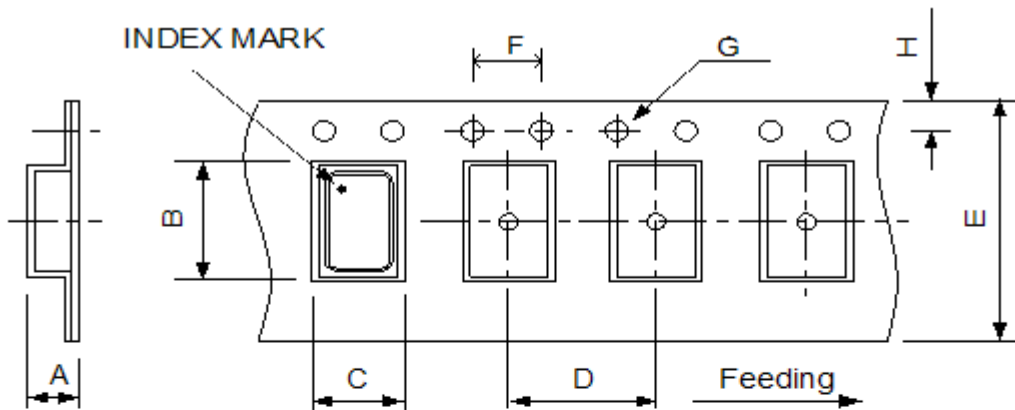

DIMENSIONS	A	B	C	D	E	F	G	H	
	2.00	7.90	5.45	8.00	16.00	4.00	1.50	1.75	(UNIT : mm)

REMARK :

