

Travelling Merchant: _____

DATASHEET

Standard: CM65E-D129-10.00MHz

P/N: _____

Plot			The Label
Drew	Audited	Approved	Stamp, please! Thanks!
<i>Anway.wei</i>	<i>Carry.wang</i>	<i>James.Liu</i>	
Date: 2017.05.25			

Guangdong Dapu Telecom Technology Co.,Ltd

Bldg13-16,.N.Ind.Zone,SSL Industry Park, Dongguan City, Guangdong Province, China

TEL: 0086-0769-88010888 FAX: 0086-0769-81800098



1. Description

The CM65E-D129 is a high holdover performance, high integration clock module with patent compensated algorithm. After 2 days PRC level reference locking, it can achieve better than 1E-12 frequency stability and holdover for 24 hours within $\pm 1.5\mu\text{s}$ ($\pm 5^\circ\text{C}$).

The CM65E-D129 provides many kinds of maintenance and alarm messages output to improve the reliability and maintainability of the network.

The CM65E-D129 has a built-in GPS Receiver to provide the reference clock and TOD messages.

The CM65E-D129 is ideal for high performance frequency and time reference in wireline Telecommunications, wireless Telecommunications, substations, Test and Measurement Applications. It is the perfect replacement for rubidium clock.

2. Feature

- Built-in GPS satellite receiver, GPS/GLONASS/BEIDOU/GALILEO Optional
- Ultra-High holdover ability close to Rubidium Clock
 - Better than $\pm 1.5\mu\text{s}@24$ hours ($\pm 5^\circ\text{C}$) holdover
 - Better than $\pm 2.4\mu\text{s}@24$ hours ($\pm 10^\circ\text{C}$) holdover
 - Better than $\pm 4.1\mu\text{s}@24$ hours ($\pm 20^\circ\text{C}$) holdover
- Combine high stability OCXO and patent compensated algorithm
- High integration and small size (65mm×65mm×18mm)
- Various kinds of maintenance and alarm messages output
- 5V operation and low power consumption



3. Functional Block Diagram

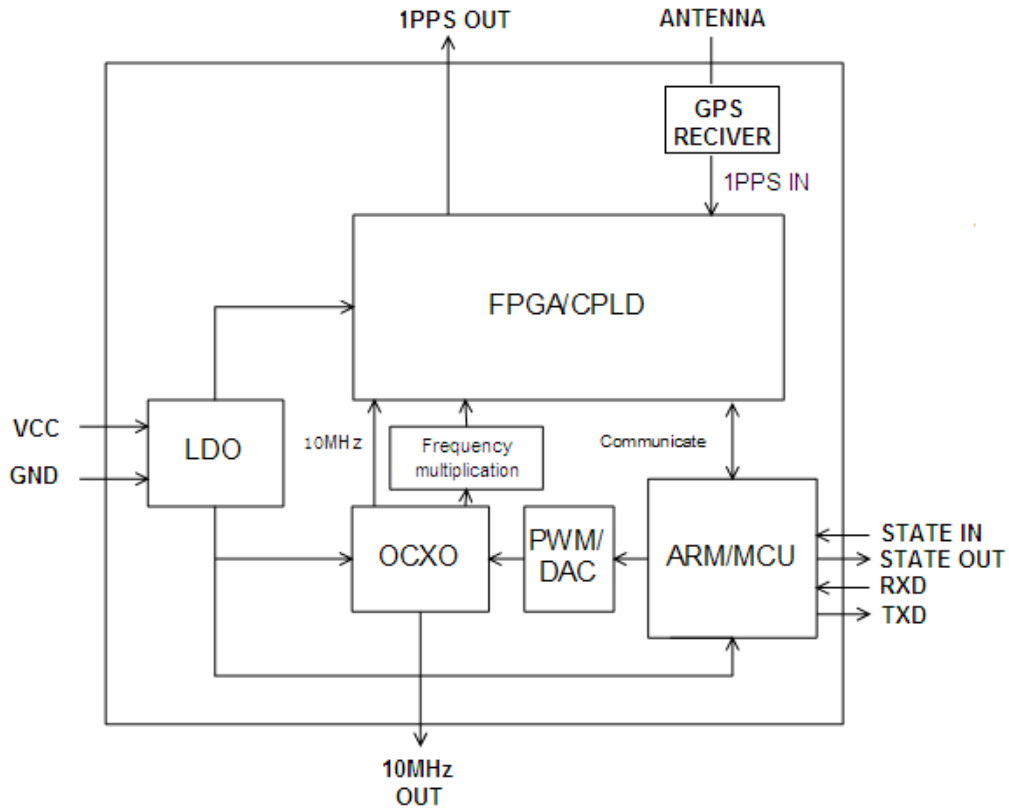



4. Workflow Diagram

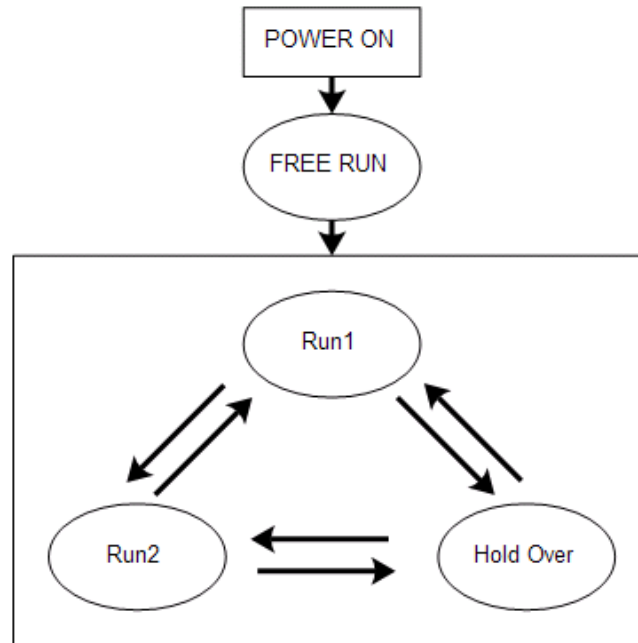

Run1: Fast track. Adjust the OCXO 10MHz output frequency quickly to track the local 1PPS with the GPS 1PPS.

Run2: Slow track. Adjust the OCXO 10MHz output frequency slowly when the phase error is in the defined range.

Holdover: when GPS is lost, an algorithm has been developed which enables adaptive modeling of the frequency stability of an OCXO with reference to a GPS timing signal.

Free Run: Clock module power on without 1PPS reference anyway.

5. Applications

- Wireless base station
- Telecom Synchronization Network
- Power Grid Substation
- Test and Measurement
- Military/Aerospace



6. Electrical Parameters

Internal Receiver Characteristics	PARAMETERS						NOTES
	Type	Auto Position Lock					
	Number Of Channels	50					
	Frequency Band	L1 (1575.42 MHz)					
	Tracking Code	C/A Code					
	Tracking Capability	12 Satellites					
	Sensitivity	Tracking & Navigation		-162dBm			
		Reacquisition		-157dBm			
		Cold Start (Autonomous)		-148dBm			
	Antenna Input	SMA-KE				CN1	
Antenna Supply Voltage	5V						
State Input	Parameters	Min.	Typ.	Max.	Unit.		
	Lock Enable	2.7			V	<5mA Load	
	Lock Disable			0.4	V	<5mA Load	
	Connector	Pin 8					
RF Output	Parameters	Min.	Typ.	Max.	Unit.	Test Condition	
	Nominal Frequency	10.00			MHz		
	Waveform	HCMOS					
	High-level Output Voltage (V_{OH})	2.7			V	< 5mA Load	
	Low-level Output Voltage (V_{OL})			0.4	V	< 5mA Load	
	Rise/Fall Time		4	8	ns	< 5mA Load	
	Duty Cycle	45	50	55	%	< 5mA Load	
	Frequency Tolerance vs. Operating Temperature Range	-0.02		+0.02	$\times 10^{-9}$	TA varied from -20°C to 75°C, measurement referenced to frequency observed with TA= 25°C, Vcc=5.0V, O _{Load} =15pF. Temperature change rate less than 1°C per minute.	
	Frequency Tolerance vs. Supply Voltage	-0.01		+0.01	$\times 10^{-9}$	measurement referenced to frequency observed T _A =25°C, V _{cc} varied from 4.75V to 5.25V, and O _{Load} =15pF.	
	Retrace	-5		+5	$\times 10^{-9}$	@25°C, frequency variation measured after 48 hours power off and 3 hours power on, referred to stable frequency before power off.	



	Short-term Stability			0.02	$\times 10^{-9}$	Temperature stability, no EMI/EMC or other interference, test after power for 1 hour ref. to 25°C; 1s, using PN9000 equipment.	
	Aging Tolerance Per Day	-0.2		+0.2	$\times 10^{-9}$	Vcc, TA constant measurement referenced to frequency observed with TA=25°C, Vcc=5.0V, in FREE RUN condition and after 30 days of operation.	
	Aging Tolerance 1 Year	-0.01		+0.01	$\times 10^{-6}$		
	Phase Noise (All conditions)			-118	-113	dBc/Hz	10Hz
				-138	-133		100Hz
				-148	-143		1KHz
				-150	-145		10KHz
				-150	-145		100KHz
			-150	-150	1MHz		
Connector	Pin 2						
GPS 1PPS Output	Parameters	Min.	Typ.	Max.	Unit.	Test Condition	
	Waveform	HCMOS					
	High-Level Output Voltage (V _{IH})	2.7			V		
	Low-Level Output Voltage (V _{IL})			0.4	V		
	Pulse Width		100		ms		
	Connector	Pin 10					
State Output	Parameters	Min.	Typ.	Max.	Unit.	Test Condition	
	High-Level	2.7			V	<5mA Load	
	Low-Level			0.4	V	<5mA Load	
	Connector	Pin 5					
Holdover Capability	Holdover Time	Min.	Typ.	Max.	Unit.	Test Condition (Temperature change rate less than 1°C per minute)	
	24 Hours	-1.5		+1.5	μs	ΔT = ±5°C, 24 hours holdover after power on 7days and lock 2days.	
		-2.4		+2.4	μs	ΔT = ±10°C, 24 hours holdover after power on 7days and lock 2days.	
		-4.1		+4.1	μs	ΔT = ±20°C, 24 hours holdover after power on 7days and lock 2days.	



		-3.0		+3.0	μs	ΔT = ±5°C, 24 hours holdover after power on 4~6days and lock 2days.	
		-3.9		+3.9	μs	ΔT = ±10°C, 24 hours holdover after power on 4~6days and lock 2days.	
		-5.6		+5.6	μs	ΔT = ±20°C, 24 hours holdover after power on 4~6days and lock 2days.	
		-8.0		+8.0	μs	ΔT = ±5°C, 24 hours holdover after power on 2 days and lock 2days.	
		-8.9		+8.9	μs	ΔT = ±10°C, 24 hours holdover after power on 2 days and lock 2days.	
		-10.6		+10.6	μs	ΔT = ±20°C, 24 hours holdover after power on 2 days and lock 2days.	
	10s	-0.05		0.05	μs	ΔT = ±5°C, 24 hours holdover after power on 4 hours and lock 4 hours.	
	1hour	-1.0		1.0	μs		
	3hours	-4.0		4.0	μs		
Frequency Stability	Test time	Min.	Typ.	Max.	Unit.	Test Condition	
	10s			0.6	ppb	Average frequency stability after power on 4 hours and lock 4 hours.	
	1hour			0.1	ppb		
	3hours			0.08	ppb		
	24 hours			0.01	ppb	Average frequency stability after power on 24 hours and lock 24 hours.	
	24 hours			0.001	ppb	Average frequency stability after power on 48 hours and lock 48 hours.	
Supply Voltage	Parameters	Min.	Typ.	Max.	Unit.		
	Supply voltage	4.75	5.0	5.25	V		
	Warm up time			15	mins		
	Current consumption				2500	mA	During Warm-up
					1000	mA	During steady state operation @25°C
	AC ripple			50	mVpk-pk	10Hz to 1MHz	
Connector	Pin 12						
1 PPS Output Waveform Characteristics	Parameters	Min.	Typ.	Max.	Unit.	Test Condition	
	Waveform	HCMOS					
	High-Level Output Voltage(V _{OH})	2.7			V		



	Low-level Output voltage (V_{OL})			0.4	V	
	Pulse Width		100		ms	
	Phase Accuracy	-200		+200	ns	Initial lock status (the first 30mins after the first time CM65 got locked to the 1PPS ,tested time ≥ 30 mins)
		-80		+80	ns	lock status (locked time ≥ 30 mins, tested time ≥ 60 mins, under the condition of 1PPS reference RMS ≤ 30 ns)
	Phase Accuracy (RMS)			25	ns	Steady lock status (locked time ≥ 24 hours, tested time ≥ 24 hours, under the condition of 1PPS reference RMS ≤ 30 ns)
Connector	Pin 3					
Serial Interfaces	Parameters	Min.	Typ.	Max.	Unit.	Test Condition
	Rx high-level Input Voltage (VH)	2.7			V	
	Rx low-level Input Voltage (VL)			0.4	V	
	Tx high-level Output Voltage (VH)	2.7			V	
	Tx low-level Output Voltage (VL)			0.4	V	
	Serial Protocol	9600-N-8-1				
	Connector	Pin6 and Pin7				
Environmental Conditions	Parameter	Conditions				
	Operating temperature	-20°C to +75°C				
	Storage Temperature	-55°C to +105°C				
	Storage humidity	30%~80%				
	ESD Level	Human Body Model,class2: 2000V to 4000V; ANSI/ESDA/JEDEC JS-001-2010.				
		Machine Model, class B: 200V to 400V; ANSI/ESDA/JEDEC JS-001-2010.				
	Moisture Sensitivity Level	Not humidity sensitive.				
	Vibration	Test Condition: 0.75mm ;acceleration:10g;10Hz~500Hz, one cycle per 30 min, test 2 hour. (3 times for each 3 directions X , Y , Z), IEC 68-2-06 Test Fc.				
Shock	50g; 11ms; half sine wave (3 times for each 3 directions X , Y , Z),IEC 68-2-27 Test Ea/Severity 50A.					



7. Typical Application

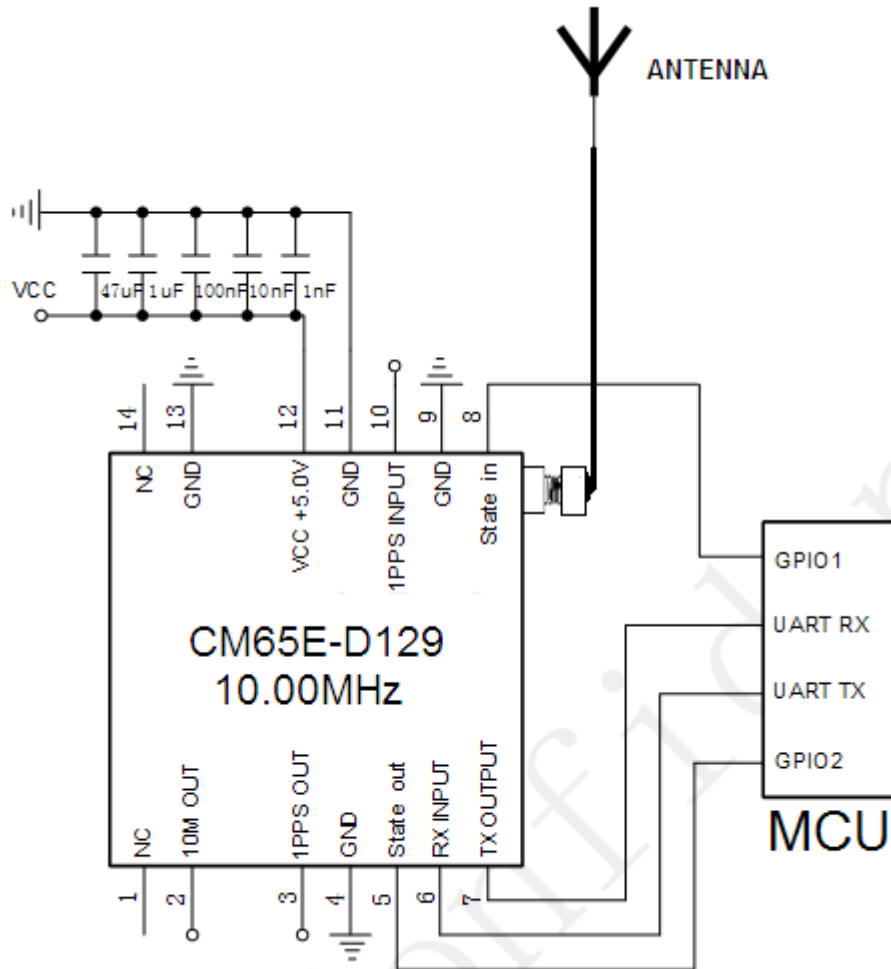



8. MTIE And TDEV In Lock Mode (ITU G.811 Figure 1 and Figure 2)

Test Condition: after power on and lock to GPS 1 hour, TA=25°C, ΔT = ±1°C, airflow=1m/s.

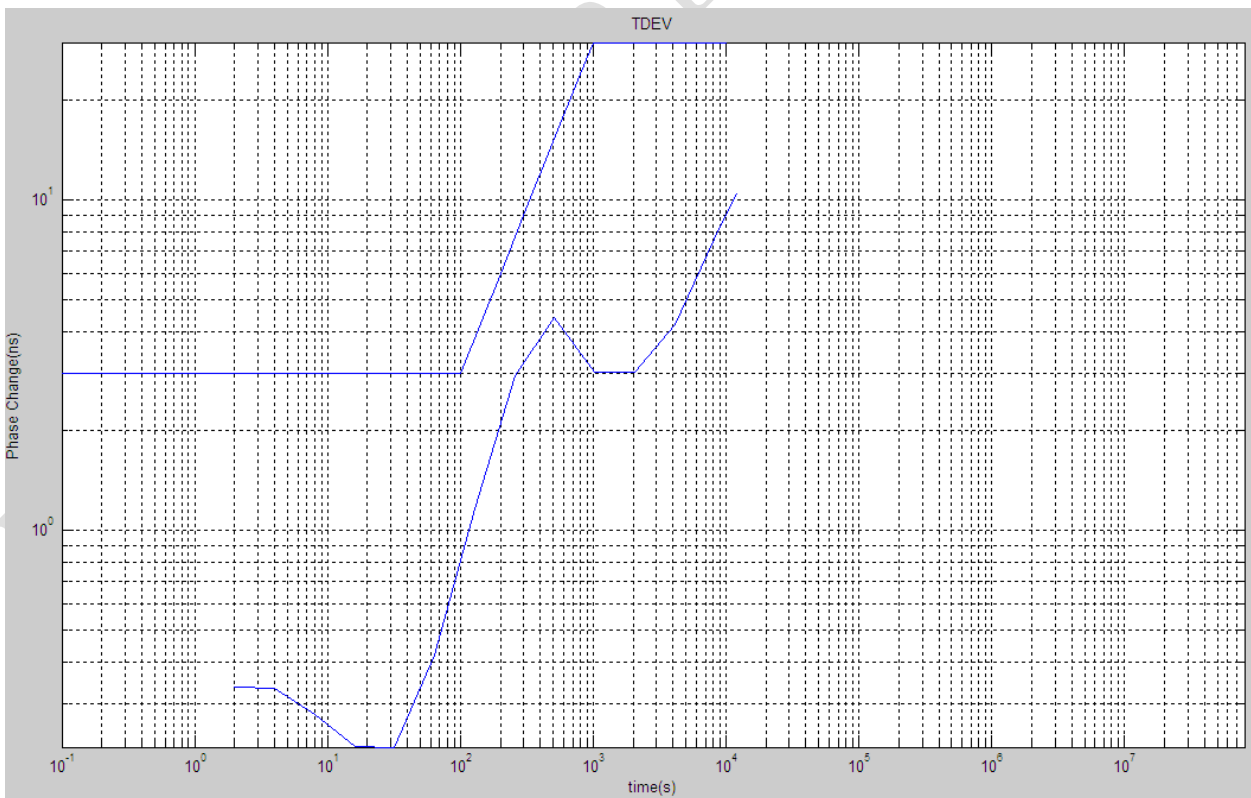
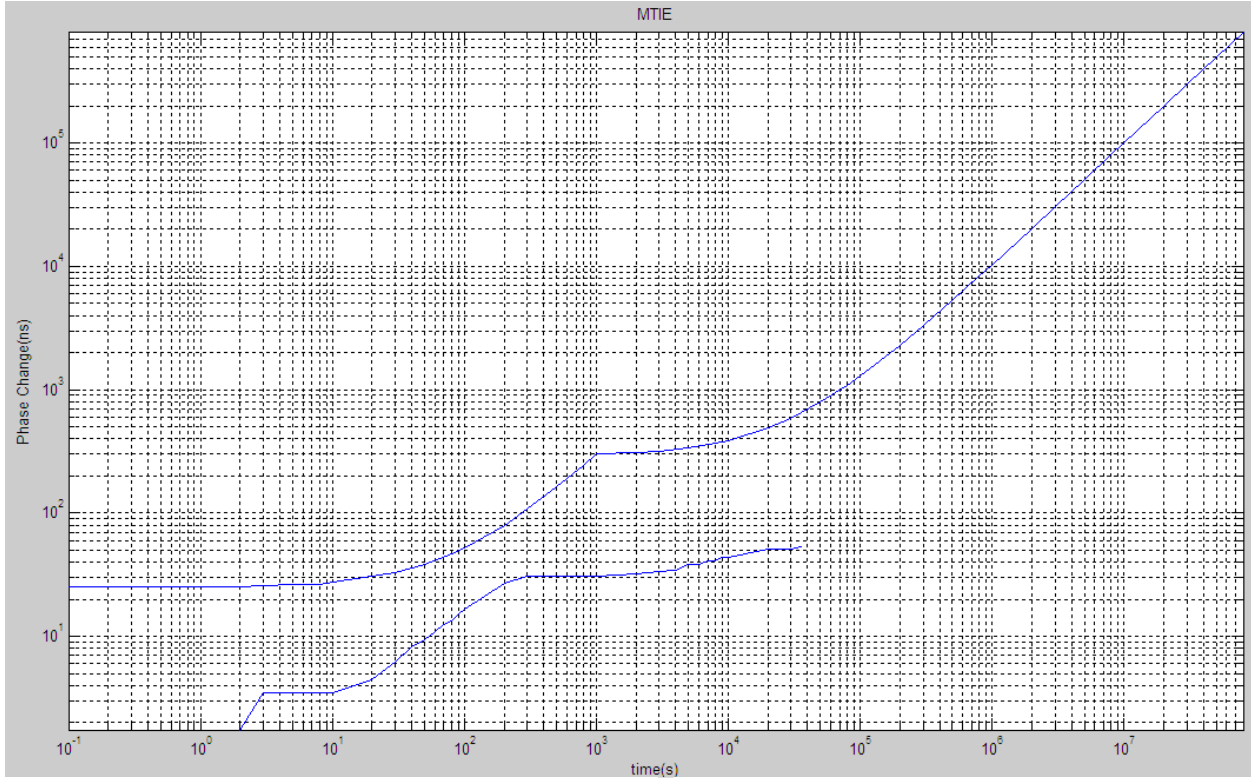



9. Mechanical Structure(mm)

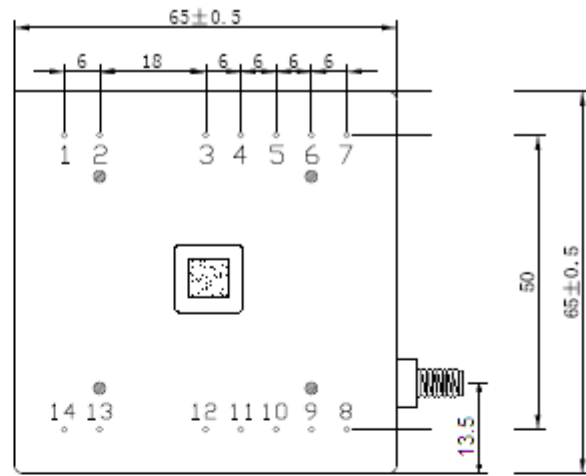

Bottom view

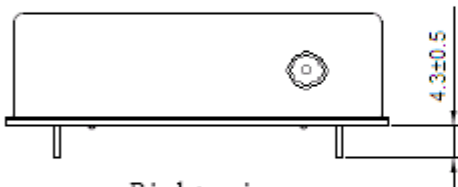

Right view

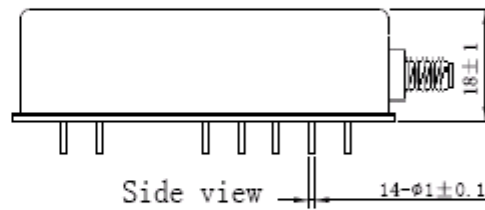

Side view



Top view

Note1: Tolerance $\pm 0.2\text{mm}$ without mark

Note2: Referential Weight $135\pm 10\text{g}$



PIN DEFINITION			
PIN	NAME	DESCRIPTION	
2	10MHz OUTPUT	10MHz OCXO frequency output .	
3	1PPS OUTPUT	The clock module 1PPS output .	
5	State OUTPUT	State output. Output high level means that the CM is locked and stable, others low level.	
6	RX INPUT	Asynchronous serial data input. 9600-N-8-1.	
7	TX OUTPUT	Asynchronous serial data output. 9600-N-8-1.	
8	State INPUT	H: Lock Enable	The work state is set to normal operation when the state input is high.
		L: Lock Disable	The module cannot be locked when the state input is low level.
10	GPS 1PPS OUTPUT	1PPS from the internal GPS receiver.	
12	VCC	Power supply input, 4.75V to 5.25V.	
1、 14	NC	Not connected.	
4、 9、 11、 13	GND	GND	



10.The Output Message Protocol

The output message contains two kind of protocol:

Default is NMEA message:

Send 24 50 AA 00 5A 00 03 output message is: DAPU custom message;

Send 24 50 AA 00 5A 00 12 output message is: NMEA message;

10.1 NMEA messages based on NMEA0183 Version 2.30. The following shows the structure.

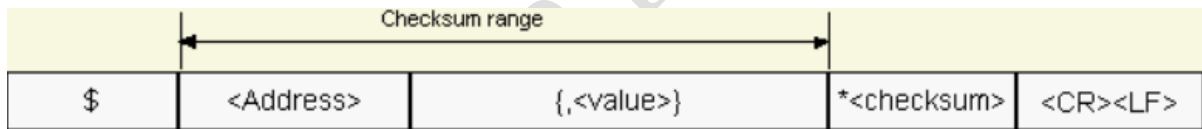
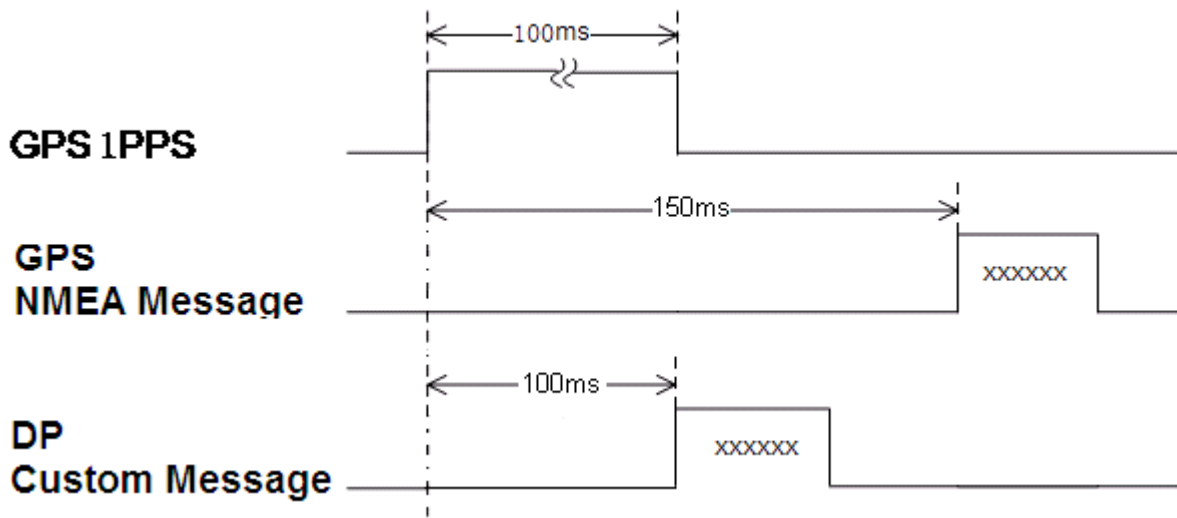

Field No.	Name	Format	Description	Length (byte)
0	\$	\$	Start character	1
1	Address Field	dd	Talker identifier, always GP for a GPS receiver, P for proprietary Messages	2
2	Address Field	ddd	Sentence formatter define the message content	3
3	Data field		Delimited by a ',' length can vary, even for a certain field.	
4	Checksum filed		Starts with a '*' and consists of 2 characters representing a hex number. The checksum is the exclusive OR of all characters between '\$' and '*'.	
5	End sequence		Always <CR><LF>	2



10.2 DAPU custom messages

In the Format column, c stand for char, d stand for digit, s stand for sign.

Field No.	Name	Format	Description	Length (byte)
0	\$PDP	\$ccc	Message ID, DAPU Telecom Technology protocol header	4
1	No	dd	Message No.	2
2	TxRxFlag	d	The transmit and receive flag.(0: upper computer transmit; 1: upper computer receive)	1
3	CStatus	c	Current status.(F: warm-up; L: Lock; H: Hold over)	1
4	TrackStatus	d	Track status (Q: fast track; S: slow track)	1
5	cPHDiff	sdddd	Current phase difference, 1 unit stand for 6.25ns	5
6	cPWM1	dddd.dddd	Current DAC1 (Voltage-controlled value1)	10
7	cPWM2	dddd.dddd	Current DAC 2 (Voltage-controlled value2), not used, output 32769.0000 as default.	10
8	SYNCNT	ddd	The synchronous times	3
9	HCNT	ddd	Power on hours count	3
10	HPAVG	dddd.dddd	The average of the DAC in the last half hour	10
11	VCH1	dddd.dddd	Voltage-controlled compensation value every half hour	10
12	HPMOD	dddd.dddd	The Module DAC Value	
13	VCM10	dddd.dddd	Voltage-controlled compensation value every 10 minutes	10
14	POS	d-dd	The position of the product.(Layer-No), just for the inner test.	4
15	TEMP	sddd.dddd	The temperature monitored inside the module	9
16	Alarm Flag	sdddd	The first 4 bytes are invalid, only the last 1 byte indicate Alarm flag(0: Normal; 1:OCXO heat up abnormal; 2:OCXO output abnormal; 3:The inside temperature sensor abnormal)	5
17	Website		www.dptel.com	13
18	Version	d.d	version	3
19	Date	dddd-dd-dd	Date	10
20		dd	65	2
21	END		<CR><LF>	2

The message output from Tx (PIN7), 9600 baud rate, data bits 8, stop bit 1, parity bit none, flow control bit none.



11.Coding Rules

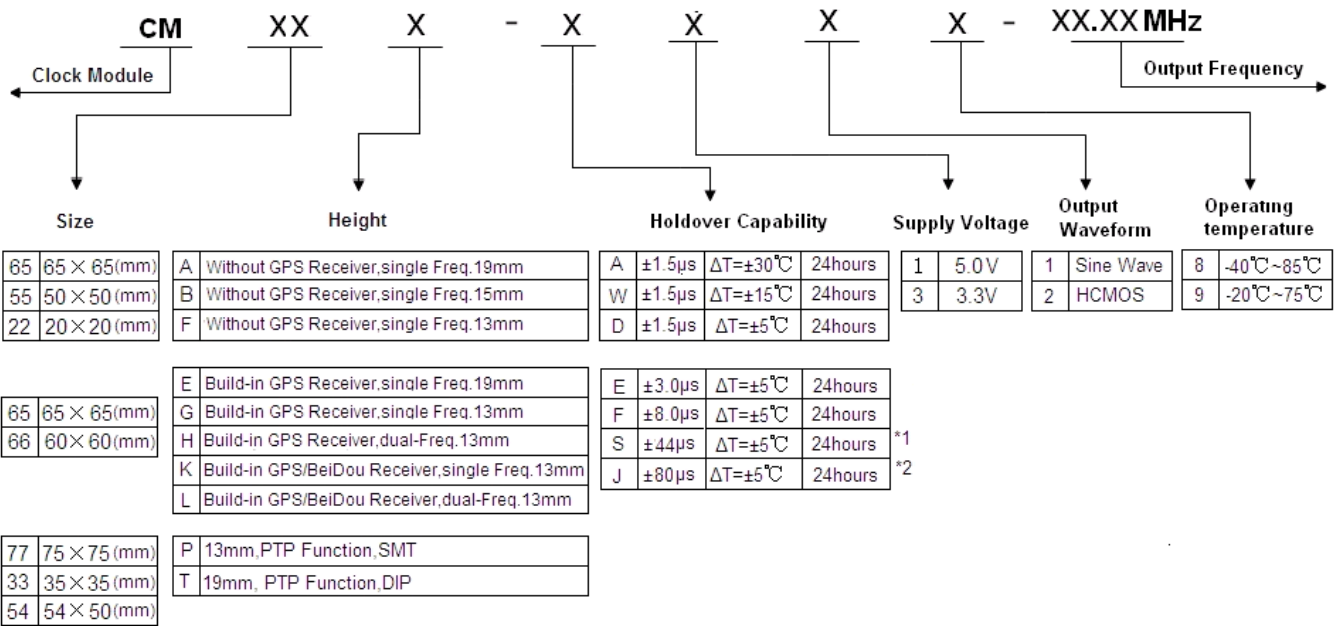

NOTE:*1 Power on and lock to the GPS 1PPS 2 hours
 *2 Power on and lock to the PTP 48 hours
 Default power on 7 days and lock to the reference source 3 days

12.Reflow Soldering Curve (RoHS)

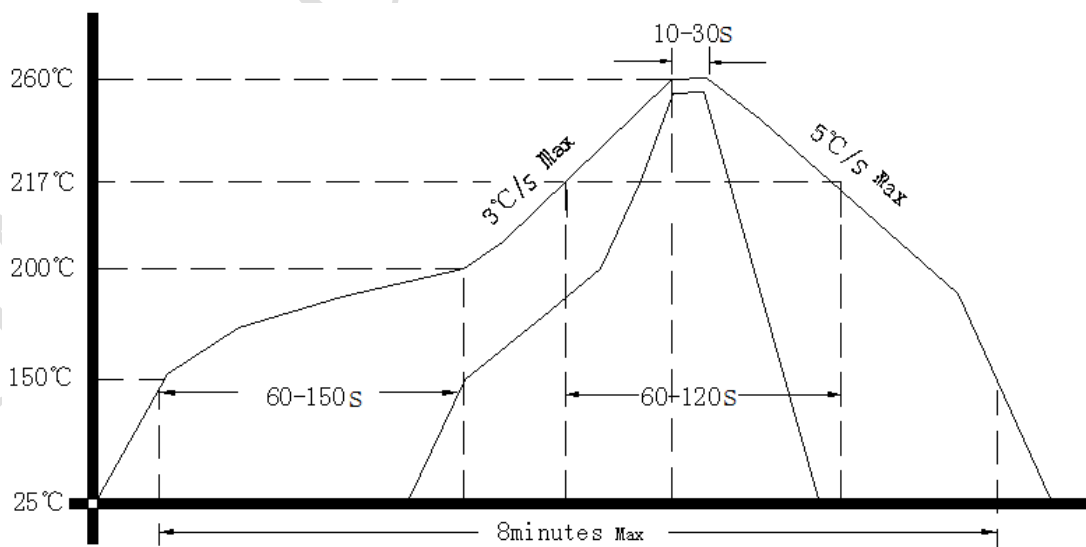



13.Package (mm)

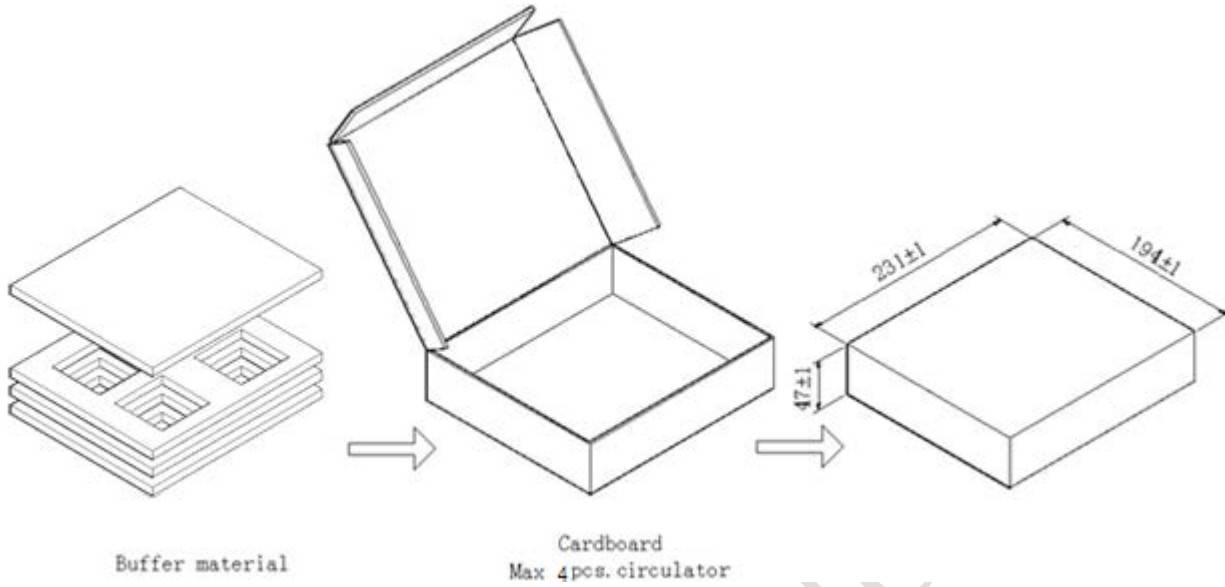

DAPU Confidential