



Table of amendment

Version	Revision contents	Prepared by	Revised date
1.0	The first issued	<i>Amway</i>	2016.11.17



1. Electrical Parameters

MODEL: O22S-1202-10.00MHz						
Item	Description	Parameters			Unit	Test Condition
		Min.	Typ.	Max.		
Output	Frequency	10.00			MHz	
	Output Waveform	LVCMOS				
	Output Low Voltage			0.4	V	$V_{cc}=3.3V, O_{load}=30pF$
	Output High Voltage	2.4			V	$V_{cc}=3.3V, O_{load}=30pF$
	Duty Cycle	45	50	55	%	@50%
	RF Output Current			4	mA	
	Rise/Fall Time (10%~90%)			5	ns	
	Load			30	pF	
	Start-up time			1.5	sec	@ -40°C~+85°C
	Alarm Output Current			1	mA	
	Oven alarm states and behavior:					
<ul style="list-style-type: none"> “1”: Oven normal operation: heating system is working properly and oven has warmed up. “0”: Oven is not ok: heating system is not working properly or oven warming-up. 						
Frequency Stabilities	Initial Frequency Tolerance	-10		+10	$\times 10^{-6}$	Measurement referenced to frequency observed with $T_A=25^\circ C$, $V_{cc}=3.3V$, and after 15 minutes of operation.
	Frequency Stability vs. Operating Temperature Range	-3		+3	$\times 10^{-9}$	T_A varied from $-40^\circ C \sim 85^\circ C$, measurement referenced to frequency observed with $f_{ref}=(f_{max}+f_{min})/2$, $V_{cc}=3.3V$, $O_{load}=30pF$, temperature variable more than $2^\circ C$ per minute, after 2 hours of operation, test time ≤ 2 hours.
	Frequency Stability Over Any $15^\circ C$ Of Ambient Temperature	-0.5		+0.5	$\times 10^{-9}$	T_A varied from $20^\circ C \sim 85^\circ C$, measurement referenced to frequency observed with $f_{ref}=(f_{max}+f_{min})/2$, $V_{cc}=3.3V$, $O_{load}=30pF$, temperature variable more than $0.5^\circ C$ per minute, after 2 days of operation.
		-0.8		+0.8	$\times 10^{-9}$	T_A varied from $-40^\circ C \sim 20^\circ C$, measurement referenced to frequency observed with $f_{ref}=(f_{max}+f_{min})/2$, $V_{cc}=3.3V$, $O_{load}=30pF$, temperature variable more than $0.5^\circ C$ per minute, after 2 days of operation.



	Frequency Stability Over Ambient Temperature	-0.3		+0.3	$\times 10^{-9}$	T_A varied from $80^\circ\text{C} \pm 5^\circ\text{C}$, measurement referenced to frequency observed with $f_{\text{ref}} = (f_{\text{max}} + f_{\text{min}}) / 2$, $V_{\text{cc}} = 3.3\text{V}$, $O_{\text{load}} = 30\text{pF}$, temperature variable more than 0.5°C per minute, after 2 days of operation.
	Frequency Stability vs. Supply Voltage	-0.1		+0.1	$\times 10^{-9}$	V_{cc} varied from 3.27V to 3.33V, and $O_{\text{Load}} = 30\text{pF}$.
	Overall tolerance over 15 years lifetime from 1h post-reflow frequency	-0.5		+0.5	$\times 10^{-6}$	after warm-up time including all frequency drift effects
	Frequency stability over any 20 min period	-5		+5	$\times 10^{-9}$	@ 25°C , after 20 minutes of operation
	Aging Tolerance Per Day	-0.05		+0.05	$\times 10^{-6}$	@ 25°C , after 5 min
		-3		+3	$\times 10^{-9}$	@ 25°C , after 24 hours
		-1		+1	$\times 10^{-9}$	@ 25°C , after 7 days
		-0.2		+0.2	$\times 10^{-9}$	@ 25°C , after 30 days
	Aging Tolerance 1 Month	-8		+8	$\times 10^{-9}$	@ 25°C , after 7 days
		-5		+5	$\times 10^{-9}$	@ 25°C , after 30 days
	Aging Tolerance 1 Years	-0.08		+0.08	$\times 10^{-6}$	@ 25°C , after 7 days
		-0.06		+0.06	$\times 10^{-6}$	@ 25°C , after 30 days
	G-sensitivity			3	$\times 10^{-9}/\text{G}$	
Warm Up Time	Frequency change during warm-up (after start-up time)			400	$\times 10^{-6}$	@ $-40^\circ\text{C} \sim +85^\circ\text{C}$ symmetric or asymmetric referred to 2h frequency (f_{2h})
	Warm-up @ -40°C			± 15	$\times 10^{-9}$	Tolerance between frequency tested after 7 min and 2h operation.
				± 150	$\times 10^{-9}$	Tolerance between frequency tested after 5 min and 2h operation.
	Warm-up @ -10°C			± 15	$\times 10^{-9}$	Tolerance between frequency tested after 6 min and 2h operation.
				± 150	$\times 10^{-9}$	Tolerance between frequency tested after 5 min and 2h operation.
	Warm-up @ $+25^\circ\text{C}$			± 15	$\times 10^{-9}$	Tolerance between frequency tested after 5 min and 2h operation.
				± 150	$\times 10^{-9}$	Tolerance between frequency tested after 4.25 min and 2h operation.
	Warm-up @ $+55^\circ\text{C}$			± 15	$\times 10^{-9}$	Tolerance between frequency tested after 4.5min and 2h operation.
				± 150	$\times 10^{-9}$	Tolerance between frequency tested after 4 min and 2h operation.



Retrace	Retrace Accuracy	-0.15		+0.15	$\times 10^{-6}$	@ -40°C~ +85°C, On 24h, Off 24h, On df after warm-up time
	Retrace time to $\leq \pm 5$ ppb			7	min	@ -40°C~ +85°C, On 1h, Off 15 min
	Retrace time to $\leq \pm 50$ ppb			5	min	@ 25°C, on 24h, off 1 week
	Retrace time to $\leq \pm 150$ ppb			45	s	@ -10°C ~ +85°C, off 10s
Power Supply	Supply Voltage	3.27	3.3	3.33	V	
	Steady Consumption			400	mA	@25°C
					700	mA
Warm up current			1200	mA	@ -40°C~ +85°C	
Phase Noise	Phase Noise @ -40 to 85°C			-70	dBc/Hz	1Hz
				-100		10Hz
				-125		100Hz
				-140		1KHz
				-145		10KHz
				-150		100KHz
Spurs And Harmonic	Accumulated Power Of Spurs And Harmonic Distortions @-40 to 85°C			-90	dBc	$10 \text{ Hz} \leq f_{\text{Offset}} < 300 \text{ Hz}$
				-90		$300 \text{ Hz} \leq f_{\text{Offset}} \leq 10 \text{ kHz}$
				-40		$10 \text{ kHz} \leq f_{\text{Offset}}$



Environmental Conditions	Operable Temperature	-40		+85	°C		
	Storage Temperature	-45		+90	°C		
	Rate Of Temperature Variation			2	°C/min		
	Relative Humidity Range	5		95	%		
	Absolute Humidity Range	1		29	g/m ³		
	Air pressure range	70		106	kPa		
	ESD Level	Human Body Model, class2: 2000V to 4000V; ANSI/ESDA/JEDEC JS-001-2010.					
		Machine Model, class B: 200V to 400V; ANSI/ESDA/JEDEC JS-001-2010.					
Moisture Sensitivity Level	Level 2.						
Vibration	Three-dimensional vibration, sinusoidal according to EN 300 019-2-4 Class 4M5 with amplitude modified by a gain of 10. <ul style="list-style-type: none"> • Amplitude of displacement: 12mm (5-9Hz) • Amplitude of acceleration: 40 m/ s2 (9-200Hz) 						
Full Package Storage	Relative humidity (%)	20%~70%					
	Temperature (°C)	-10~35°C					



2. Phase Stability In Holdover

Profile 1: Ramp with 0.5°C/min to max or min temperature at the beginning, constant for rest of time.

Profile 2: Continuous temperature cycling with 0.5°C/min between min and max temperatures.

Phase stability	Ambient temperature	Condition
6 sigma (99.99966%) all clauses	See below	After 7 days of continuous operation/ ageing Supply voltage stability $\pm 0.1\%$, load 15 pF
$\leq \pm 5 \mu\text{sec}$ over 4 h	+80°C $\pm 5^\circ\text{C}$ +80°C $\pm 5^\circ\text{C}$	Profile 1 Profile 2
$\leq \pm 10 \mu\text{sec}$ over 8 h	+80°C $\pm 3.5^\circ\text{C}$ +80°C $\pm 5^\circ\text{C}$	Profile 1 Profile 2

Phase stability	Ambient temperature	Condition
4 sigma (99.38%) all clauses	See below	After 7 days of continuous operation/ ageing Supply voltage stability $\pm 0.1\%$, load 15 pF
$\leq \pm 10 \mu\text{sec}$ over 12 h	+80°C $\pm 4^\circ\text{C}$ +80°C $\pm 5^\circ\text{C}$	Profile 1 Profile 2
$\leq \pm 10 \mu\text{sec}$ over 24 h	+80°C $\pm 0.5^\circ\text{C}$ +80°C $\pm 5^\circ\text{C}$	Profile 1 Profile 2
$\leq \pm 1.5 \mu\text{sec}$ over 4 h	+80°C $\pm 2^\circ\text{C}$ +80°C $\pm 5^\circ\text{C}$	Profile 1 Profile 2
$\leq \pm 1.5 \mu\text{sec}$ over 8 h	+80°C $\pm 0.5^\circ\text{C}$ +80°C $\pm 5^\circ\text{C}$	Profile 1 Profile 2



3. Mechanical Structure (mm)

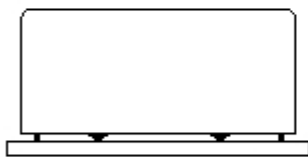
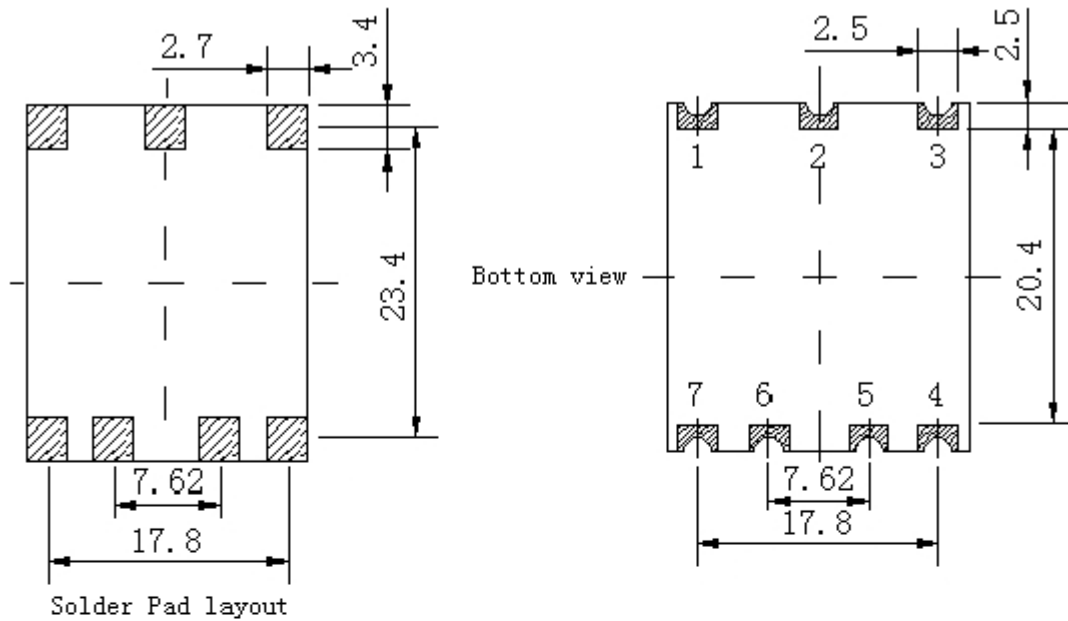

Side view



Right view

PIN FUNCTION

PIN	FUNCTION
1	Not Connect
2	Not Connect
3	Supply Voltage
4	RF Output
5	Oven Alarm
6	Not Connect
7	GND

Top view

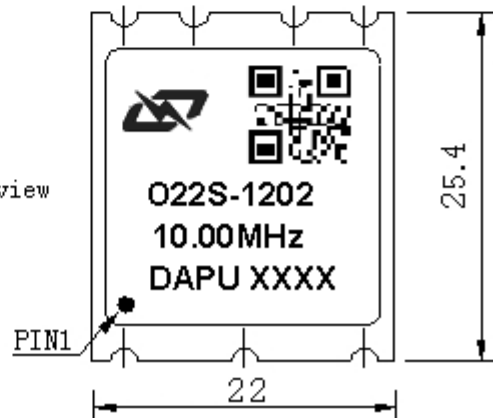

- Note1:** Tolerance ± 0.2 mm without mark
- Note2:** The first two xx representative: week
After two xx representative: year
- Note3:** Referential Weight <30g
- Note4:** NC is not connect



4. Test Circuit

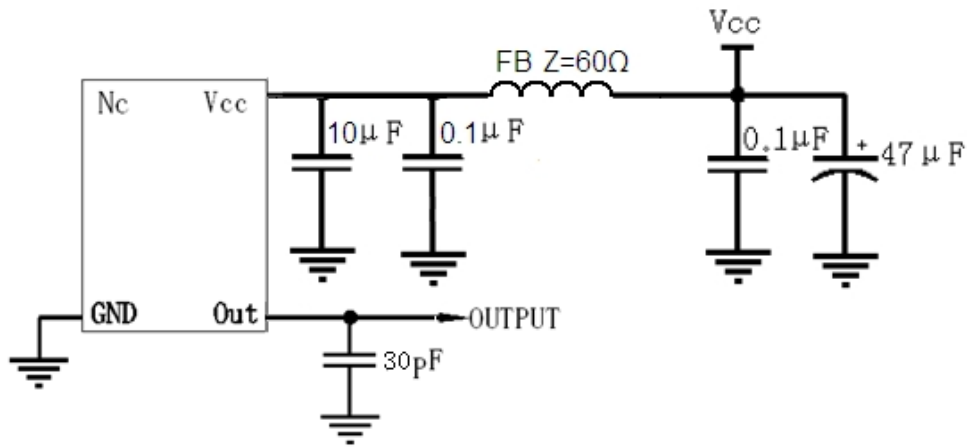

5. Reflow Soldering Curve (RoHS)

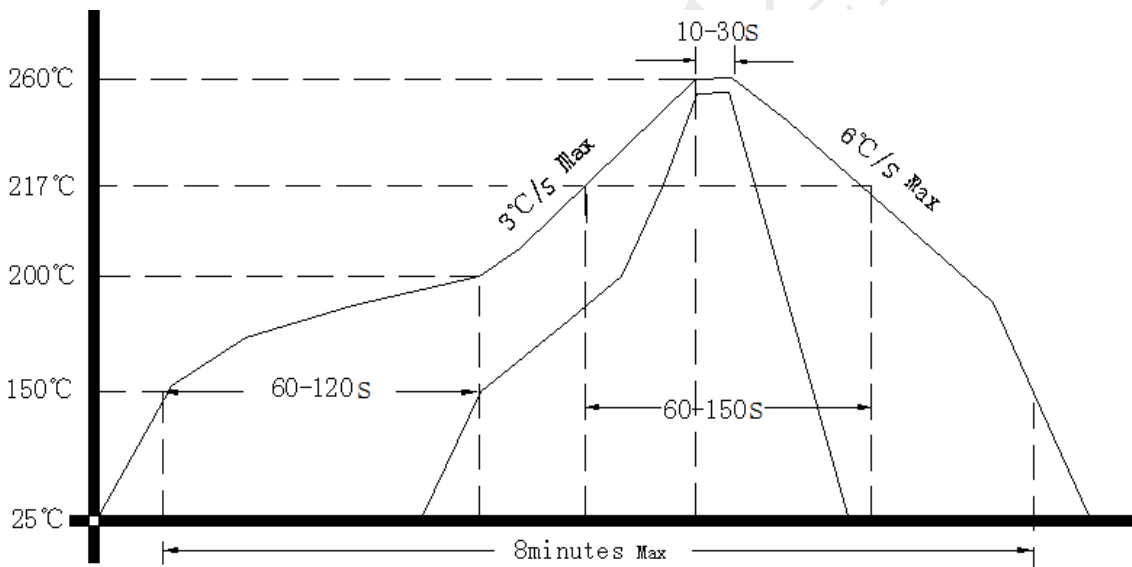

5. Package: Tape & Reel (mm)

