

Travelling Merchant: _____

DATASHEET

Standard: **V936-B615-491.52MHz**

P/N: _____

Plot			The Label
Drew	Audited	Approved	Stamp, please! Thanks!
Date: 2016.10.25			

Guangdong Dapu Telecom Technology Co.,Ltd

Bldg13-16,.N.Ind.Zone,SSL Industry Park, Dongguan City, Guangdong Province, China

TEL: 0086-0769-88010888 FAX: 0086-0769-81800098



1. Electrical Parameters

MODEL: V936-B615-491.52MHz						
Item	Description	Parameters			Unit	Test Condition
		Min.	Typ.	Max.		
Output	Frequency	491.52			MHz	
	Output Waveform	LVPECL				
	Output Low Voltage			V _{cc} -1.5	V	V _{cc} =3.3V, O _{load} =50Ω
	Output High Voltage	V _{cc} -1.1			V	V _{cc} =3.3V, O _{load} =50Ω
	Output Swing Level	0.6		1.6	V	
	Duty Cycle	40	50	60	%	@50%
	Rise / Fall Time (20%~80%)			1	ns	@25°C
	Load	50			Ω	
	Jitter		2.5		ps	RMS (12KHz ~20MHz)
	Start-up Time			10	ms	@25°C
	Sub harmonic suppression			-35	dBc	
Frequency Stabilities	Frequency Tolerance vs. Operating Temperature Range	-30		+30	× 10 ⁻⁶	T _A varied from -40°C to 85°C, measurement referenced to frequency observed with T _A =25°C, V _{cc} =3.3V, V _c =1.65V, O _{load} =50Ω, temperature variable speed less than 2°C per minute.
	Initial Frequency Tolerance	-20		+20	× 10 ⁻⁶	Measurement referenced to frequency observed with T _A =25°C, V _{cc} =3.3V, V _c =1.65V within 30 days after ex-works.
	Frequency Tolerance vs. Supply Voltage	-5		+5	× 10 ⁻⁶	measurement referenced to frequency observed T _A =25°C, V _{cc} varied from 2.97V to 3.63V, V _c =1.65V and O _{Load} =50Ω.
	Aging Tolerance 20 Year	-15		+15	× 10 ⁻⁶	T _A =25°C, V _{cc} =3.3V, V _c =1.65V and after 1h of operation.
	G-sensitivity			2	× 10 ⁻⁹ /G	Static acceleration [1/g], Test is done with X, Y and Z-axis, 1g=9.81m/s ² , Shaking frequency 5Hz – 500Hz
Power Supply	Current Consumption			65	mA	
	Supply Voltage	3.13	3.3	3.47	V	



Voltage Control Characteristics	Tuning sensitivity information	15		36	kHz/V	
	Linearity			10	%	
	Slope	Positive				
	Input Impedance	10			MΩ	
	Modulation Bandwidth	10			KHz	-3dB, V _c =1.65V
Phase Noise	Phase Noise		-59	-55	dBc/Hz	10Hz
			-94	-85		100Hz
			-117	-110		1KHz
			-136	-130		10KHz
			-148	-142		100KHz
Environmental Conditions	Operable Temperature	-40		+85	°C	
	Storage Temperature	-45		+90	°C	
	ESD Level	Human Body Model, class2: 2000V to 4000V; ANSI/ESDA/JEDEC JS-001-2010.				
		Machine Model, class B: 200V to 400V; ANSI/ESDA/JEDEC JS-001-2010.				
	Moisture Sensitivity Level	Level 2.				
	Vibration	Test Condition: 0.75mm; acceleration:10g;10Hz~2000Hz, one cycle per 30 min, test 2 hour. (3 times for each 3 directions X , Y , Z) .IEC 68-2-06 Test Fc.				
Shock	100g; 6ms; half sine wave (3 times for each 3 directions X , Y , Z),IEC 68-2-27 Test Ea/Severity 50A.					
Full Package Storage	Relative humidity (%)	20%~70%				
	Temperature (°C)	-10~35°C				



2. Mechanical Structure(mm)

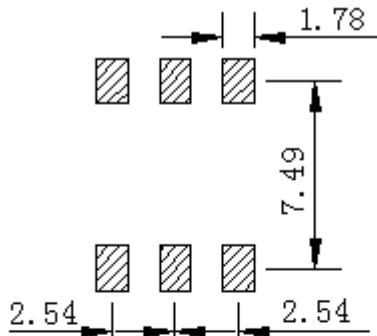

Solder pad layout

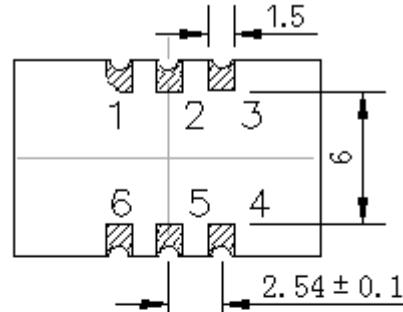

Bottom view

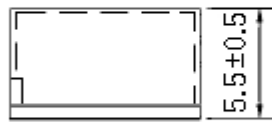

Right view

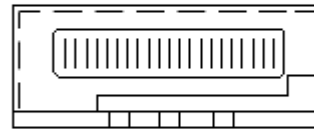

Front view

PIN FUNCTION

PIN	FUNCTION
1	VC
2	NC
3	GND
4	OUTPUT
5	OUTPUT
6	VCC

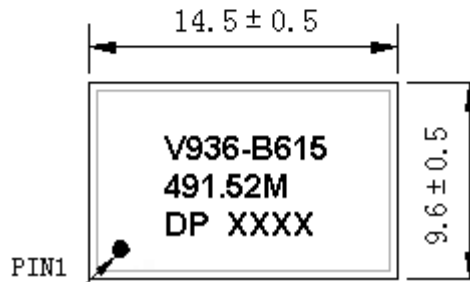

Top view

Note1: Tolerance $\pm 0.2\text{mm}$ without mark

Note2: Referential weight 1.4g

Note3: The first two xx representative: week
After two xx representative: year



3. Test circuit

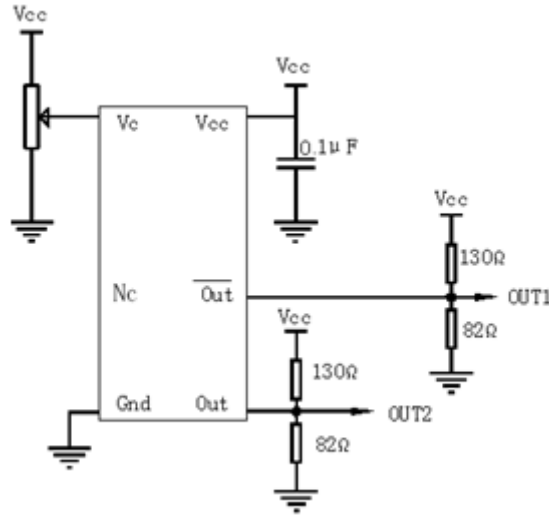

4. Reflow Soldering Curve (RoHS)

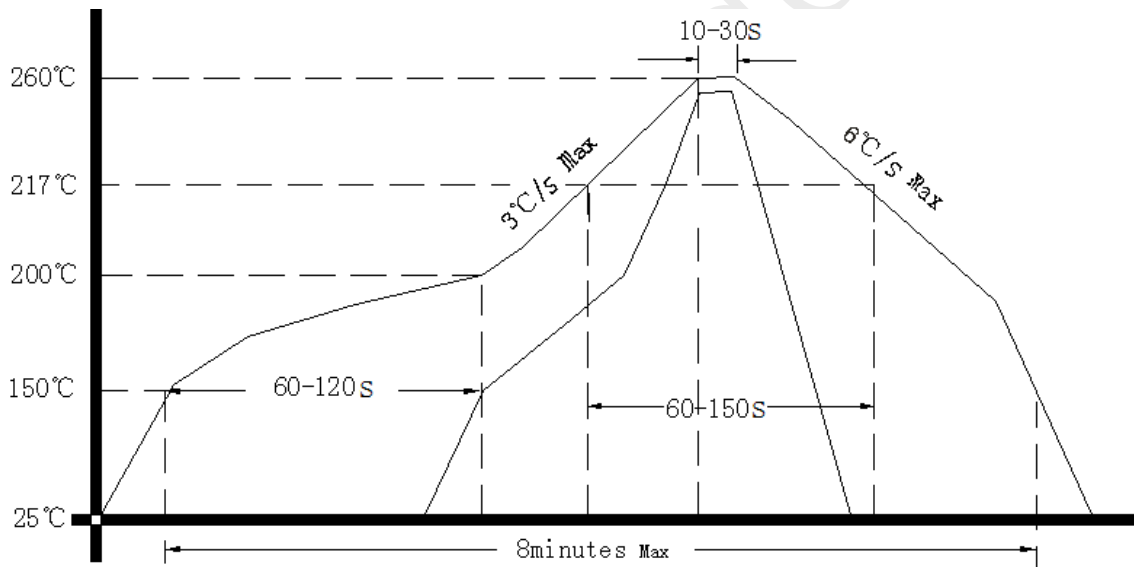

5. Package: Tape & Reel (mm)

