

Travelling Merchant: \_\_\_\_\_

# DATASHEET

Standard: DP7B20000003

Plot			The Label
Drew	Audited	Approved	Stamp, please! Thanks!
Date: 2016.08.25			

**Guangdong Dapu Telecom Technology Co.,Ltd**

Bldg13-16,.N.Ind.Zone,SSL Industry Park, Dongguan City, Guangdong Province, China

TEL: 0086-0769-88010888 FAX: 0086-0769-81800098



## 1、 Electrical Parameters

MODEL: DP7B2000003							
No.	Parameters	SYM.	Electrical Spec.				Notes
			Min.	Typ.	Max.	Units	
1	Nominal Frequency	FL	20.00			MHz	
2	Load Capacitance	CL	-	16	-	pF	
3	Frequency Tolerance	-	-20	-	+20	ppm	at 25°C
4	Frequency Stability	-	-30	-	+30	ppm	Over Operating Temp. Range (Reference 25°C)
5	Operating Temperature	-	-20	~	70	°C	
6	Drive Level	DL	-	100	-	uW	
7	Effective Series Resistance	ESR	-	-	40	Ω	
8	Shunt Capacitance C0	C0	-	-	5.0	pF	
9	DLD2	-	-	-	12	Ω	
10	RLD2	-	-	-	40	Ω	
11	ESD Level	Human Body Model,class2: 2000V to 4000V; ANSI/ESDA/JEDEC JS-001-2010.					
12		Machine Model, class B: 200V to 400V; ANSI/ESDA/JEDEC JS-001-2010.					
13	Moisture Sensitivity Level	Not humidity sensitive.					
14	Quality Level	Industrial					
15	Vibration	Test Condition: 0.75mm ;acceleration:10g;10Hz~2000Hz, one cycle per 30 min, test 2 hour. (3 times for each 3 directions X ,Y , Z) .IEC 68-2-06 Test Fc.					
16	Shock	100g; 6ms; half sine wave (3 times for each 3 directions X ,Y, Z ),IEC 68-2-27 Test Ea/Severity 50A.					



## 2、 Mechanical Structure(mm)

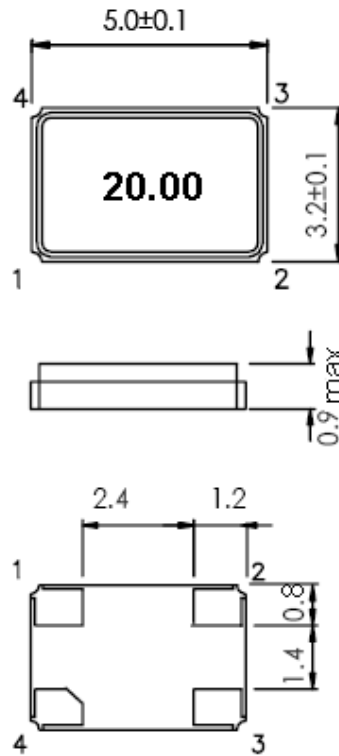

## 3、 Reflow Soldering Curve (RoHS)

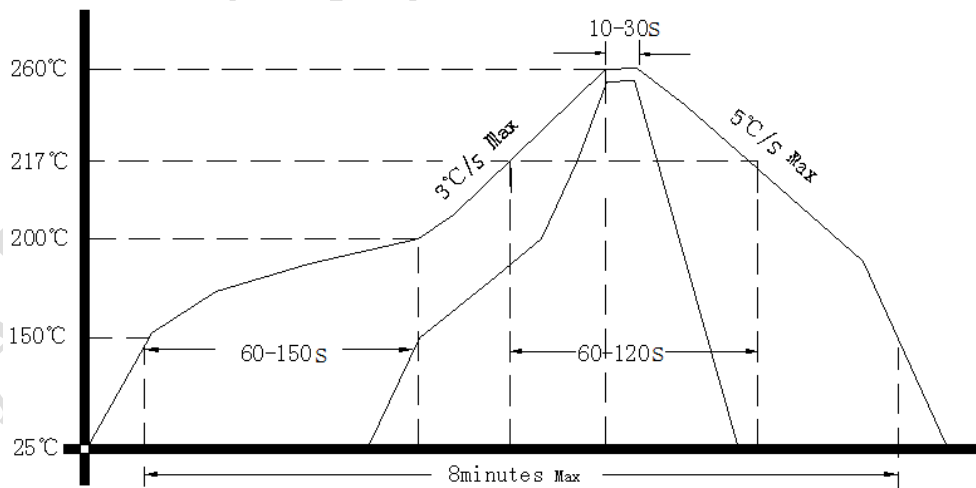



#### 4、 Package: Tape & Reel (mm)

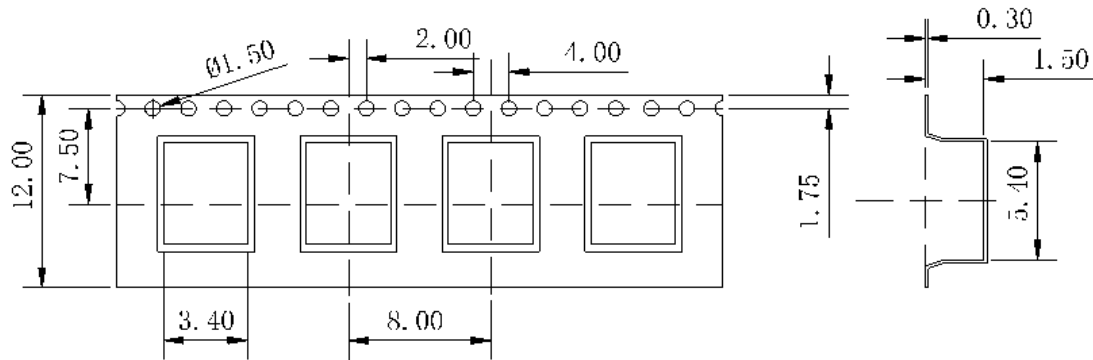

DAPU Confidential