



1. Electrical Parameters

MODEL: O22B-0801-10.00MHz						
Item	Description	Parameters			Unit	Test Condition
		Min.	Typ.	Max.		
Output	Frequency	10.00			MHz	
	Output Waveform	HCMOS				
	Output Low Voltage			0.3	V	$V_{cc}=5.0V, O_{load}=15pF$
	Output High Voltage	3.0			V	$V_{cc}=5.0V, O_{load}=15pF$
	Duty Cycle	45	50	55	%	@50%
	Rise / Fall Time (10%~90%)			6	ns	
	Load	15			pF	
	Jitter			1	ps	RMS (12kHz ~20MHz)
Frequency Stabilities	Frequency Tolerance vs. Operating Temperature Range	-0.01		+0.01	$\times 10^{-6}$	T_A varied from $-40^{\circ}C$ to $75^{\circ}C$, measurement referenced to frequency observed with $T_A=25^{\circ}C, V_{cc}=5.0V, V_c=2.5V, O_{load}=15 pF$, temperature rise speed less than $2^{\circ}C$ per minute.
		-0.02		+0.02	$\times 10^{-6}$	T_A varied from $75^{\circ}C$ to $85^{\circ}C$, measurement referenced to frequency observed with $T_A=25^{\circ}C, V_{cc}=5.0V, V_c=2.5V, O_{load}=15 pF$, temperature rise speed less than $2^{\circ}C$ per minute.
	Initial Frequency Tolerance	-0.2		+0.2	$\times 10^{-6}$	Measurement referenced to frequency observed with $T_A=25^{\circ}C, V_{cc}=5.0V, V_c=2.5V$, and after 15 minutes of operation, within 30 days after ex-works.
	Frequency Tolerance vs. Supply Voltage	-2		+2	$\times 10^{-9}$	measurement referenced to frequency observed $T_A=25^{\circ}C, V_{cc}$ varied from 4.75V to 5.25V, $V_c=2.5V$ and $O_{Load}=15pF$.
	Frequency Tolerance vs. Load	-2		+2	$\times 10^{-9}$	5% load change measurement referenced to frequency observed with $T_A=25^{\circ}C, V_{cc}=5.0V, V_c=2.5V$, and $O_{Load}=15pF$.
	Short-Term Stability: Allan Variance			0.03	$\times 10^{-9}$	Temperature stability, no EMI/EMC or other interference, test after power for 1hour ref. to $25^{\circ}C$; 1s, using PN9000 equipment.



	Aging Tolerance Per Day	-0.5		+0.5	$\times 10^{-9}$	V_{cc} , V_c , T_A constant measurement referenced to frequency observed with $T_A=25^\circ\text{C}$, $V_{cc}=5.0\text{V}$, $V_c=2.5\text{V}$, and after 30 days of operation.
	Aging Tolerance 1 Year	-0.1		+0.1	$\times 10^{-6}$	
	Aging Tolerance 10Year	-0.3		+0.3	$\times 10^{-6}$	
Power Supply	Supply Voltage	4.75	5.0	5.25	V	
	Steady Consumption			250	mA	@25°C
	Warm up current			800	mA	
	Warm-Up Time			5	minutes	@25°C within $\pm 0.01 \times 10^{-6}$ of final frequency with reference after 1 hour on.
Voltage Control Characteristics	Frequency Tuning Range	-2.4		-0.8	$\times 10^{-6}$	$V_c=0\text{V}$. measurement referenced to $V_c=2.5\text{V}$
		-0.2		+0.2	$\times 10^{-6}$	$V_c=2.5\text{V}$. measurement referenced to exactly 10.00MHz
		+0.8		+2.4	$\times 10^{-6}$	$V_c=5.0\text{V}$. measurement referenced to $V_c=2.5\text{V}$
	Linearity			10	%	
	Slope	Positive				
	Input Impedance	100			K Ω	
Phase Noise	Phase Noise		-120	-110	dBc/Hz	10Hz
			-140	-130		100Hz
			-150	-145		1KHz
			-155	-150		10KHz
			-155	-150		100KHz
			-155	-150		1MHz
			-155	-150		
Environmental Conditions	Operable Temperature	-40		+85	°C	
	Storage Temperature	-55		+105	°C	
	ESD Level	Human Body Model, class2: 2000V to 4000V; ANSI/ESDA/JEDEC JS-001-2010.				
		Machine Model, class B: 200V to 400V; ANSI/ESDA/JEDEC JS-001-2010.				
	Moisture Sensitivity Level	Not humidity sensitive.				
	Vibration	Test Condition: 0.75mm ;acceleration:10g;10Hz~500Hz, one cycle per 30 min, test 2 hour. (3 times for each 3 directions X , Y , Z), IEC 68-2-06 Test Fc.				
Shock	50g; 11ms; half sine wave (3 times for each 3 directions X, Y, Z), IEC 68-2-27 Test Ea/Severity 50A.					



2. Mechanical Structure (mm)

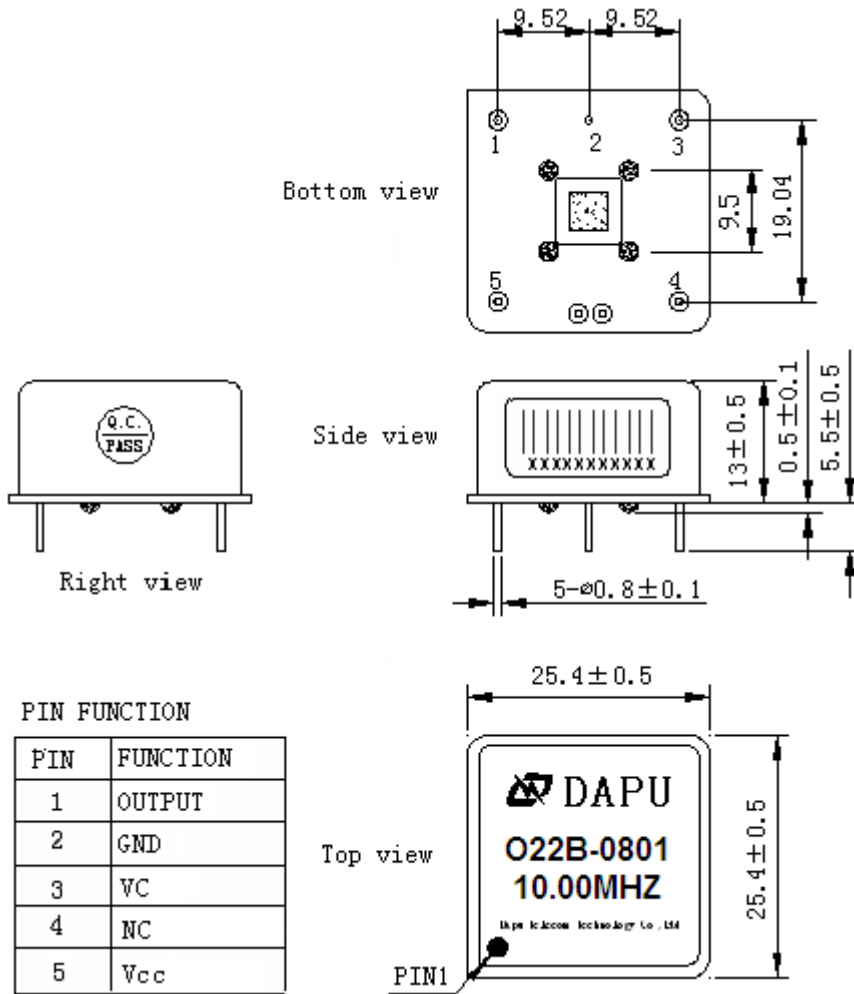

Note1: Tolerance ±0.2mm without mark

Note2: Referential Weight 13.6g

Note3: NC is not connect

3. Test Circuit

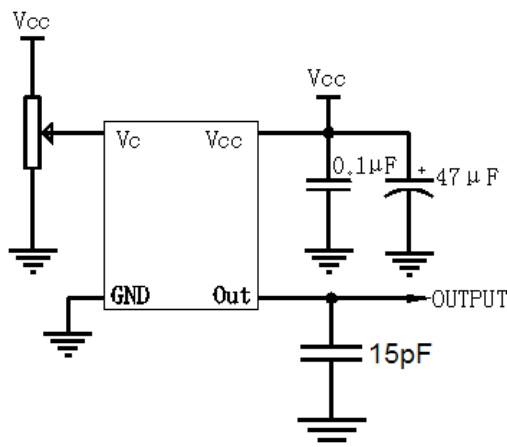



4. Reflow Soldering Curve (RoHS)



5. Package (mm)

