







## 1. Electrical Parameters

MODEL: O11F-1803-20.00MHz						
Item	Description	Parameters			Unit	Test Condition
		Min.	Typ.	Max.		
Output	Frequency	20.00			MHz	
	Output Waveform	LVCMOS				
	Output Low Voltage			0.4	V	$V_{cc}=3.3V, O_{load}=15pF$
	Output High Voltage	2.4			V	$V_{cc}=3.3V, O_{load}=15pF$
	Duty Cycle	45	50	55	%	@50%
	Rise / Fall Time (10%~90%)			6	ns	
	Load	15			pF	
	Warm up Time			5	mins	
	Start-up Time			100	ms	
Frequency Stabilities	Frequency Tolerance vs. Operating Temperature Range	-5		+5	$\times 10^{-9}$	$T_A$ varied from $-40$ to $85^\circ C$ , $V_{cc} = 3.3 V$ , and $O_{Load} = 15 pF$ . Measurement referenced to frequency observed With $T_A = 25^\circ C$ , $V_{cc} = 3.3V$ .
	Slope	-3		+3	$\times 10^{-9}/^\circ C$	$-40^\circ C$ to $85^\circ C$ , temperature ramp $1^\circ C/minute$
	Frequency Accuracy	-0.5		+0.5	$\times 10^{-6}$	Within 90 days after shipment and 15 minutes warm up time, Measurement referenced to exactly 20.00MHz.
	Initial Frequency Tolerance	-0.1		+0.1	$\times 10^{-6}$	After warm up 5 minute. Measurement referenced to frequency observed with $T_A = 25^\circ C$ , $V_{cc} = 3.3 V$ . and after 1 hour of operation.
	Frequency Tolerance vs. Supply Voltage	-2		+2	$\times 10^{-9}$	$T_A = 25^\circ C$ , $V_{cc}$ varied from 3.135 to 3.465 V, and $O_{Load} = 15 pF$ . Measurement referenced to frequency observed with $T_A = 25^\circ C$ , $V_{cc} = 3.3 V$ .
	Frequency Tolerance vs. Load	-1		+1	$\times 10^{-9}$	10% Load Change. Measurement referenced to frequency observed with $T_A = 25^\circ C$ , $V_{cc} = 3.3 V$ .
	Short-Term Stability: Allan Variance			0.05	$\times 10^{-9}$	Temperature stability, no EMI\EMC or other interference, test after power for 1hour ref. to $25^\circ C$ ; 1s, using PN9000 equipment.
			0.05	$\times 10^{-9}$	Temperature stability, no EMI\EMC or other interference, test after power for 1hour ref. to $25^\circ C$ ; 100s, using PN9000 equipment.	



	Aging Tolerance Per Day	-2		+2	$\times 10^{-9}$	$V_{cc}$ , $T_A$ constant. Measurement referenced to frequency observed with $T_A=25^\circ\text{C}$ , $V_{cc}=3.3\text{V}$ . and after 30 days of operation
	Aging Tolerance 1 Year	-0.5		+0.5	$\times 10^{-6}$	
	Aging Tolerance 10 Years	-3		+3	$\times 10^{-6}$	
Power Supply	Supply Voltage	3.135	3.3	3.465	V	
	Steady Consumption			300	mA	@25°C
	Warm up current			700	mA	
Phase Noise	Phase Noise @25°C			-65	dBc/Hz	1Hz
				-95		10Hz
				-120		100Hz
				-140		1KHz
				-145		10KHz
				-152		100KHz
				-152		1MHz
				-152		5MHz
Environmental Conditions	Operable Temperature	-40		+85	°C	
	Storage Temperature	-55		+105	°C	
	ESD Level	Human Body Model, class2: 2000V to 4000V; ANSI/ESDA/JEDEC JS-001-2010.				
		Machine Model, class B: 200V to 400V; ANSI/ESDA/JEDEC JS-001-2010.				
	Moisture Sensitivity Level	Level 2.				
	Vibration	Test Condition: 0.75mm ;acceleration:10g;10Hz~500Hz, one cycle per 30 min, test 2 hour. (3 times for each 3 directions X , Y , Z), IEC 68-2-06 Test Fc.				
Shock	50g; 11ms; half sine wave (3 times for each 3 directions X, Y, Z), IEC 68-2-27 Test Ea/Severity 50A.					
Full Package Storage	Relative humidity (%)	20%~70%				
	Temperature (°C)	-10~35°C				



## 2. Mechanical Structure (mm)

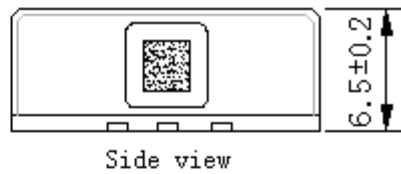
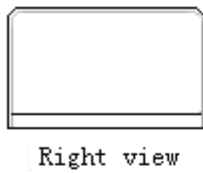
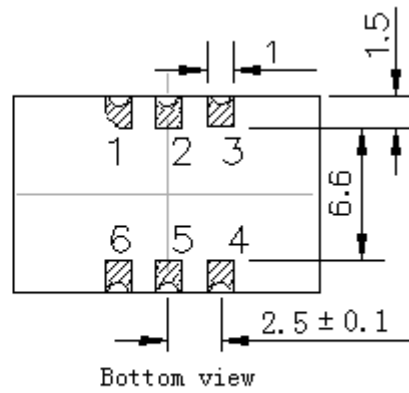
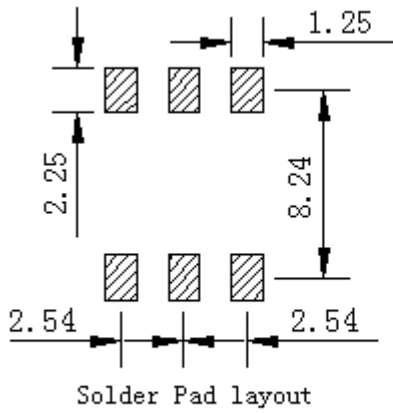

### PIN FUNCTION

PIN	NOTATION	FUNCTION
1	NC	Not Connect
2,5	NC	Not Connect
3	GND	GND
4	OUTPUT	RF Output
6	VCC	Supply Voltage

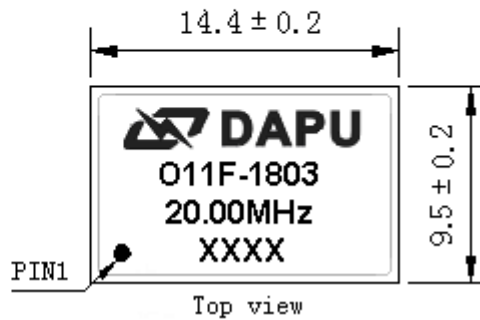

- Note1:** Tolerance  $\pm 0.20\text{mm}$  without mark
- Note2:** The first two xx representative: week  
After two xx representative: year
- Note3:** Referential Weight 1.5g
- Note4:** NC is not connect



### 3. Test Circuit

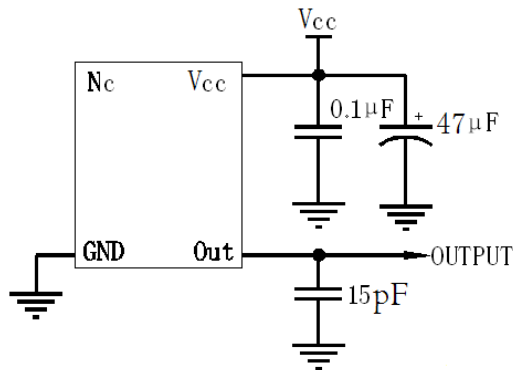

### 4. Reflow Soldering Curve (RoHS)

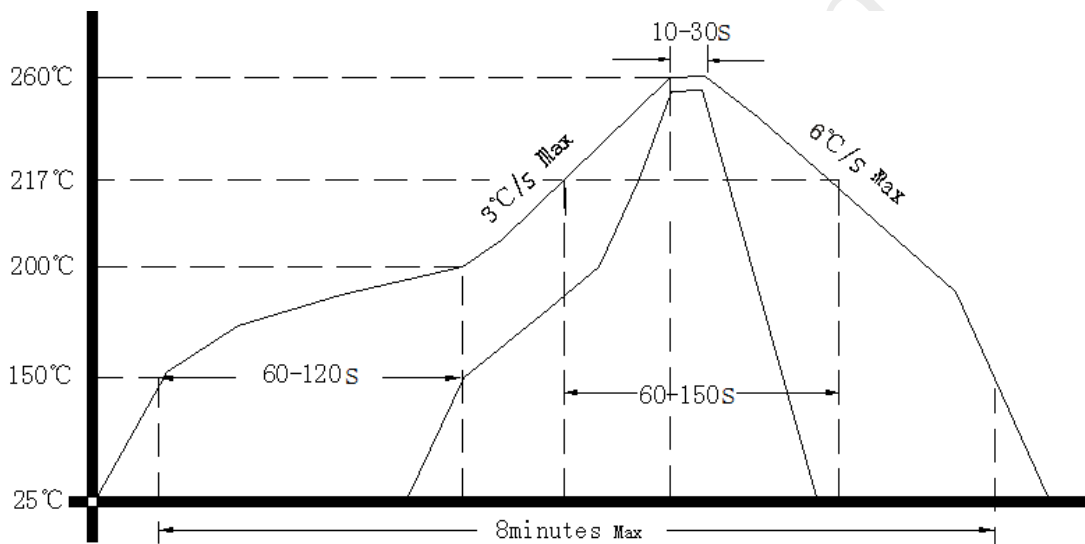

### 5. Package: Tape & Reel (mm)

