

Customer Code : _____

DATASHEET

DAPU P/N: **V756-A719-200.00MHz**

Customer P/N: _____

DAPU			Customer Approval
Drew	Audited	Approved	Stamp, please! Thanks!
Date: 2016.05.16			

Guangdong Dapu Telecom Technology Co.,Ltd

Bldg 16,.N.Ind.Zone,SSL Industry Park, Dongguan City, Guangdong Province, China

TEL: 0086-0769-88010888 FAX: 0086-0769-81800098



1、 Electrical Parameters

Parameters	SYM	Electrical Spec.				Notes
		Min.	Typ.	Max.	Units	
Nominal Frequency	F _N	200.00			MHz	
Frequency Stability	F _{STAB}	-25		+85	× 10 ⁻⁶	Inclusive of initial tolerance, operating temperature, rated power supply voltage, and load variations @25°C
Vs. aging /1.year		-2		+2	× 10 ⁻⁶	
Vs. aging /10 years		-5		+5	× 10 ⁻⁶	
Output Waveform		LVDS				
Load	I _{OUT}	100			Ω	
Input Voltage High	V _{OH}	0.7V _{CC}			V	
Input Voltage Low	V _{OL}			0.3V _{CC}	V	
Rise / Fall Time	T _r /T _f		495	600	ps	10%-90%
Symmetry	SYM	45	~	55	%	@50%
Start-up Time	T _S		6	10	ms	
Supply Voltage	V _{CC}	2.25	2.5	2.75	V	
Input Current	I _{CC}		XX		mA	
Input Impedance	Z _{IN}		100	250	MΩ	Pin 1,OE logic high or logic low
Current consumption	I _{dd}		47	55	mA	Excluding Load Termination Current, V _{dd} =3.3V or 2.5V
OE Disable Supply Current	I-OE			35	mA	OE=Low
Different Output Voltage	VOD	250	350	450	mA	
Output Disable Leakage Current	I-leak			1	uA	OE=Low
Standby Current	I-std			100	uA	
VOD Magnitude Change	ΔVOD			50	mV	
Offset Voltage	VOS	1.125	1.2	1.375	V	
VOS Magnitude Change	ΔVOS			50	mV	
Rise/Fall Time	Tr,Tf		498	600	ps	20%-80%
OE Enable /Disable Time	T-oe			115	ns	T-oe=100ns+3period
RMS Period Jitter	T-jitt		1.2	1.7	ps	V _{CC} = 2.5V



Environmental Conditions	
Temperature Cycle	JESD22,Method A104
Solderability	MIL-STD-883F, Method 2003
Moisture Sensitivity Level	MSL1 @260°C.
Mechanical Vibration	MIL-STD-883F,Method 2007
Mechanical Shock	MIL-STD-883F,Method 2002

2、 Mechanical Structure(mm)

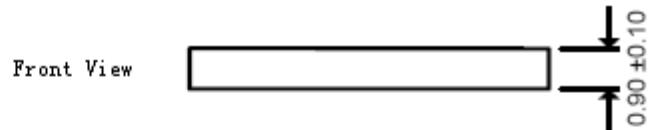
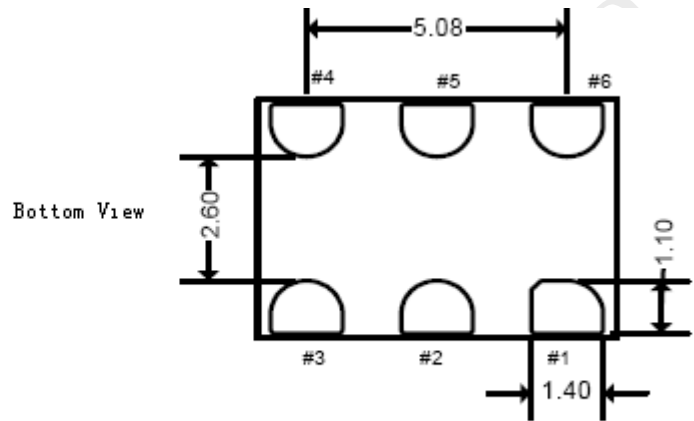
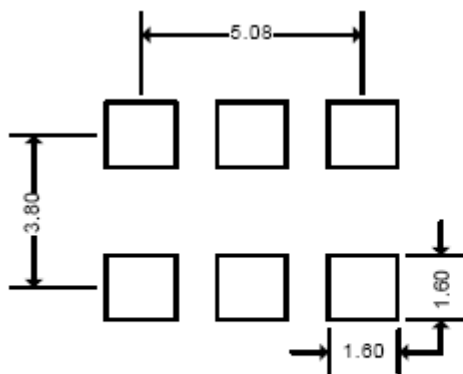

PIN FUNCTION

PIN	NOTATION	FUNCTION
1	OE	Output Enable
2	NC	Not Connect
3	GND	GND
4	OUTPUT	RF Output
5	$\overline{\text{OUTPUT}}$	RF Output Complementary
6	VCC	Supply Voltage

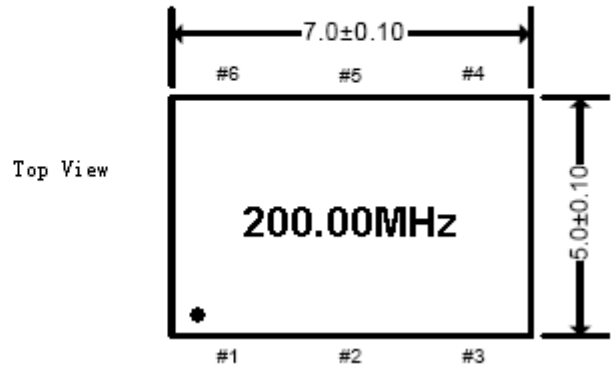

Note1: Tolerance $\pm 0.1\text{mm}$ without mark

Note2: Referential Weight 0.3g



3、 Test circuit

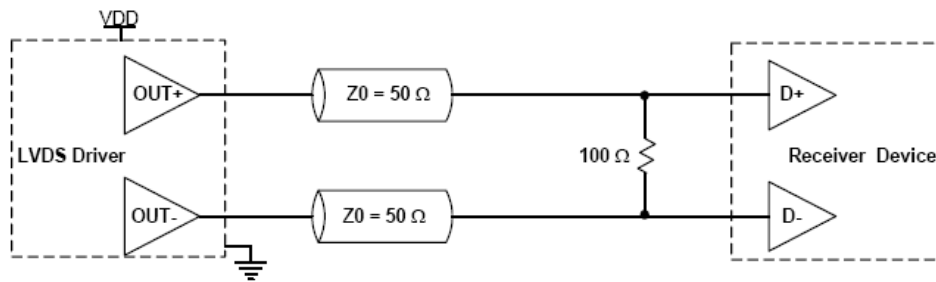

4、 Package: Tape & Reel (mm)

