

Customer Code: _____

DATASHEET

DAPU P/N: DP7C24576001

Y53NNM24576

DAPU			Customer Approval
Drew	Audited	Approved	Stamp, please! Thanks!
Date: 2015.12.16			

Guangdong Dapu Telecom Technology Co.,Ltd

Bldg16,.N.Ind.Zone,SSL Industry Park, Dongguan City, Guangdong Province, China

TEL: 0086-0769-88010888 FAX: 0086-0769-81800098



1、Electrical Parameters

MODEL: DP7C24576001							
No.	Parameters	SYM.	Electrical Spec.				Notes
			Min.	Typ.	Max.	Units	
1	Nominal Frequency	FL	24.576			MHz	
2	Output Waveform		HCMOS				
3	Frequency Tolerance	-	-30		+30	$\times 10^{-6}$	at 25°C $\pm 3^\circ\text{C}$
4	Frequency Temperature Stability	-	-30		+30	$\times 10^{-6}$	Over Operating Temp. Range (Reference 25°C)
5	Operating Temperature	Topr	-20	~	+70	°C	
6	Storage Temperature	Tstg	-40	~	+85	°C	
7	Supply Voltage	VDD	3.3 \pm 10%			V	
8	Output Symmetry	-	45	~	55	%	
9	Output Load:	CL	15			pF	
10	Aging	-	-3	-	+3	$\times 10^{-6}/\text{yr}$.	1st. Year at 25°C
11	Rise Time	Tr	-	-	5	ns	10%-90% VDD Level
12	Fall Time	Tf	-	-	5	ns	90%-10% VDD Level
13	ESD Level	Human Body Model,class2: 2000V to 4000V; ANSI/ESDA/JEDEC JS-001-2010.					
		Machine Model, class B: 200V to 400V; ANSI/ESDA/JEDEC JS-001-2010.					
14	Moisture Sensitivity Level	Level 2.					
15	Vibration	Test Condition: 0.75mm ;acceleration:10g;10Hz~2000Hz, one cycle per 30 min, test 2 hour. (3 times for each 3 directions X ,Y , Z) .IEC 68-2-06 Test Fc.					
16	Shock	100g; 6ms; half sine wave (3 times for each 3 directions X ,Y , Z),IEC 68-2-27 Test Ea/Severity 50A.					
17	Full Package Storage	Relative humidity (%)		20% ~70%			
		Temperature (°C)		-10~35°C			



2、Mechanical Structure(mm)

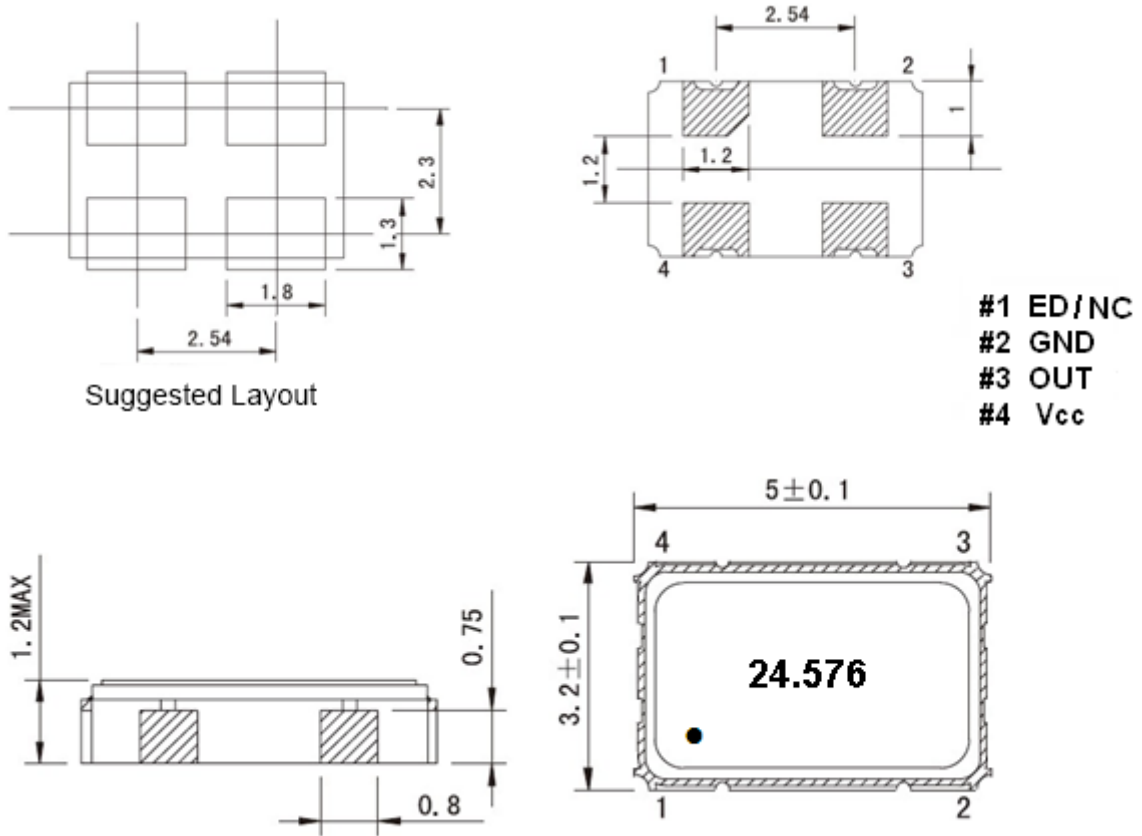

Note1: Tolerance ± 0.2 mm without mark

3、Test circuit

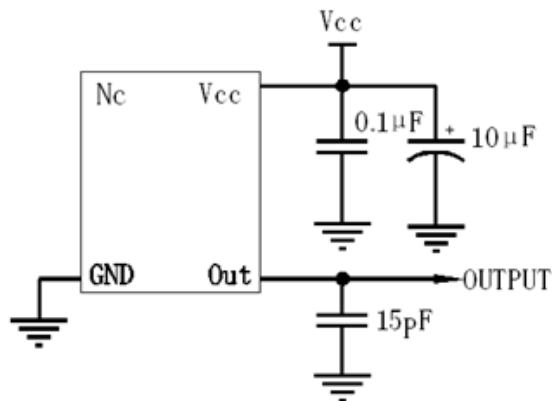



4、 Reflow Soldering Curve (RoHS)

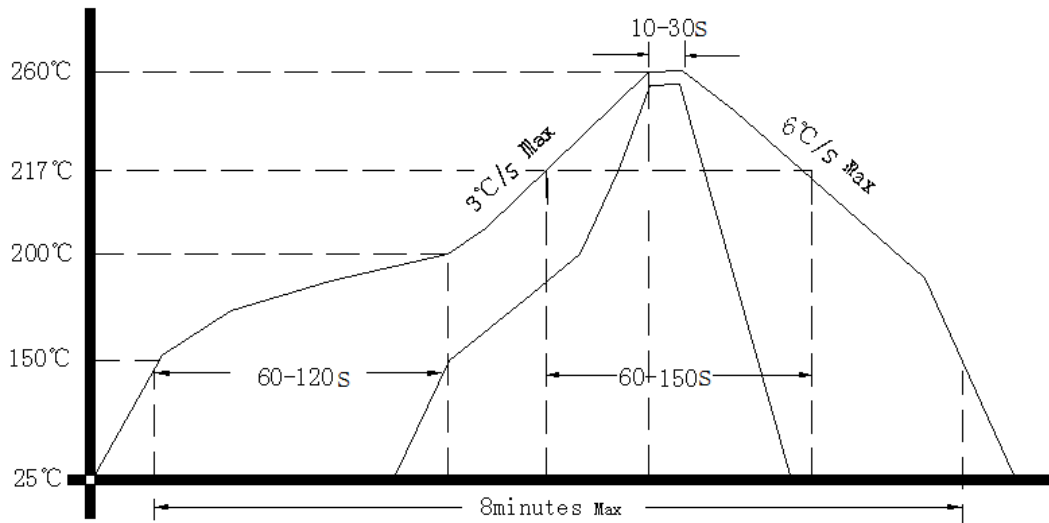

5、 Package: Tape & Reel (mm)

