

Customer Code : \_\_\_\_\_

# DATASHEET

DAPU P/N: O23B-Q426-100.00MHz-A

Customer P/N: \_\_\_\_\_

| DAPU             |         |          | Customer Approval      |
|------------------|---------|----------|------------------------|
| Drew             | Audited | Approved | Stamp, please! Thanks! |
|                  |         |          |                        |
| Date: 2016.04.20 |         |          |                        |

## Guangdong Dapu Telecom Technology Co.,Ltd

Bldg 16,.N.Ind.Zone,SSL Industry Park, Dongguan City, Guangdong Province, China

TEL: 0086-0769-88010888 FAX: 0086-0769-81800098





## 1. Electrical Parameters

| MODEL: O23B-Q426-100.00MHZ-A |   |            |      |       |                  |  |
|------------------------------|---|------------|------|-------|------------------|--|
| Item                         | Description   | Parameters |      |       | Unit             | Test Condition   |
|                              |   | Min.       | Typ. | Max.  |                  |  |
| Output                       | Frequency   | 100.00     |      |       | MHz              |  |
|                              | Output Waveform                                     | Sine wave  |      |       |                  |  |
|                              | Level   | 8          | 13   |       | dBm              |  |
|                              | Load  | 50         |      |       | $\Omega$         |  |
|                              | Harmonics Suppression                               |            |      | -50   | dBc              |  |
|                              | Spurious Suppression                                |            |      | -80   | dBc              |  |
| Frequency Stabilities        | Frequency Tolerance vs. Operating Temperature Range | -0.05      |      | +0.05 | $\times 10^{-6}$ | $T_A$ varied from $-40^\circ\text{C}$ to $85^\circ\text{C}$ , measurement referenced to frequency observed with $f_{\text{ref}}=(f_{\text{max}}+f_{\text{min}})/2$ , $V_{\text{cc}}=5.0\text{V}$ , $V_c=2.5\text{V}$ , $O_{\text{load}}=50\Omega$ , temperature variable speed less than $2^\circ\text{C}$ per minute. |
|                              | Initial Frequency Tolerance                         | -0.1       |      | +0.1  | $\times 10^{-6}$ | Measurement referenced to frequency observed with $T_A=25^\circ\text{C}$ , $V_{\text{cc}}=5.0\text{V}$ , $V_c=2.5\text{V}$ and after 15 minutes of operation, within 30 days after ex-works.   |
|                              | Frequency Tolerance vs. supply voltage              | -5         |      | +5    | $\times 10^{-9}$ | measurement referenced to frequency observed $T_A=25^\circ\text{C}$ , $V_{\text{cc}}$ varied from 4.75V to 5.25V, $V_c=2.5\text{V}$ , $O_{\text{load}}=50\Omega$ .   |
|                              | Frequency Tolerance vs. Load                        | -5         |      | +5    | $\times 10^{-9}$ | 5% Load Change Measurement referenced to frequency observed with $T_A=25^\circ\text{C}$ , $V_{\text{cc}}=5.0\text{V}$ , $V_c=2.5\text{V}$ , $O_{\text{load}}=50\Omega$ .   |
|                              | Short Term Stability                                |            |      | 0.01  | $\times 10^{-9}$ | Temperature stability, no EMI\EMC or other interference, test after power for 1hour ref. to $25^\circ\text{C}$ ; 1s, using PN9000 equipment.   |
|                              | Aging Tolerance per day                             | -1         |      | +1    | $\times 10^{-9}$ | $V_{\text{cc}}, V_c, T_A$ constant Measurement referenced to frequency observed with $T_A=25^\circ\text{C}$ , $V_{\text{cc}}=5.0\text{V}$ , $V_c=2.5\text{V}$ , $O_{\text{load}}=50\Omega$ and after 30 days of operation.   |
|                              | Aging Tolerance 1Year                               | -0.1       |      | +0.1  | $\times 10^{-6}$ |  |
| Power Supply                 | Supply Voltage                                      | 4.75       | 5.0  | 5.25  | V                |  |
|                              | Steady Consumption                                  |            |      | 400   | mA               | @ $25^\circ\text{C}$   |
|                              | Warm up current                                     |            |      | 900   | mA               |  |
|                              | Warm-Up Time  |            |      | 5     | min              | @ $25^\circ\text{C}$ within $\pm 0.1 \times 10^{-6}$ of final frequency with reference after 1 hour on.  |



|                                 |  |  |      |      |                  |   |
|---------------------------------|--|--|------|------|------------------|---|
| Voltage Control Characteristics | Frequency Tuning Range   |  |      | -0.5 | $\times 10^{-6}$ | $V_c=0V$ . measurement referenced to $V_c=2.5V$ .         |
|                                 |  | -0.1   |      | +0.1 | $\times 10^{-6}$ | $V_c=2.5V$ . measurement referenced to exactly 100.00MHz. |
|                                 |  | +0.5   |      |      | $\times 10^{-6}$ | $V_c=5.0V$ . measurement referenced to $V_c=2.5V$ .       |
|                                 | Linearity  |  |      | 10   | %                |   |
|                                 | Slope  | Positive   |      |      |                  |   |
|                                 | Input Impedance  | 100  |      |      |                  | K $\Omega$  |
| Phase Noise                     | Phase Noise @25 $^{\circ}C$  |  | -110 | -105 | dBc/Hz           | 10Hz  |
|                                 |  |  | -140 | -135 |                  | 100Hz   |
|                                 |  |  | -165 | -160 |                  | 1KHz  |
|                                 |  |  | -176 | -172 |                  | 10KHz   |
|                                 |  |  | -180 | -178 |                  | 100KHz  |
|                                 |  |  |      |      |                  |   |
| Environmental Conditions        | Operable Temperature   | -40  |      | +85  | $^{\circ}C$      |   |
|                                 | Storage Temperature  | -55  |      | +105 | $^{\circ}C$      |   |
|                                 | ESD Level  | Human Body Model, class2: 2000V to 4000V; ANSI/ESDA/JEDEC JS-001-2010.   |      |      |                  |   |
|                                 |  | Machine Model, class B: 200V to 400V; ANSI/ESDA/JEDEC JS-001-2010.   |      |      |                  |   |
|                                 | Moisture Sensitivity Level   | Not humidity sensitive.  |      |      |                  |   |
|                                 | Vibration  | Test Condition: 0.75mm ;acceleration:10g;10Hz~500Hz, one cycle per 30 min, test 2 hour. (3 times for each 3 directions X ,Y , Z), IEC 68-2-06 Test Fc. |      |      |                  |   |
| Shock                           | 50g; 11ms; half sine wave (3 times for each 3 directions X ,Y, Z ),IEC 68-2-27 Test Ea/Severity 50A. |  |      |      |                  |   |
| Full Package Storage            | Relative humidity (%)  | 20%~70%  |      |      |                  |   |
|                                 | Temperature ( $^{\circ}C$ )  | -10~35 $^{\circ}C$   |      |      |                  |   |



## 2. Mechanical Structure (mm)

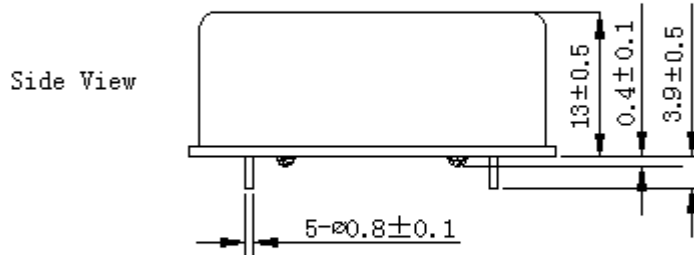
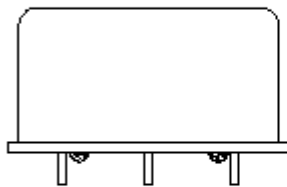
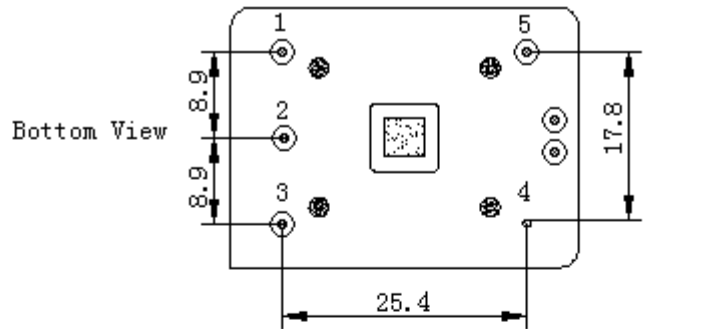

### PIN FUNCTION

| PIN | NOTATION | FUNCTION        |
|-----|----------|-----------------|
| 1   | WCC      | Supply Voltage  |
| 2   | NC       | Not Connect     |
| 3   | VC       | Control Voltage |
| 4   | GND      | GND             |
| 5   | OUTPUT   | RF Output       |

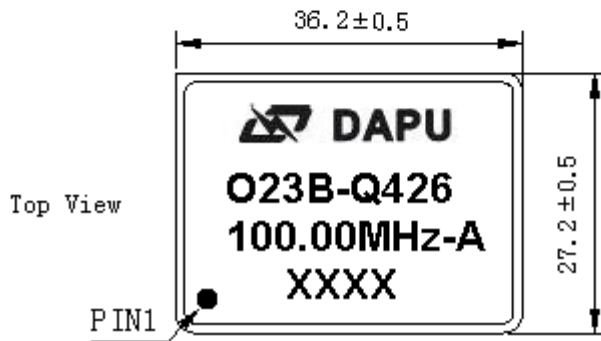

- Note1:** Tolerance  $\pm 0.20\text{mm}$  without mark
- Note2:** The first two xx representative: week  
After two xx representative: year
- Note3:** Referential Weight 20.7g
- Note4:** NC is not connect



### 3. Test Circuit

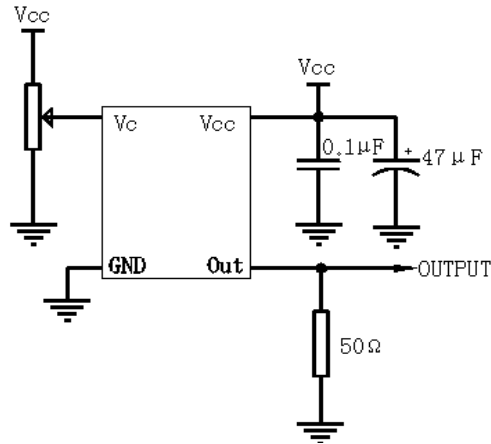

### 4. Reflow Soldering Curve (RoHS)



### 5. Package(mm)

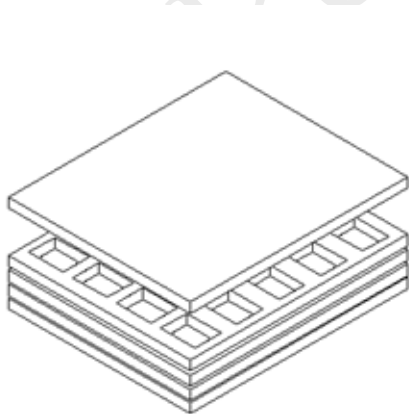

Buffer material

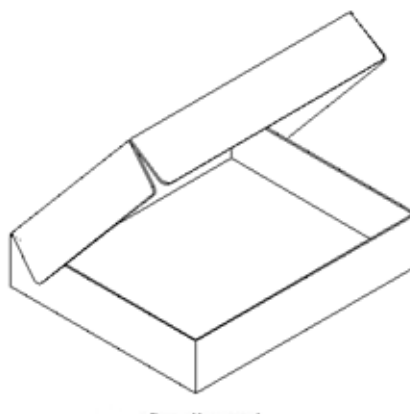

Cardboard  
Max 20pcs. circulator

