



1、Electrical Parameters

MODEL: O22S-2101-20.00MHZ						
Item	Description	Parameters			Unit	Test Condition
		Min.	Typ.	Max.		
Output	Frequency	20.00			MHz	
	Output Waveform	HCMOS				
	Output Low Voltage			0.4	V	$V_{cc}=3.3V, O_{load}=15pF$
	Output High Voltage	2.4			V	$V_{cc}=3.3V, O_{load}=15pF$
	Duty Cycle	45	50	55	%	@50%
	Rise / Fall Time (10%~90%)			10	ns	
	Load	15			pF	
	Spurious Suppression			-70	dBc	
	Jitter			1	ps	RMS(12KHz~10MHz)
Frequency Stabilities	Frequency Tolerance vs. Operating Temperature Range	-3		+3	$\times 10^{-9}$	T_A varied from $-40^{\circ}C$ to $85^{\circ}C$, measurement referenced to frequency observed with $f_{ref}=(f_{max}+f_{min})/2, V_{cc}=3.3V, O_{load}=15pF$, temperature variable speed less than $2^{\circ}C$ per minute.
	Initial Frequency Tolerance	-0.1		+0.1	$\times 10^{-6}$	Measurement referenced to frequency observed with $T_A=25^{\circ}C, V_{cc}=3.3V$, and after 15 minutes of operation, within 30 days after ex-works.
	Frequency Tolerance vs. Supply Voltage	-1		+1	$\times 10^{-9}$	measurement referenced to frequency observed $T_A=25^{\circ}C, V_{cc}$ varied from 3.13V to 3.47V, and $O_{Load}=15pF$.
	Frequency Tolerance vs. Load	-1		+1	$\times 10^{-9}$	5% load change measurement referenced to frequency observed with $T_A=25^{\circ}C, V_{cc}=3.3V, O_{Load}=15pF$.
	Short-Term Stability: Allan Variance			0.01	$\times 10^{-9}$	Temperature stability, no EMI\EMC or other interference, test after power for 1hour ref. to $25^{\circ}C; 1s$, using PN9000 equipment.
	Aging Tolerance Per Day	-1		+1	$\times 10^{-9}$	V_{cc}, T_A constant measurement referenced to frequency observed with $T_A=25^{\circ}C, V_{cc}=3.3V$, and after 30 days of operation.
	Aging Tolerance 30 Days	-0.03		+0.03	$\times 10^{-6}$	
	Aging Tolerance 1 Year	-0.1		+0.1	$\times 10^{-6}$	
	Aging Tolerance 10 Years	-0.8		+0.8	$\times 10^{-6}$	
	Aging Tolerance 20 Years	-1.5		+1.5	$\times 10^{-6}$	



	Holdover 24hours Drift	-1		+1	$\times 10^{-9}$	$V_{cc}=3.3V$, temperature change range $\pm 2.8^{\circ}C$, after 30 days of operation.
	Overall Stability	-4.6		+4.6	$\times 10^{-6}$	Inclusive of the following: - operating temperature $-40^{\circ}C$ to $85^{\circ}C$ - $3.3V \pm 5\%$ - 15pF load $\pm 5\%$ - 2 times reflow soldering - 20 years aging reference to nominal frequency
Stratum 3E compliant per GR-1244-CORE teleconcordia						
Power Supply	Supply Voltage	3.13	3.3	3.47	V	
	Steady Consumption			400	mA	@ $25^{\circ}C$
	Warm-Up Time			5	minutes	@ $25^{\circ}C$ within $\pm 0.1 \times 10^{-6}$ of final frequency with reference after 1 hour on.
	Warm up current			1000	mA	
Phase Noise	Phase Noise @ $25^{\circ}C$		-80	-70	dBc/Hz	1Hz
			-120	-110		10Hz
			-140	-130		100Hz
			-145	-140		1KHz
			-150	-145		10KHz
			-150	-145		100KHz
Environmental Conditions	Operable Temperature	-40		+85	$^{\circ}C$	
	Storage Temperature	-55		+105	$^{\circ}C$	
	ESD Level	Human Body Model,class2: 2000V to 4000V; ANSI/ESDA/JEDEC JS-001-2010.				
		Machine Model, class B: 200V to 400V; ANSI/ESDA/JEDEC JS-001-2010.				
	Moisture Sensitivity Level	Level 2.				
	Vibration	Test Condition: 0.75mm ;acceleration:10g;10Hz~500Hz, one cycle per 30 min, test 2 hour. (3 times for each 3 directions X ,Y , Z), IEC 68-2-06 Test Fc.				
Shock	50g; 11ms; half sine wave (3 times for each 3 directions X ,Y, Z),IEC 68-2-27 Test Ea/Severity 50A.					
Full Package Storage	Relative humidity (%)	20% ~ 70%				
	Temperature ($^{\circ}C$)	-10~35 $^{\circ}C$				



2、 Mechanical Structure(mm)

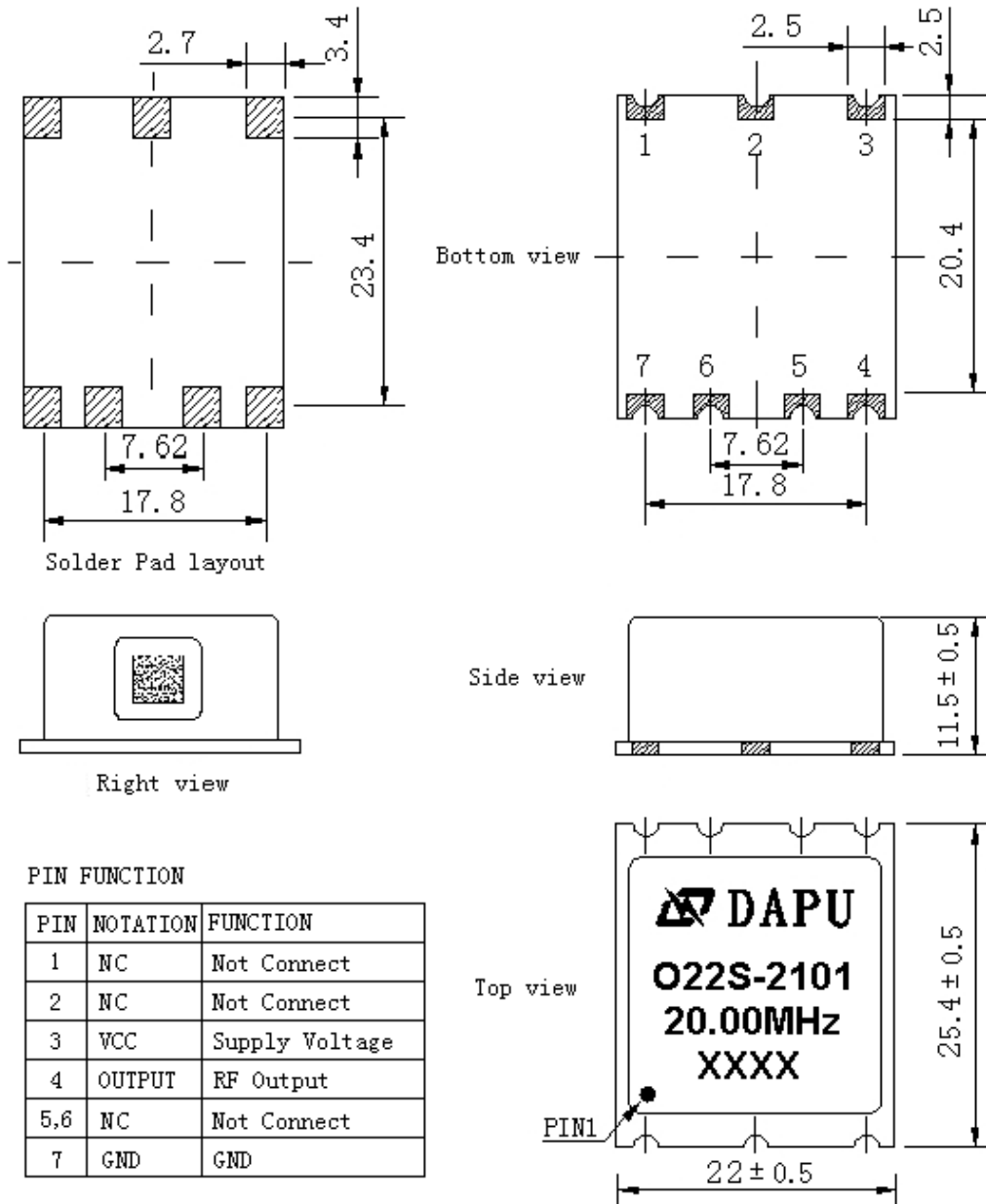

Note1: Tolerance $\pm 0.2\text{mm}$ without mark

Note2: The first two xx representative: week
After two xx representative: year

Note3: Referential Weight 18g

Note4: NC is not connect

Note5: Material composition :
Pad/terminals: Cu (Surface plating: Ni 3-6um, Au 0.1~0.5um)

Base: High-TG FR4

Cover: Stainless steel

Note6: Sealed product , can be washed in water. After washing, bake 2 hours at 105°C.



3、 Test Circuit

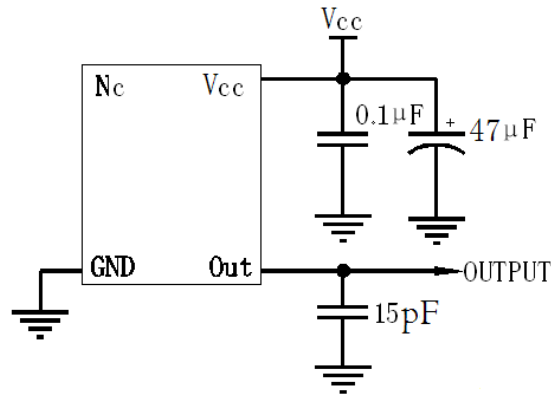

4、 Reflow Soldering Curve (RoHS)

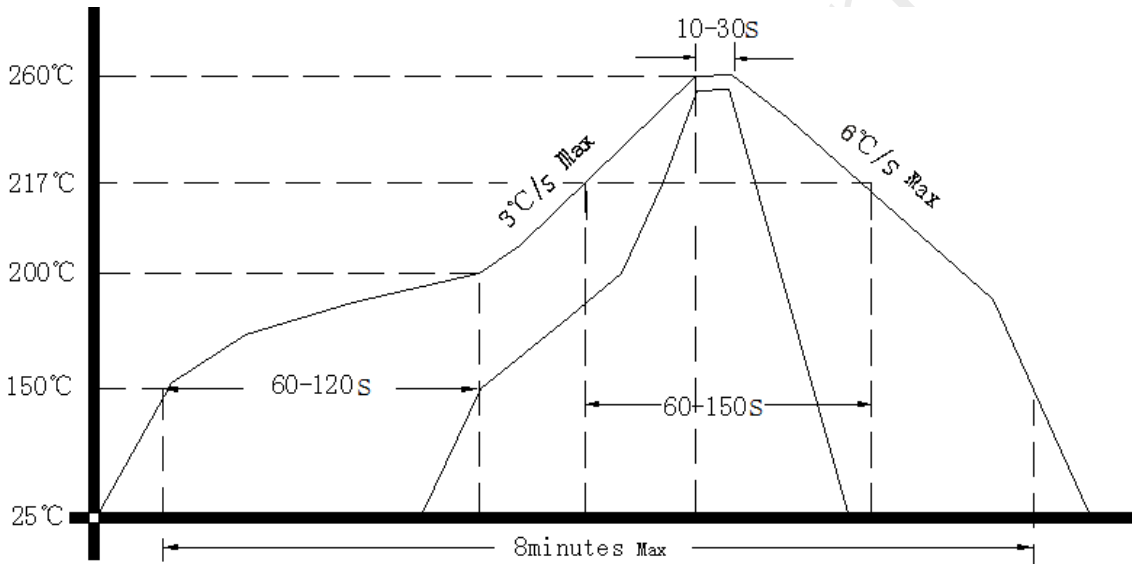

5、 Package (mm)

