

Customer Code : _____

DATASHEET

DAPU P/N: **T32-F517-12.80MHz**
(2P1280AACCU1)

Customer P/N: _____

DAPU			Customer Approval
Drew	Audited	Approved	Stamp, please! Thanks!
Date: 2016.01.13			

Guangdong Dapu Telecom Technology Co.,Ltd

Bldg 16,.N.Ind.Zone,SSL Industry Park, Dongguan City, Guangdong Province, China

TEL: 0086-0769-88010888 FAX: 0086-0769-81800098



1. Electrical Parameters

MODEL: T32-F517-12.80MHz						
Item	Description	Parameters			Unit	Test Condition
		Min.	Typ.	Max.		
Output	Frequency	12.80			MHz	
	Output Waveform	Clipped Sine Wave				
	Vp-p	0.8			V	
	Symmetry	40		60	%	GND level(DC cut)
	Load	10KΩ//10pF				
	Start Up			2.0	ms	@90% of final Vout level
Frequency Stabilities	Frequency Tolerance vs. Operating Temperature Range	-0.5		+0.5	$\times 10^{-6}$	T _A varied from -40°C to 85°C, referenced to frequency(T _A =25°C).
	Initial Frequency Tolerance	-1.5		+1.5	$\times 10^{-6}$	T _A =25°C, after 2 times reflow, referenced to nominal frequency.(Leave after reflow more than 2 hours at room ambient)
	Frequency Tolerance vs. Supply Voltage	-0.2		+0.2	$\times 10^{-6}$	measurement referenced to frequency observed T _A =25°C, V _{cc} varied from 3.135V to 3.465V, and O _{Load} =10KΩ//10pF.
	Frequency Tolerance vs. Load	-0.2		+0.2	$\times 10^{-6}$	10% load change measurement referenced to frequency observed with T _A =25°C, V _{cc} =3.3V, and O _{Load} =10KΩ//10pF.
	Aging Tolerance 10 Years	-3		+3	$\times 10^{-6}$	T _A =Room ambient
Power Supply	Operating Current			1.5	mA	
	Supply Voltage	3.135	3.3	3.465	V	
Voltage Control	Frequency Tuning Range	±20			$\times 10^{-6}$	V _c =1.5V±1.0V
	Slope	Positive				
	Input Impedance	500			KΩ	
Phase Noise	Phase Noise			-135	dBc/Hz	1KHz



Environmental Conditions	Operable Temperature	-40		+85	°C	
	Storage Temperature	-40		+85	°C	
	ESD Level	Human Body Model,class2: 2000V to 4000V; ANSI/ESDA/JEDEC JS-001-2010.				
		Machine Model, class B: 200V to 400V; ANSI/ESDA/JEDEC JS-001-2010.				
	Moisture Sensitivity Level	Level 2.				
	Vibration	Test Condition: 0.75mm ;acceleration:10g;10Hz~2000Hz, one cycle per 30 min, test 2 hour. (3 times for each 3 directions X ,Y , Z) .IEC 68-2-06 Test Fc.				
Shock	100g; 6ms; half sine wave (3 times for each 3 directions X ,Y , Z),IEC 68-2-27 Test Ea/Severity 50A.					
Full Package Storage	Relative humidity (%)	20% ~70%				
	Temperature (°C)	-10~35°C				

DAPU Confidential



2. Mechanical Structure(mm)

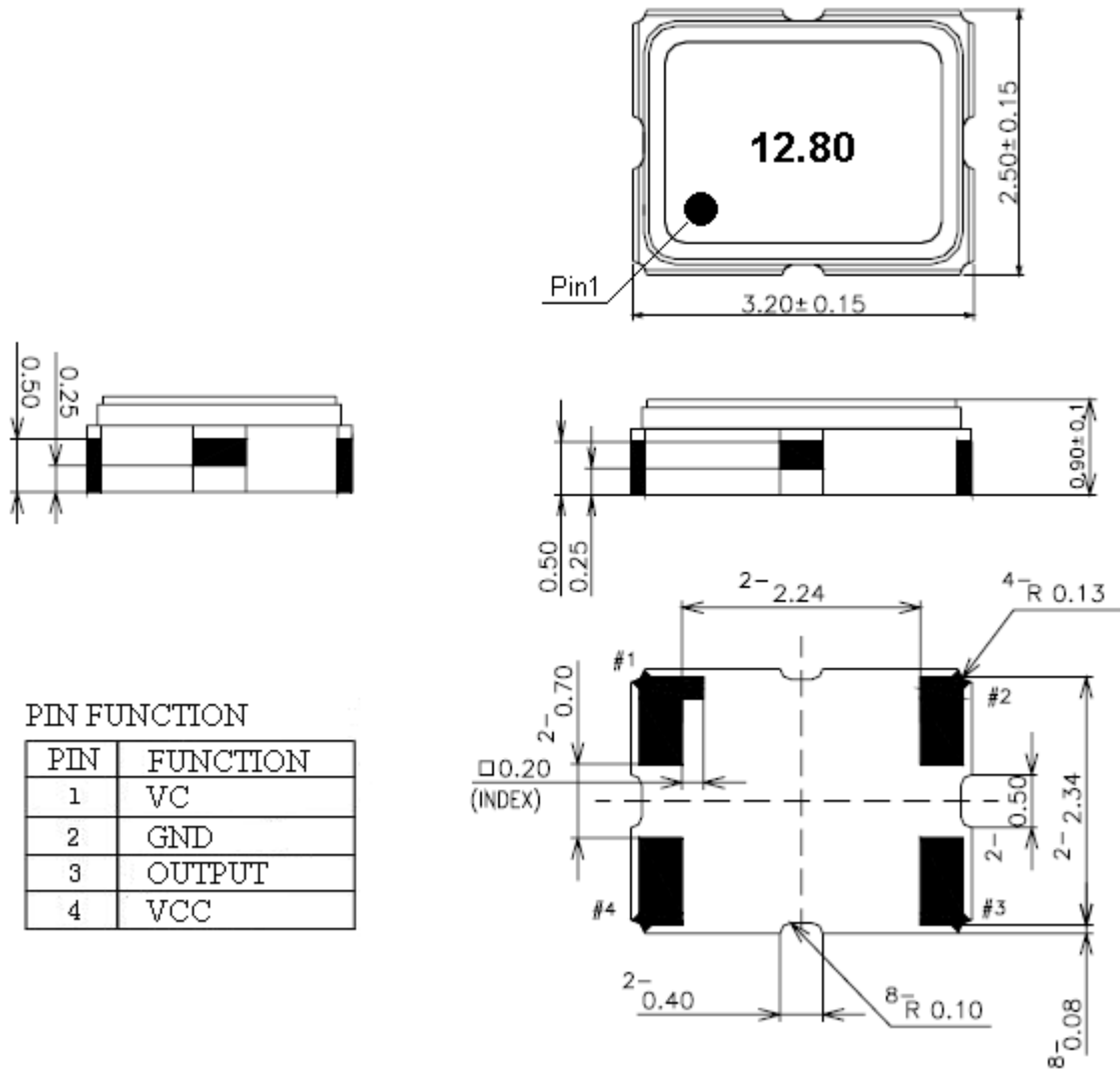

PIN FUNCTION

PIN	FUNCTION
1	VC
2	GND
3	OUTPUT
4	VCC

Note1: Tolerance ±0.15mm without mark

Note2: Referential Weight 0.03g

DAPU



3. Test Circuit

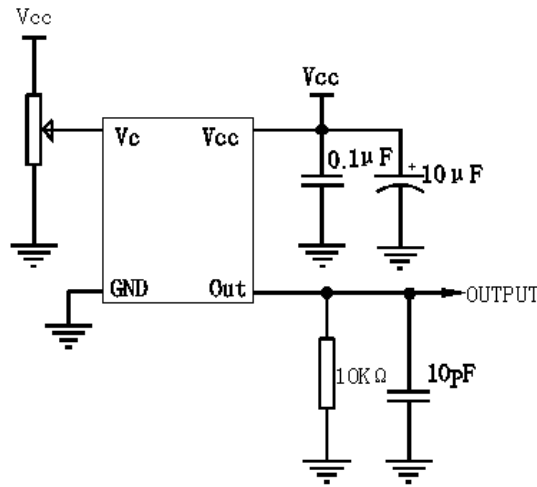

4. Reflow Soldering Curve (RoHS)

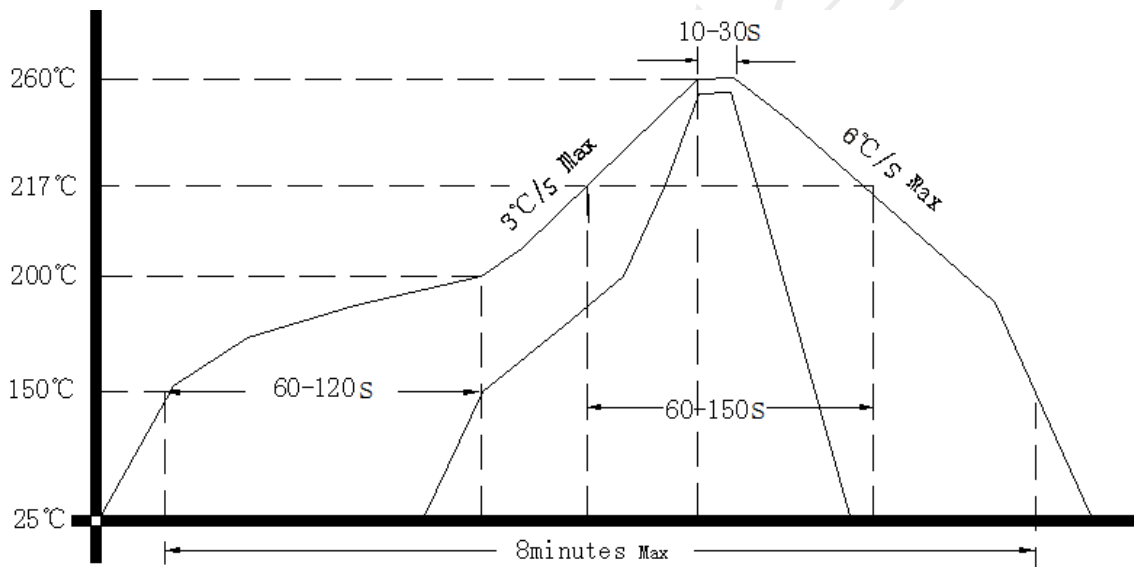

5. Package: Tape & Reel (mm)

