

Customer Code: _____

DATASHEET

DAPU P/N: DP7W50000010

Y75NNM5000A

DAPU			Customer Approval
Drew	Audited	Approved	Stamp, please! Thanks!
Date: 2015.08.05			

Guangdong Dapu Telecom Technology Co.,Ltd

Bldg 16,.N.Ind.Zone,SSL Industry Park, Dongguan City, Guangdong Province, China

TEL: 0086-0769-88010888 FAX: 0086-0769-81800098



1、 Electrical Parameters

MODEL: DP7W5000010							
No	Parameters	SYM.	Electrical Spec.				Notes
			Min.	Typ.	Max.	Units	
1	Nominal Frequency	FL	50.00			MHz	
2	Frequency Stability	-	-30		+30	$\times 10^{-6}$	-40°C~85°C
3	Frequency Tolerance	-	-20		+20	$\times 10^{-6}$	@25°C
4	Operating Temperature	Topr	-40	~	85	°C	
5	Storage Temperature	Tstg	-40	~	85	°C	
6	Supply Voltage	VDD	3.3			V	
7	Input Current	Icc	-	-	30	mA	
8	Output Load: CMOS	CL	15			pF	
9	Output Voltage High	VoH	0.9Vdd	-	-	V	
10	Output Voltage Low	VoL	-	-	0.1Vdd	V	
11	Rise Time	Tr	-	-	6	ns	10%-90% VDD Level
12	Fall Time	Tf	-	-	6	ns	90%-10% VDD Level
13	Symmetry (Duty ratio)	TH/T	45	~	55	%	
14	Aging	-	± 3			$\times 10^{-6}/\text{yr.}$	Year at 25°C
15	Start-up Time	-	-	-	10	ms	
16	ESD Level	Human Body Model,class2: 2000V to 4000V; ANSI/ESDA/JEDEC					
		Machine Model, class B: 200V to 400V; ANSI/ESDA/JEDEC JS-001-2010.					
17	Moisture Sensitivity Level	Level 2.					
18	Vibration	Test Condition: 0.75mm ;acceleration:10g;10Hz~2000Hz, one cycle per 30 min, test 2 hour. (3 times for each 3 directions X , Y , Z) .IEC 68-2-06 Test Fc.					
19	Shock	100g; 6ms; half sine wave (3 times for each 3 directions X , Y , Z),IEC 68-2-27 Test Ea/Severity 50A.					
20	Full Package Storage	Relative humidity (%)			20% ~ 70%		
		Temperature (°C)			-10~35°C		



2、 Mechanical Structure(mm)

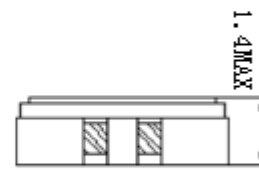
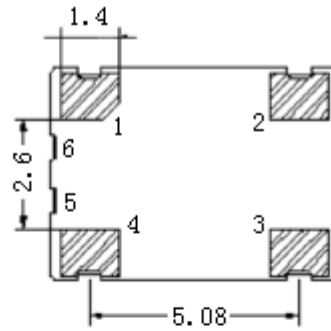
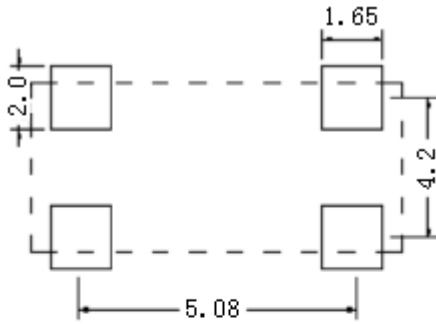

PIN FUNCTION

PIN	FUNCTION
1	Tristate
2	GND
3	Output
4	Voltage Control
5	Crystal
6	Crystal

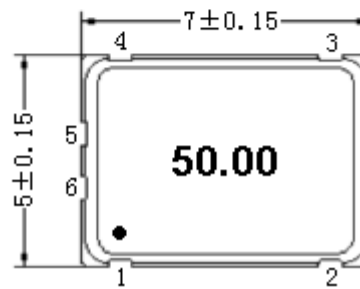

Note1: Tolerance $\pm 0.20\text{mm}$



3、Reflow Soldering Curve (RoHS)

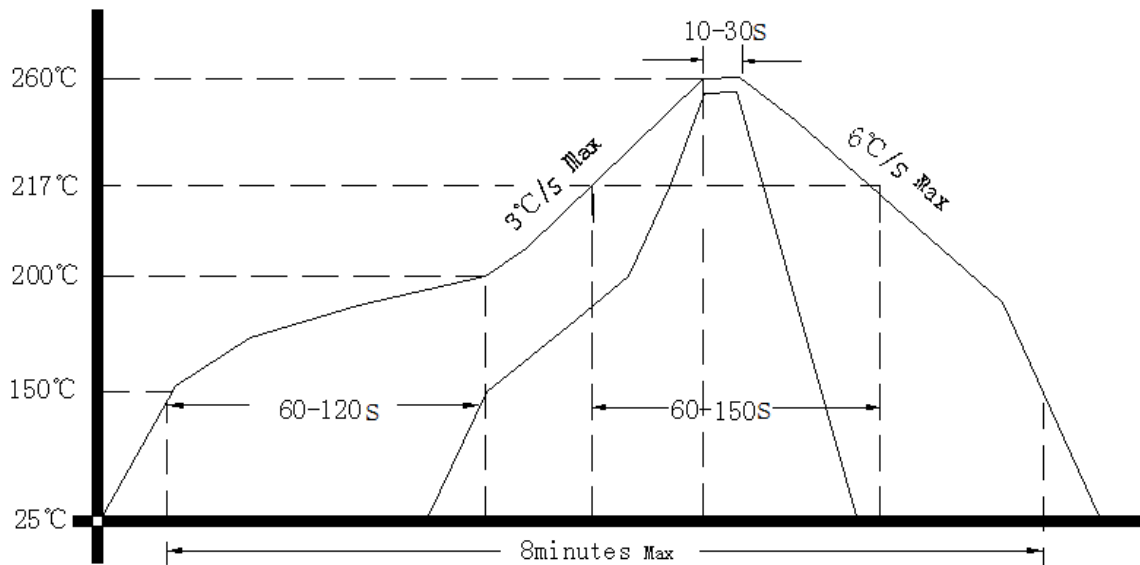

4、Package: Tape & Reel (mm)

