

Travelling Merchant: _____

DATASHEET

Standard: **O22S-X320-26.00MHz**

P/N: _____

Plot			The Label
Drew	Audited	Approved	Stamp, please! Thanks!
Date: 2013.02.01			

Guangdong Dapu Telecom Technology Co.,Ltd

Bldg13-16,.N.Ind.Zone,SSL Industry Park, Dongguan City, Guangdong Province, China

TEL: 0086-0769-88010888 FAX: 0086-0769-81800098



Table of amendment

Version	Revision contents	Prepared by	Revised date
1.0	The first issued	<i>Amway</i>	2011.12.14
1.1	Short-Term Stability: Allan Variance change to 0.008×10^{-9}	<i>Amway</i>	2013.02.01



1. Electrical Parameters

MODEL: O22S-X320-26.00MHz						
Item	Description	Parameters			Unit	Test Condition
		Min.	Typ.	Max.		
Output	Frequency	26.00			MHz	
	Output Start up Time			200	ms	
	Output Waveform	HCMOS				
	Output Low Voltage			0.5	V	$V_{cc}=5.0V, O_{load}=15pF$
	Output High Voltage	4.0			V	$V_{cc}=5.0V, O_{load}=15pF$
	Duty Cycle	40	50	60	%	@50%
	Rise / Fall Time (10%~90%)			15	ns	$V_{cc}=5.0V, O_{load}=15pF$
	Load	15			pF	
	Sub Harmonics			-40	dBc	
	13MHz, 8.6666MHz and their odd multiples			-25	dBc	
Frequency Stabilities	Frequency Tolerance vs. Operating Temperature Range	-10		+10	$\times 10^{-9}$	T_A varied from $-10^{\circ}C$ to $85^{\circ}C$, measurement referenced to frequency observed with $T_A = 25^{\circ}C$, $V_{cc}=5.0V$, $V_c=2.0V$, $O_{load}=15pF$, temperature variable speed less than $2^{\circ}C$ per minute.
	Initial Frequency Tolerance	-0.2		+0.2	$\times 10^{-6}$	Measurement referenced to frequency observed with $T_A=25^{\circ}C$, $V_{cc}=5.0V$, $V_c=2.0V$, After 24 hours of operation (during the 1st month of operation).
	Frequency Tolerance vs. Supply Voltage	-1		+1	$\times 10^{-9}$	measurement referenced to frequency observed $T_A=25^{\circ}C$, V_{cc} varied from 4.75V to 5.25V, $V_c=2.0V$ and $O_{Load}=15pF$.
	Frequency Tolerance vs. Load	-1		+1	$\times 10^{-9}$	5% load change measurement referenced to frequency observed with $T_A= 25^{\circ}C$, $V_{cc}=5.0V$, $V_c=2.0V$, and $O_{Load}=15pF$.
	Short-Term Stability: Allan Variance			0.025	$\times 10^{-9}$	Temperature stability, no EMI/EMC or other interference, test after power for 1hour ref. to $25^{\circ}C$; 1ms, using PN9000 equipment.



	Short-Term Stability: Allan Variance			0.008	$\times 10^{-9}$	Temperature stability, no EMI\EMC or other interference, test after power for 1hour ref. to 25°C; 0.1s , using PN9000 equipment.	
	Aging Tolerance Per Day	-0.8		+0.8	$\times 10^{-9}$	V_{cc}, V_c, T_A constant measurement referenced to frequency observed with $T_A=40^\circ C, V_{cc}=5.0V, V_c=2.0V$, and after 30 days of operation	
	Aging Tolerance Per Month	-0.016		+0.016	$\times 10^{-6}$		
	Aging Tolerance 1 Year	-0.04		+0.04	$\times 10^{-6}$		
Power Supply	Overall Stability	-0.05		+0.05	$\times 10^{-6}$	Inclusive of the following: - operating temperature $-10^\circ C$ to $85^\circ C$ - $5.0V \pm 5\%$ - $V_c=2.0V$ - 15pF load $\pm 5\%$ - 1 year aging After 30 days of continuous operation.	
	Supply Voltage	4.75	5.0	5.25	V		
	Steady Consumption				500	mA	@0°C
					300	mA	@25°C
					120	mA	@65°C
	Warm up Time				5	minutes	@25°C within $\pm 0.05 \times 10^{-6}$ of final frequency with reference after 1 hour on.
					8	minutes	@0°C within $\pm 0.05 \times 10^{-6}$ of final frequency with reference after 1 hour on.
Warm up Current				800	mA		
Voltage Control Characteristics	Frequency Tuning Range	-1.5		-0.7	$\times 10^{-6}$	$V_c=0V$. measurement referenced to $V_c=2.0V$	
		-0.05		+0.05	$\times 10^{-6}$	$V_c=2.0V$. measurement referenced to exactly 26.00MHz	
		+0.7		+1.5	$\times 10^{-6}$	$V_c=4.0V$. measurement referenced to $V_c=2.0V$	
	Linearity			10	%		
	Slope	Positive					
	Input Impedance	200				KΩ	



Vref output	Reference Voltage	3.8		4.2	V	T _A = 25 °C
	Load Current			1	mA	T _A = 25 °C
	Internal Resistance Value			10	Ω	T _A = 25 °C
	Stability Versus Operating Temperature			5	mV	That means between -10 °C to 85 °C
	Stability Versus Supply Voltage			2	mV	T _A = 25 °C
Phase Noise	Phase Noise			-70	dBc/Hz	1Hz
				-90		10Hz
				-120		100Hz
				-140		1KHz
				-145		10KHz
Environmental Conditions	Operable Temperature	-40		+85	°C	
	Storage Temperature	-55		+105	°C	
	ESD Level	Human Body Model,class2: 2000V to 4000V; ANSI/ESDA/JEDEC JS-001-2010.				
		Machine Model, class B: 200V to 400V; ANSI/ESDA/JEDEC JS-001-2010.				
	Vibration	Test Condition: 0.75mm ;acceleration:5g;9Hz~200Hz, one cycle per 30 min, test 2 hour. (3 times for each 3 directions X ,Y , Z), IEC 68-2-06 Test Fc.				
	Shock	5 m/s ² ; 11ms; half sine wave (3 times for each 3 directions X ,Y , Z),IEC 68-2-27 Test Ea/Severity 50A.				
Humidity	IEC 60068-2-30					



2. Remote Inventory

2.1 Characteristic frequency sample points

We provided The tuning behaviour of the OCXO ($F=f(v_c)$) in terms of 11 equidistant frequency sample points F_i on an integral Flash memory.

The equidistant tuning voltage increment has to be $dv_c = 4V/10$.

Therefore the equidistant tuning voltage samples will be $v_{ci} = 0 + (i-1)*dvc$, with $i=1$ to 11 (see 2.1.1, Definitions)

2.1.1 Definitions

$n \equiv$ number of sample points, $n=11$

$i \equiv$ index

$v_{c_{min}} \equiv 0V$

$v_{c_{max}} \equiv 4V$

$F_i \equiv$ equidistant frequency sample

$v_c \equiv$ tuning voltage

$dvc \equiv$ tuning voltage increment, $(v_{c_{max}} - v_{c_{min}}) / (n-1) \rightarrow 0.4V$

2.1.2 Format of the frequency readings

The frequency readings is applied as follows:

Typical frequency readings F_i :

e. g. $F_1 = 25\ 999\ 971.35\ Hz \rightarrow F_1 = 97135$ (no decimal point in the data)

e. g. $F_2 = 26\ 000\ 031.49\ Hz \rightarrow F_2 = 03149$

Only the five last digits, without a decimal point have to get written into the Flash.

Confer to 2.1.3, Coding requirement of the characteristic frequency samples in the Flash memory.

2.1.3 Coding requirements of the characteristic frequency samples in the Flash memory

Manufacturers name, Crystal Oscillator Type, Date Code, Serial number without blanks = 16 characters

One blank = 1 characters

11*5 Frequency samples without blanks = 55 characters

72 characters

e. g. Manufacturers name = DAPU

Crystal Oscillator Type=O

Date Code = 0429 year, calendar week

Serial number = xxx1234

One blank



First frequency sample = 96337, second one = 96804... ..eleventh = 04491

DAPUO0429xxx1234 9633796804975679822498949997700067401634026080356704491

2.1.4 Accuracy for the frequency measurement

The frequency measurement is accomplished by means of a two-digit mantissa reading, like e.g. 25 999 971.35 (rounded)

The frequency measurement itself is implemented with an accuracy of at least better than $F_i \pm 0.19\text{ppb}$, (This results from $\pm 5\text{mHz} \equiv \pm 0.19\text{ppb}$).

2.1.5 Accuracy and stability to set the tuning voltage

During the whole measurement, the accordant tuning voltage v_{ci} is set with a relative accuracy of better than $v_{ci} \pm 0.5\text{mV}$ and the tuning voltage stability is maintained better than $v_{ci} \pm 0.1\text{mV}$.

2.2 The integral Flash memory

The Flash memory is a 3.3V serial I2C-bus EEPROM.

Storage capacity: 16kByte

SDA (input/ output) -> 3.3V HCMOS, with an integral pull up 50K Ω

SCL (input) -> 3.3V HCMOS, with an integral pull up 50K Ω

Address: 1010 000



3. Mechanical Structure (mm)

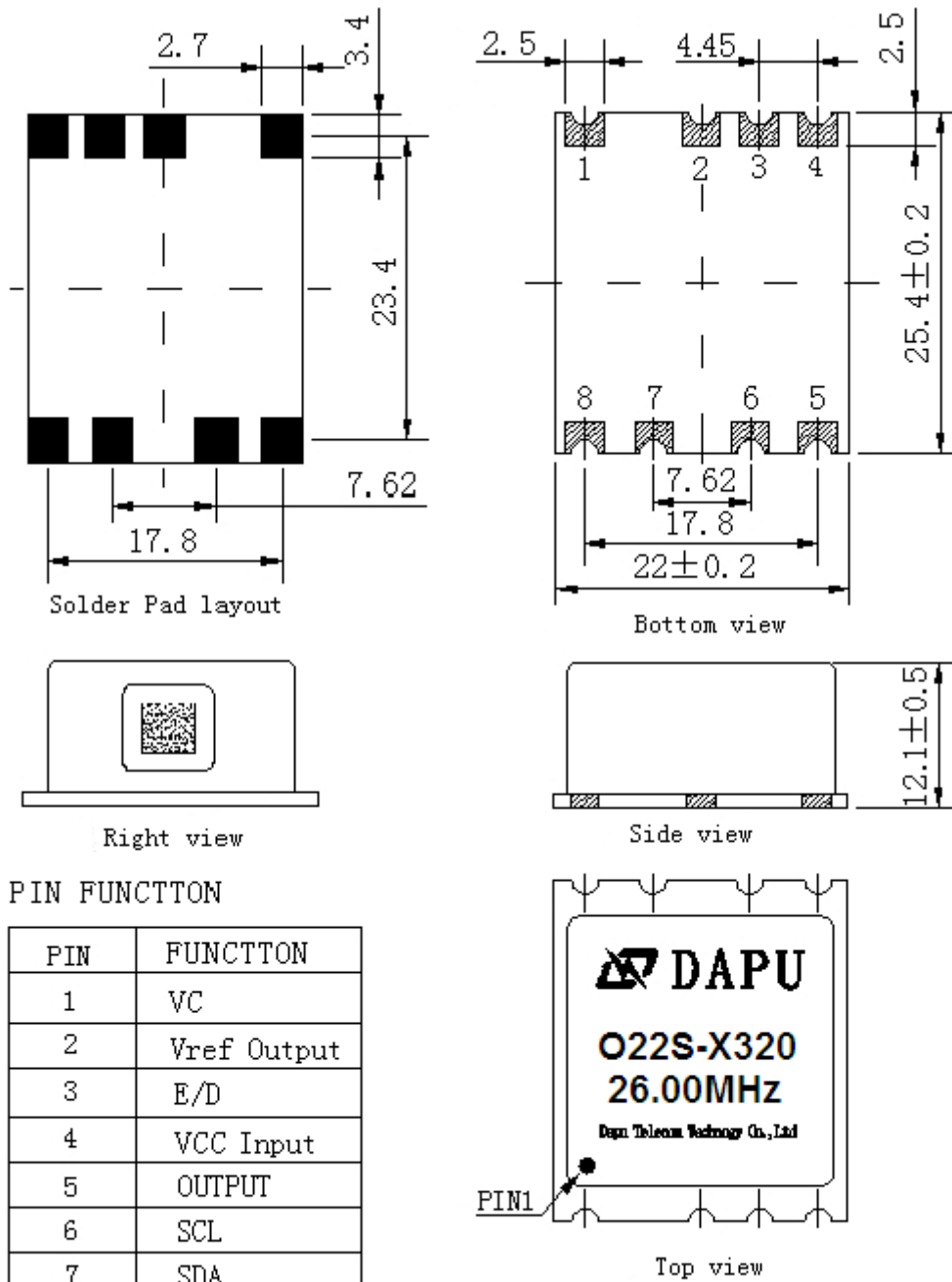

PIN FUNCTION

PIN	FUNCTON
1	VC
2	Vref Output
3	E/D
4	VCC Input
5	OUTPUT
6	SCL
7	SDA
8	GND

- Note1:** Tolerance ± 0.2mm without mark
- Note2:** Referential Weight 20g
- Note3:** Output E/D:
 "0" -> output disabled (high Z)
 "1" -> output enabled
 "open/ no connection" -> output enabled



4. Test Circuit

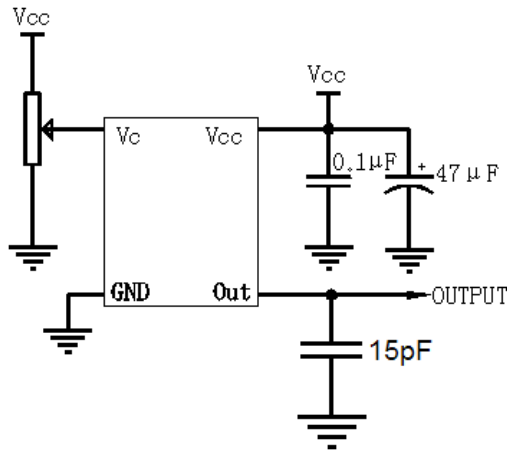

5. Reflow Soldering Curve (RoHS)

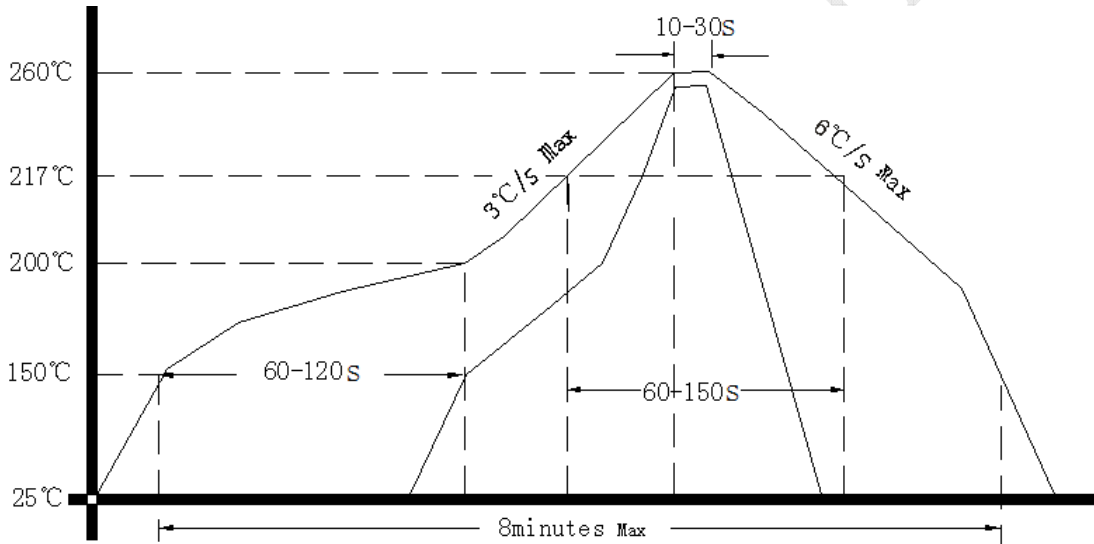

6. Package (mm)

