

Customer Code: _____

DATASHEET

DAPU P/N: DP9B08000007JSX1S0800007

DAPU			Customer Approval
Drew	Audited	Approved	Stamp, please! Thanks!
Date: 2015.05.08			

Guangdong Dapu Telecom Technology Co.,Ltd

Bldg13-16,.N.Ind.Zone,SSL Industry Park, Dongguan City, Guangdong Province, China

TEL: 0086-0769-88010888 FAX: 0086-0769-81800098



1. Electrical Parameters

MODEL: DP9B0800007							
No.	Parameters	SYM.	Electrical Spec.				Notes
			Min.	Typ.	Max.	Units	
1	Nominal Frequency	FL	8.00			MHz	
2	Oscillation Mode	-	Fundamental			-	
3	Cut	-	AT			-	
4	Load Capacitance	CL	20			pF	
5	Frequency Tolerance	-	-20	~	+20	$\times 10^{-6}$	at 25°C
6	Stability Over Temperature Range	-	-30	~	+30	$\times 10^{-6}$	related to 25°C
7	Operating Temperature Range	-	-20	~	+70	°C	
8	Storage Temperature	-	-40	~	+85	°C	
9	Aging	-	-3	~	+3	$\times 10^{-6}$	1st Year
10	Drive Level	DL	-	10	-	uW	
11	Effective Series Resistance	ESR	-	-	60	Ω	
12	Shunt Capacitance C0	C0	-	-	5	pF	
13	Insulation Resistance		500			M Ω	at DC 100V
14	ESD Level	Human Body Model,class2: 2000V to 4000V; ANSI/ESDA/JEDEC JS-001-2010.					
		Machine Model, class B: 200V to 400V; ANSI/ESDA/JEDEC JS-001-2010.					
15	Moisture Sensitivity Level	Not humidity sensitive.					
16	Vibration	Test Condition: 0.75mm ;acceleration:10g;10Hz~2000Hz, one cycle per 30 min, test 2 hour. (3 times for each 3 directions X , Y , Z) .IEC 68-2-06 Test Fc.					
17	Shock	100g; 6ms; half sine wave (3 times for each 3 directions X , Y , Z),IEC 68-2-27 Test Ea/Severity 50A.					
18	Full Package Storage	Relative humidity (%)		20%~70%			
		Temperature (°C)		-10~35°C			



2. Mechanical Structure (mm)

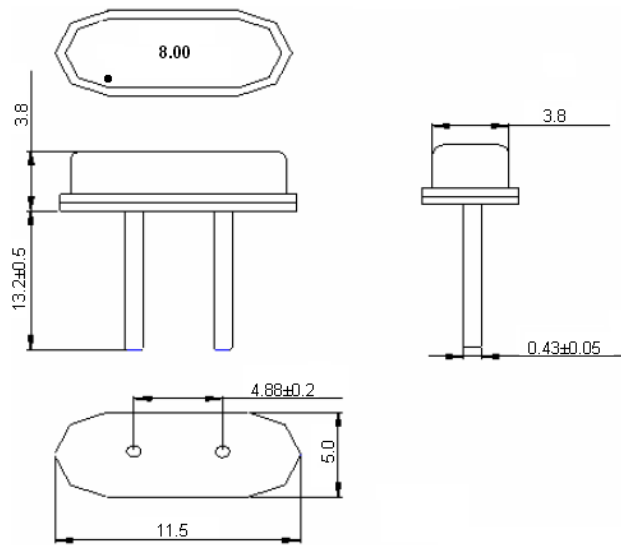

Note1: Tolerance ±0.2mm

3. Wave Soldering Curve (RoHS)

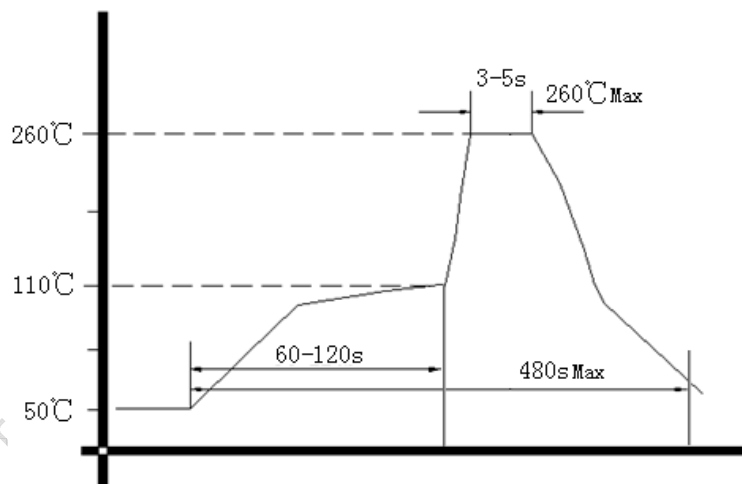

4.Package

