

Customer Code : _____

DATASHEET

DAPU P/N: 054B-Q349-10.00MHz

Customer P/N: _____

DAPU			Customer Approval
Drew	Audited	Approved	Stamp, please! Thanks!
Date: 2015.05.07			

Guangdong Dapu Telecom Technology Co.,Ltd

Bldg13-16,.N.Ind.Zone,SSL Industry Park, Dongguan City, Guangdong Province, China

TEL: 0086-0769-88010888 FAX: 0086-0769-81800098



1. Electrical Parameters

MODEL: O54B-Q349-10.00MHz						
Item	Description	Parameters			Unit	Test Condition
		Min.	Typ.	Max.		
Output	Frequency	10.00			MHz	
	Output Waveform	HCMOS				
	Output Low Voltage			0.4	V	$V_{cc}=12.0V, O_{load}=15pF$
	Output High Voltage	2.7			V	$V_{cc}=12.0V, O_{load}=15pF$
	Duty Cycle	40	50	60	%	@50%
	Rise / Fall Time (10%~90%)			10	ns	@25°C
	Load	15			pF	
Frequency Stabilities	Frequency Tolerance vs. Operating Temperature Range	-0.01		+0.01	$\times 10^{-6}$	T_A varied from -25°C to 75°C, measurement referenced to frequency observed with $f_{ref}=(f_{max}+f_{min})/2, V_{cc}=12.0V, O_{load}=15pF$, temperature variable speed less than 2°C per minute.
	Initial Frequency Tolerance	-0.01		+0.01	$\times 10^{-6}$	Measurement referenced to frequency observed with $T_A=25^\circ C, V_{cc}=12.0V$, at the time of shipment
		-0.05		+0.05	$\times 10^{-6}$	Measurement referenced to frequency observed with $T_A=25^\circ C, V_{cc}=12.0V$, and after 30 minutes of operation, within 90 days after ex-works
	Frequency Tolerance vs. Supply Voltage	-2		+2	$\times 10^{-9}$	measurement referenced to frequency observed $T_A=25^\circ C, V_{cc}$ varied from 11.4V to 12.6V, and $O_{Load}=15pF$.
	Frequency Tolerance vs. Load	-2		+2	$\times 10^{-9}$	5% load change measurement referenced to frequency observed with $T_A=25^\circ C, V_{cc}=12.0V$, and $O_{Load}=15pF$.
	Short-Term Stability: Allan Variance			0.01	$\times 10^{-9}$	Temperature stability, no EMI\EMC or other interference, test after power for 1hour ref. to 25°C; 1s, using PN9000 equipment.
	Aging Tolerance Per Day	-3		+3	$\times 10^{-9}$	V_{cc}, T_A constant measurement referenced to frequency observed with $T_A=25^\circ C, V_{cc}=12.0V$, and after 30 days of operation.
Aging Tolerance 1 Year	-0.1		+0.1	$\times 10^{-6}$		
Power Supply	Supply Voltage	11.4	12.0	12.6	V	
	Current Consumption			150	mA	@25°C
	Warm up current			450	mA	



Mechanical Adjust	Frequency Adjust Range			-0.5	$\times 10^{-6}$	All Frequency Adjust Range.
		+0.5			$\times 10^{-6}$	
Phase Noise	Phase Noise @25°C		-125	-115	dBc/Hz	10Hz
			-145	-135		100Hz
			-150	-145		1KHz
			-155	-150		10KHz
			-155	-150		100KHz
			-155	-150		1MHz
Environmental Conditions	Operable Temperature	-25		+75	°C	
	Storage Temperature	-55		+105	°C	
	ESD Level	Human Body Model, class2: 2000V to 4000V; ANSI/ESDA/JEDEC JS-001-2010.				
		Machine Model, class B: 200V to 400V; ANSI/ESDA/JEDEC JS-001-2010.				
	Moisture Sensitivity Level	Not humidity sensitive.				
	Vibration	Test Condition: 0.75mm ;acceleration:10g;10Hz~500Hz, one cycle per 30 min, test 2 hour. (3 times for each 3 directions X , Y , Z), IEC 68-2-06 Test Fc.				
Shock	50g; 11ms; half sine wave (3 times for each 3 directions X , Y , Z),IEC 68-2-27 Test Ea/Severity 50A.					
Full Package Storage	Relative humidity (%)	20%~70%				
	Temperature (°C)	-10~35°C				



2. Mechanical Structure(mm)

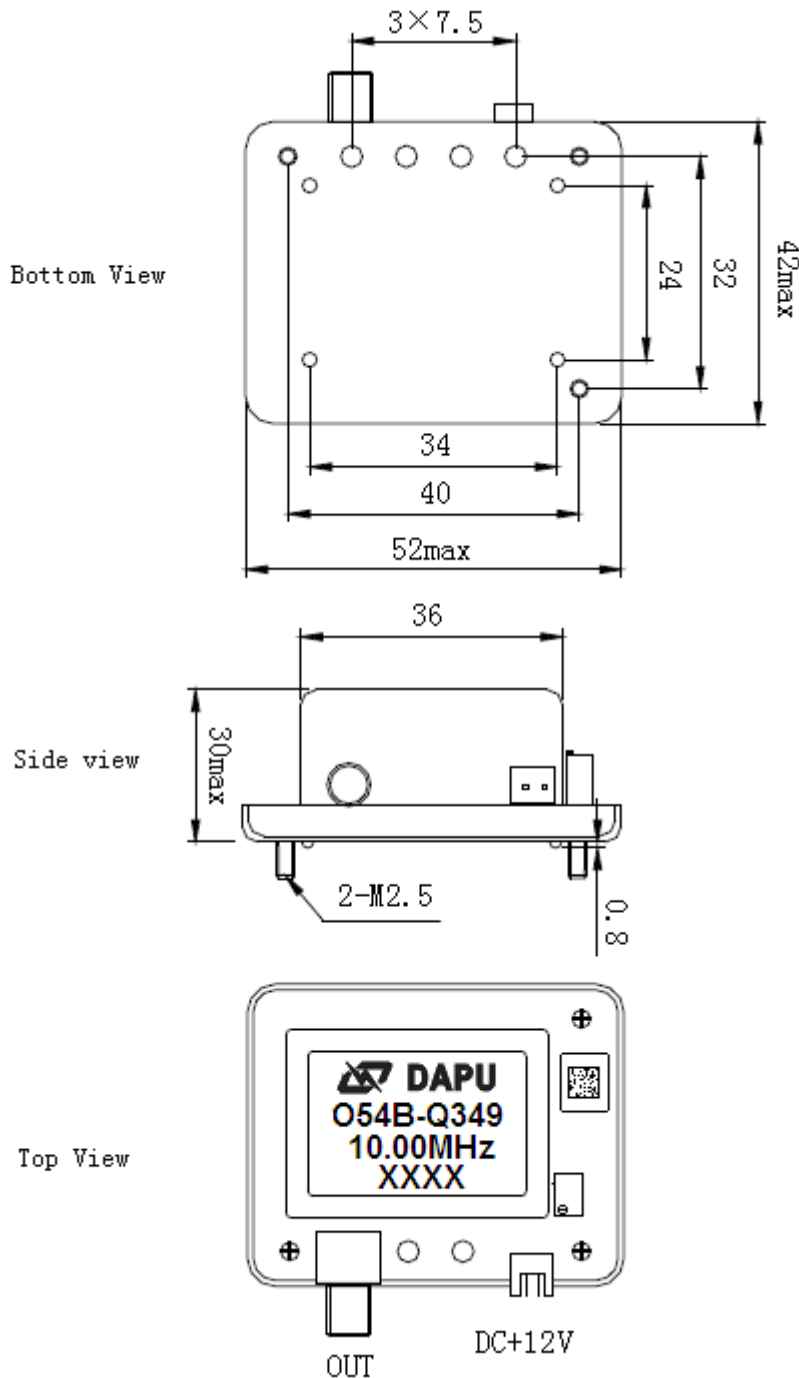

- Note1:** Tolerance $\pm 0.2\text{mm}$ without mark
- Note2:** The first two xx representative: week
After two xx representative: year
- Note3:** Referential Weight 65g



4. Test Circuit

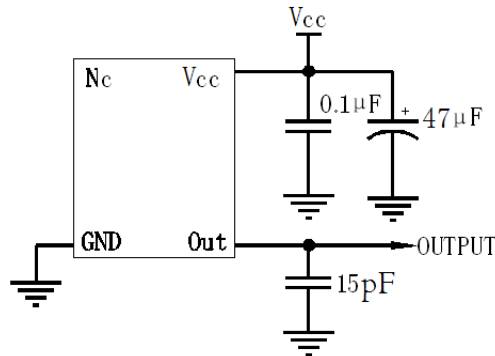

5. Reflow Soldering Curve (RoHS)

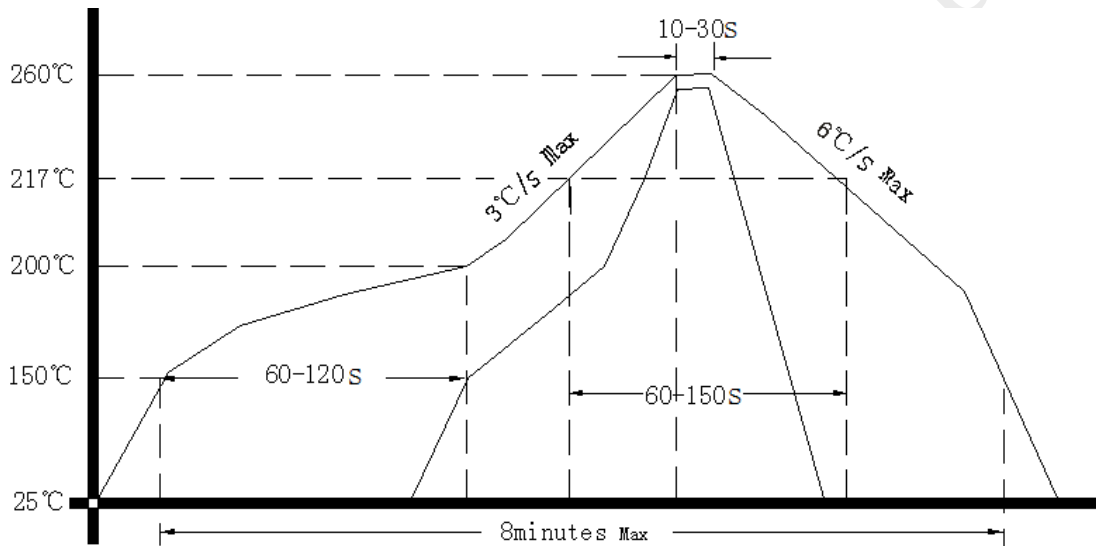

6. Package(mm)

