

Customer Code: _____

DATASHEET

DAPU P/N: DP7C66660002Y53ZCYS66661

DAPU			Customer Approval
Drew	Audited	Approved	Stamp, please! Thanks!
Date: 2015.03.30			

Guangdong Dapu Telecom Technology Co.,Ltd

Bldg13,,N.Ind.Zone,SSL Industry Park, Dongguan City, Guangdong Province, China

TEL: 0086-0769-88010888 FAX: 0086-0769-81800098



1、Electrical Parameters

MODEL: DP7C66660002							
No.	Parameters	SYM.	Electrical Spec.				Notes
			Min.	Typ.	Max.	Units	
1	Nominal Frequency	FL	66.666			MHz	
2	Output Waveform		CMOS				
3	Oscillation mode		Overtone				
4	Frequency Stability	-	-30		+30	$\times 10^{-6}$	Incl.25°C tolerance, tolerance over operating temperature range, input Voltage change, load change,1 year aging
5	Operating Temperature	Topr	-40	~	+85	°C	
6	Storage Temperature	Tstg	-55	~	+125	°C	
7	Supply Voltage	VDD	1.8±10%			V	
8	Input Current	Icc	-	-	45	mA	
9	Output Load:	CL	15			pF	
10	Aging	-	-3	-	+3	$\times 10^{-6}$ /yr.	1st. Year at 25°C
11	Output Voltage High	VoH	90% Vdd	-	-	V	
12	Output Voltage Low	Vol	-	-	10% Vdd	V	
13	Rise Time	Tr	-	-	5	ns	10%-90% VDD Level
14	Fall Time	Tf	-	-	5	ns	90%-10% VDD Level
15	Start-up Time	Tosc	-	-	10	ms	
16	Standby current				10	μ A	
17	Phase Jitter (rms):				1	pS	12KHz to 20MHz
18	Output State Control		Enable/disable				
19	ESD Level	Human Body Model,class2: 2000V to 4000V; ANSI/ESDA/JEDEC JS-001-2010.					
		Machine Model, class B: 200V to 400V; ANSI/ESDA/JEDEC JS-001-2010.					
20	Moisture Sensitivity Level	Level 2.					
21	Vibration	Test Condition: 0.75mm ;acceleration:10g;10Hz~2000Hz, one cycle per 30 min, test 2 hour. (3 times for each 3 directions X , Y , Z) .IEC 68-2-06 Test Fc.					
22	Shock	100g; 6ms; half sine wave (3 times for each 3 directions X , Y , Z),IEC 68-2-27 Test Ea/Severity 50A.					
23	Full Package Storage	Relative humidity (%)		20% ~70%			
		Temperature (°C)		-10~35°C			



2、 Mechanical Structure(mm)

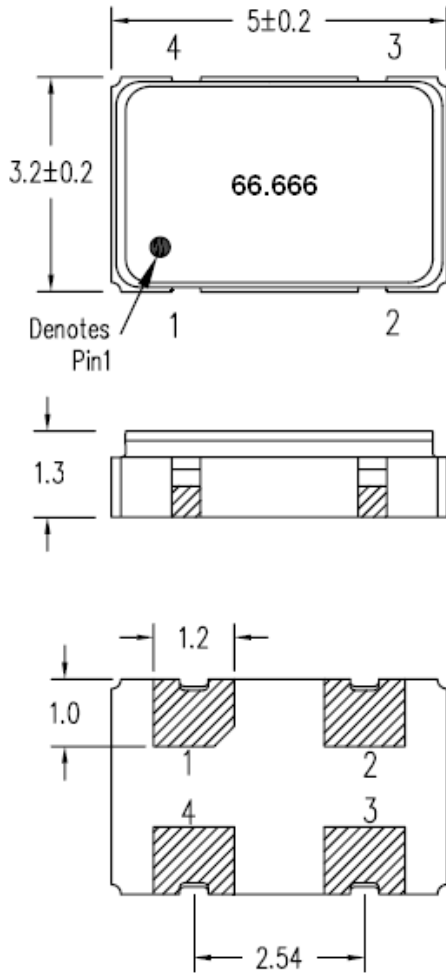

PAD NO.	Connection
1	E/D
2	GND
3	Output
4	VDD

Recommended Soldering Pattern

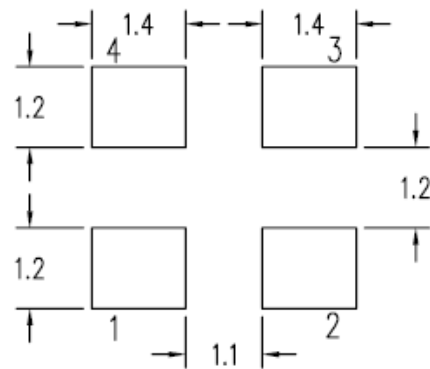

Notel: Tolerance $\pm 0.2\text{mm}$

3、 Reflow Soldering Curve (RoHS)

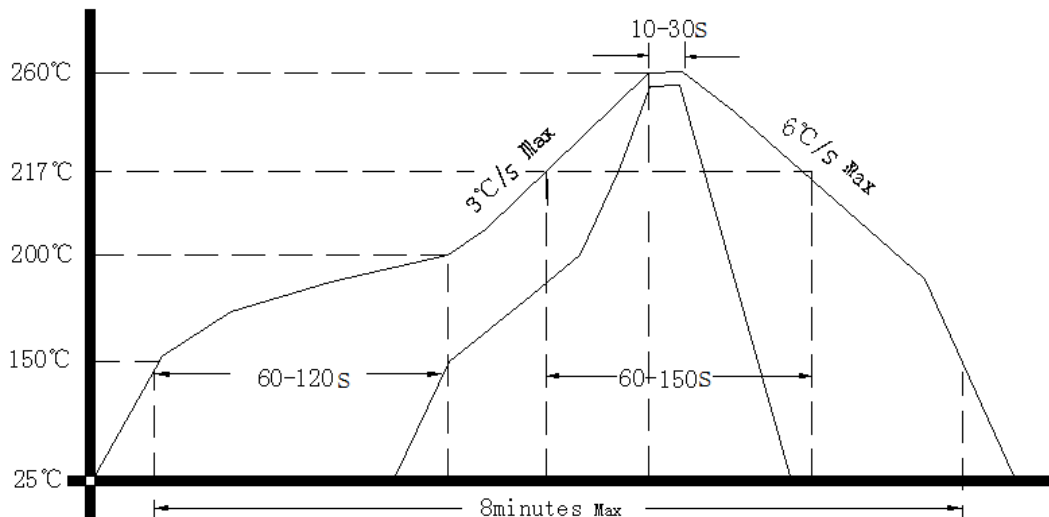



4、 Package: Tape & Reel (mm)

