

Customer Code : \_\_\_\_\_

# DATASHEET

DAPU P/N :           **O23L-L346-10.00MHz-A**          

Customer P/N: \_\_\_\_\_

DAPU			Customer Approval
Drew	Audited	Approved	Stamp, please! Thanks!
Date: 2015.03.05			

## Guangdong Dapu Telecom Technology Co.,Ltd

Bldg13-16,.N.Ind.Zone,SSL Industry Park, Dongguan City, Guangdong Province, China





## 1. Electrical Parameters

MODEL: O23L-L346-10.00MHZ-A						
Item	Description	Parameters			Unit	Test Condition
		Min.	Typ.	Max.		
Output	Frequency	10.00			MHz	
	Output Waveform	HCMOS				
	Output Low Voltage			0.4	V	$V_{cc}=12.0V, O_{load}=15pF$
	Output High Voltage	2.7			V	$V_{cc}=12.0V, O_{load}=15pF$
	Duty Cycle	45	50	55	%	@50%
	Rise / Fall Time (10%~90%)			10	ns	
	Load	15			pF	
	Spurious Suppression			-70	dBc	
Frequency Stabilities	Frequency Tolerance vs. Operating Temperature Range		-3	+3	$\times 10^{-9}$	$T_A$ varied from $-10^{\circ}C$ to $70^{\circ}C$ , measurement referenced to frequency observed with $f_{ref}=(f_{max}+f_{min})/2, V_{cc}=12.0V, V_c=2.5V, O_{load}=15pF$ , temperature variable speed less than $2^{\circ}C$ per minute.
			-0.015	+0.015	$\times 10^{-6}$	$T_A$ varied from $-40^{\circ}C$ to $75^{\circ}C$ , measurement referenced to frequency observed with $f_{ref}=(f_{max}+f_{min})/2, V_{cc}=12.0V, V_c=2.5V, O_{load}=15pF$ , temperature variable speed less than $2^{\circ}C$ per minute.
	Initial Frequency Tolerance		-0.05	+0.05	$\times 10^{-6}$	Measurement referenced to frequency observed with $T_A=25^{\circ}C, V_{cc}=12.0V, V_c=2.5V$ , and after 30 minutes of operation, within 90 days after ex-works.
	Frequency Tolerance vs. Supply Voltage		-0.3	+0.3	$\times 10^{-9}$	measurement referenced to frequency observed $T_A=25^{\circ}C, V_{cc}$ varied from 11.4V to 12.6V, $V_c=2.5V$ and $O_{Load}=15pF$ .
	Frequency Tolerance vs. Load		-0.3	+0.3	$\times 10^{-9}$	10% load change measurement referenced to frequency observed with $T_A=25^{\circ}C, V_{cc}=12.0V, V_c=2.5V$ , and $O_{Load}=15pF$ .
	Short-Term Stability: Allan Variance			0.01	$\times 10^{-9}$	Temperature stability, no EMI\EMC or other interference, test after power for 1hour ref. to $25^{\circ}C$ ; 1s, using PN9000 equipment.
	Day Drift		-2	+2	$\times 10^{-9}$	After 14 days operation, for aging, $\pm 5\%$ voltage change, and $\pm 10^{\circ}C$ temperature change.



	Aging Tolerance Per Day	-0.3		+0.3	$\times 10^{-9}$	$V_{cc}, V_c, T_A$ constant measurement referenced to frequency observed with $T_A=25^\circ C, V_{cc}=12.0V, V_c=2.5V$ , and after 30 days of operation.
	Aging Tolerance 1 Year	-0.05		+0.05	$\times 10^{-6}$	
	Aging Tolerance 10 Years	-0.35		+0.35	$\times 10^{-6}$	
	Retrace	-5		+5	$\times 10^{-9}$	After 120 minutes from turn on, following 24 hours minimum on time, and 24 hours maximum off time. At constant temperature and voltage. Referenced to frequency at off time.
Power Supply	Supply Voltage	11.4	12.0	12.6	V	
	Steady Consumption			200	mA	@25°C
	Warm up current			350	mA	
	Warm-up Time			8	minutes	@25°C within $\pm 0.05 \times 10^{-6}$ of final frequency with reference after 1 hour on.
Voltage Control Characteristics	Frequency Tuning Range	-0.8		-0.4	$\times 10^{-6}$	$V_c=0V$ . measurement referenced to $V_c=2.5V$
		-0.05		+0.05	$\times 10^{-6}$	$V_c=2.5V$ . measurement referenced to exactly 10.00MHz
		+0.4		+0.8	$\times 10^{-6}$	$V_c=5.0V$ . measurement referenced to $V_c=2.5V$
	Linearity			10	%	
	Slope	Positive				
	Input Impedance	100			K $\Omega$	
Phase Noise	Phase Noise @25°C		-90	-85	dBc/Hz	1Hz
			-125	-120		10Hz
			-145	-140		100Hz
			-155	-150		1KHz
			-155	-150		10KHz
			-155	-150		100KHz
			-155	-150		



Environmental Conditions	Operable Temperature	-40		+85	°C	
	Storage Temperature	-55		+105	°C	
	ESD Level	Human Body Model, class2: 2000V to 4000V; ANSI/ESDA/JEDEC JS-001-2010.				
		Machine Model, class B: 200V to 400V; ANSI/ESDA/JEDEC JS-001-2010.				
	Moisture Sensitivity Level	Not humidity sensitive.				
	Vibration	Test Condition: 0.75mm ;acceleration:10g;10Hz~500Hz, one cycle per 30 min, test 2 hour. (3 times for each 3 directions X , Y , Z), IEC 68-2-06 Test Fc.				
Shock	50g; 11ms; half sine wave (3 times for each 3 directions X, Y, Z), IEC 68-2-27 Test Ea/Severity 50A.					
Full Package Storage	Relative Humidity (%)	20% ~ 70%				
	Temperature (°C)	-10~35°C				

DAPU Confidential



## 2. Mechanical Structure (mm)

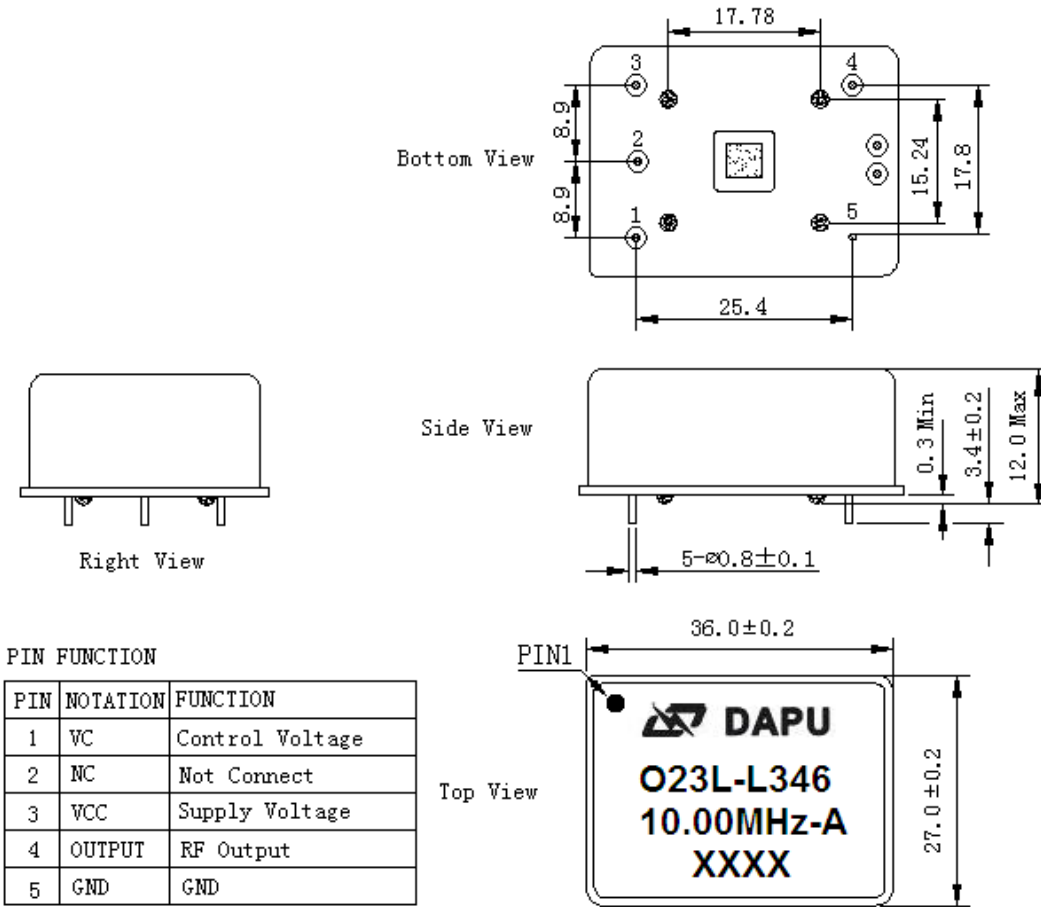

### PIN FUNCTION

PIN	NOTATION	FUNCTION
1	VC	Control Voltage
2	NC	Not Connect
3	VCC	Supply Voltage
4	OUTPUT	RF Output
5	GND	GND

- Note1:** Tolerance ±0.2mm without mark
- Note2:** The first two xx representative: week  
After two xx representative: year
- Note3:** Referential Weight 19.0g
- Note4:** NC is not connect

## 4. Test Circuit

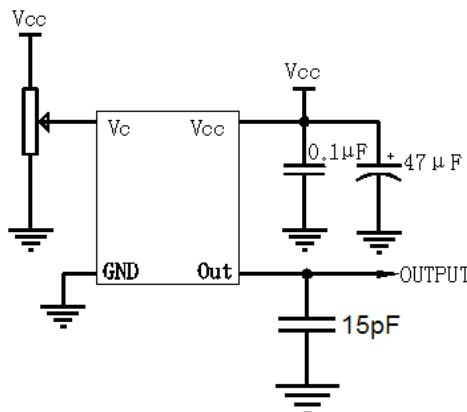



### 5. Reflow Soldering Curve (RoHS)

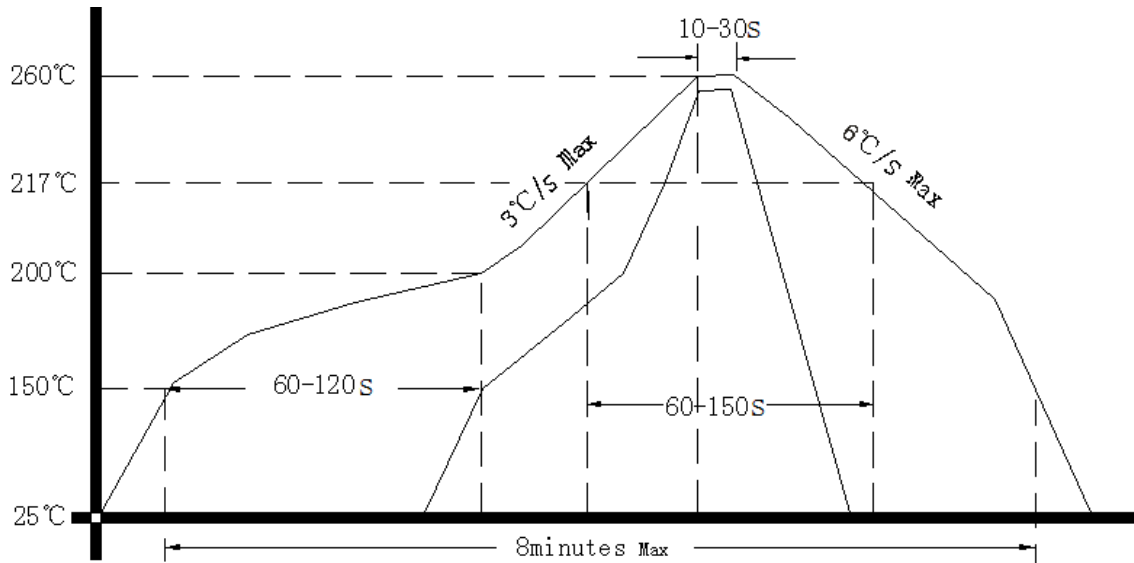

### 6. Package (mm)

