

Travelling Merchant: \_\_\_\_\_

# DATASHEET

Standard:           **V756-B314-25.00MHz**          

P/N: \_\_\_\_\_

Plot			The Label
Drew	Audited	Approved	Stamp, please! Thanks!
Date: 2012.06.06			

**Guangdong Dapu Telecom Technology Co.,Ltd**

Bldg13-16,.N.Ind.Zone,SSL Industry Park, Dongguan City, Guangdong Province, China

TEL: 0086-0769-88010888 FAX: 0086-0769-81800098





## 1. Electrical Parameters

MODEL: V756-B314-25.00MHZ						
Item	Description	Parameters			Unit	Test Condition
		Min.	Typ.	Max.		
Output	Frequency	25.00			MHz	
	Output Waveform	HCMOS				
	Output Low Voltage			0.33	V	$V_{cc}=3.3V, O_{load}=15\text{ pF}$
	Output High Voltage	2.97			V	$V_{cc}=3.3V, O_{load}=15\text{ pF}$
	Duty Cycle	45	50	55	%	@50%
	Rise / Fall Time (10%~90%)			5	ns	@25°C
	Load	15			pF	
Frequency Stabilities	Frequency Tolerance vs. Operating Temperature Range	-30		+30	$\times 10^{-6}$	$T_A$ varied from -40°C to 85°C, measurement referenced to frequency observed with $T_A = 25^\circ\text{C}$ , $V_{cc}=3.3V$ , $V_c=1.65V$ , $O_{load}=15\text{pF}$ , temperature variable speed less than 2°C per minute.
	Initial Frequency Tolerance	-15		+15	$\times 10^{-6}$	Measurement referenced to frequency observed with $T_A=25^\circ\text{C}$ , $V_{cc}=3.3V$ , $V_c=1.65V$ within 30 days after ex-works.
	Frequency Tolerance vs. Supply Voltage	-5		+5	$\times 10^{-6}$	measurement referenced to frequency observed $T_A=25^\circ\text{C}$ , $V_{cc}$ varied from 3.13V to 3.47V, $V_c=1.65V$ and $O_{Load}=15\text{pF}$ .
	Frequency Tolerance vs. Load	-3		+3	$\times 10^{-6}$	5% load change measurement referenced to frequency observed with $T_A=25^\circ\text{C}$ , $V_{cc}=3.3V$ , $V_c=1.65V$ , $O_{Load}=15\text{pF}$
	Aging Tolerance 1 Year	-5		+5	$\times 10^{-6}$	$T_A=25^\circ\text{C}$ , $V_{cc}=3.3V$ , $V_c=1.65V$ and after 1h of operation.
Power Supply	Current Consumption			20	mA	@25°C, $V_{cc}=3.3V$ , $V_c=1.65V$ , $O_{load}=15\text{pF}$ .
	Supply Voltage	3.13	3.3	3.47	V	



Voltage Control Characteristics	Frequency Tuning Range	-200		-75	$\times 10^{-6}$	$V_c=0V$ . measurement referenced to $V_c=1.65V$
		-15		+15	$\times 10^{-6}$	$V_c=1.65V$ . measurement referenced to exactly 25.00MHz
		+75		+200	$\times 10^{-6}$	$V_c=3.3V$ . measurement referenced to $V_c=1.65V$
	Linearity			10	%	
	Slope	Positive				
	Input Impedance	1				M $\Omega$
Phase Noise	Phase Noise		-70	-65	dBc/Hz	10Hz
			-100	-95		100Hz
			-130	-125		1KHz
			-145	-140		10KHz
			-150	-145		100KHz
			-155	-150		1MHz
Environmental Conditions	Operable Temperature	-40		+85	$^{\circ}C$	
	Storage Temperature	-55		+105	$^{\circ}C$	
	ESD Level	Human Body Model, class2: 2000V to 4000V; ANSI/ESDA/JEDEC JS-001-2010.				
		Machine Model, class B: 200V to 400V; ANSI/ESDA/JEDEC JS-001-2010.				
	Moisture Sensitivity Level	Level 2.				
	Vibration	Test Condition: 0.75mm; acceleration:10g;10Hz~2000Hz, one cycle per 30 min, test 2 hour. (3 times for each 3 directions X , Y , Z) .IEC 68-2-06 Test Fc.				
Shock	100g; 6ms; half sine wave (3 times for each 3 directions X , Y , Z ),IEC 68-2-27 Test Ea/Severity 50A.					



## 2. Mechanical Structure(mm)

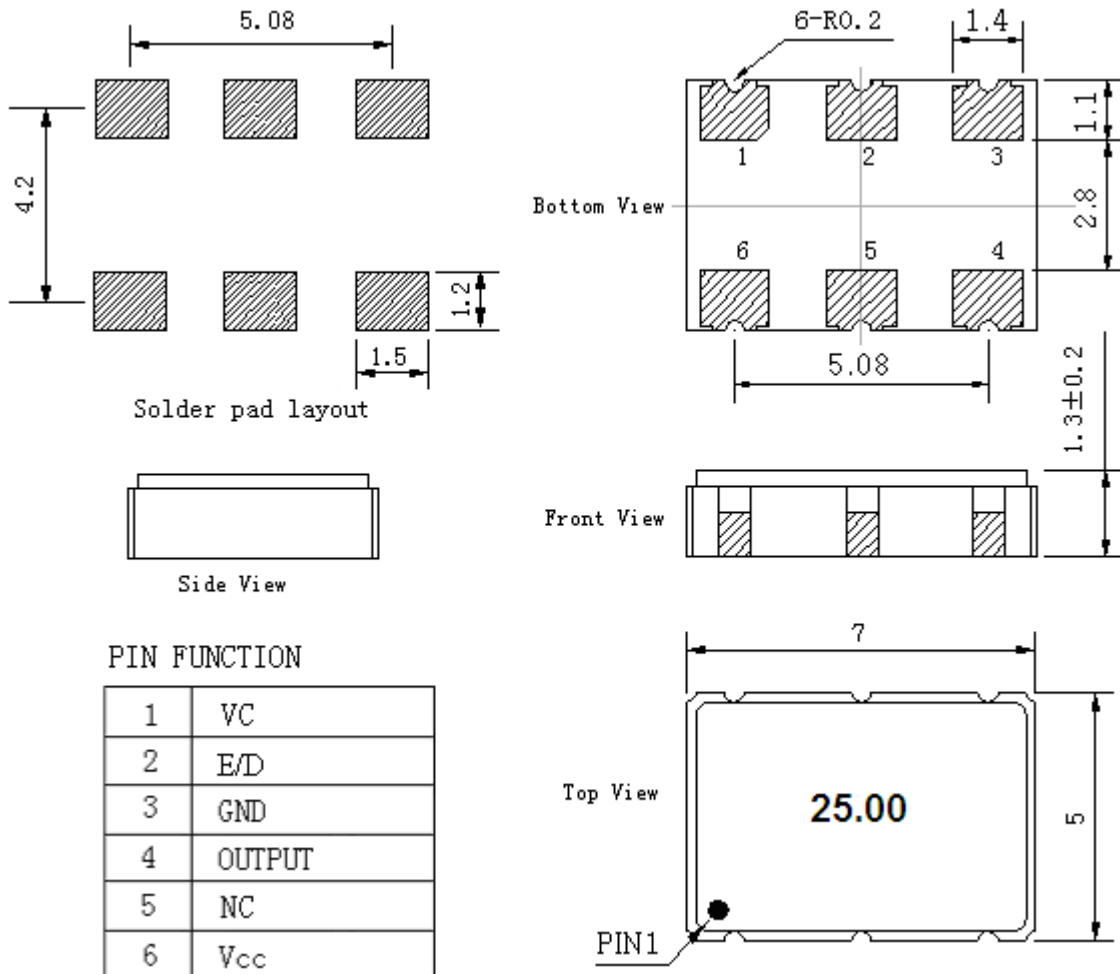

**Note1:** Tolerance ±0.1mm without mark

**Note2:** Referential Weight 0.2g

**Note3:** Disable:  $V_{il} \leq V_{cc} - 2.0V$

Enable:  $V_{ih} \geq V_{cc} - 1.025V$

E/D	OUT
high level, open	data
low level	no data



### 3. Test circuit

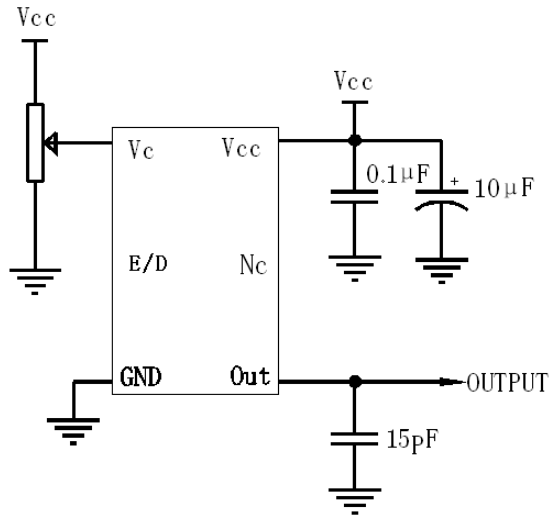

### 4. Reflow Soldering Curve (RoHS)

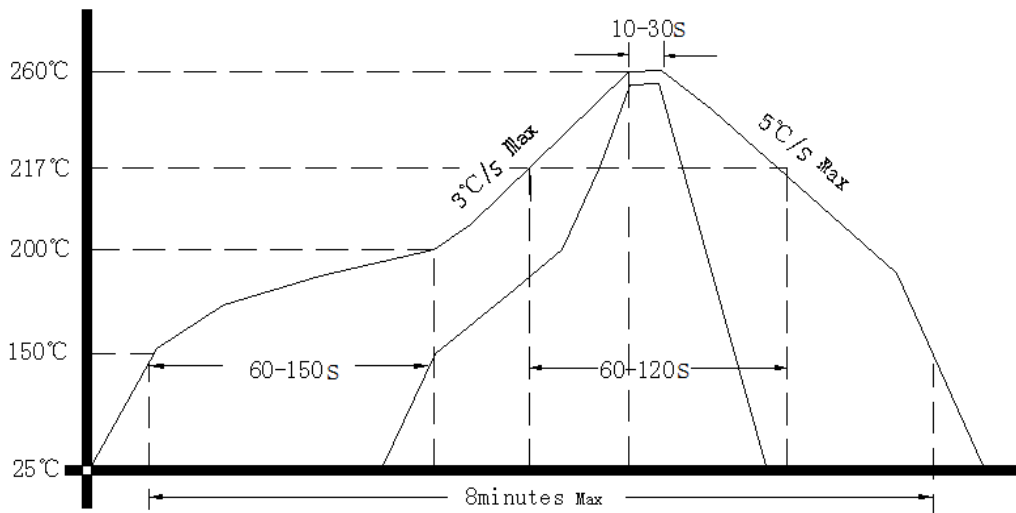

### 5. Package: Tape & Reel (mm)

