

Travelling Merchant: _____

DATASHEET

Standard: **DP6P32770001**

JSX1A3276802

Plot			The Label
Drew	Audited	Approved	Stamp, please! Thanks!
Date: 2015.03.30			

Guangdong Dapu Telecom Technology Co.,LTD

Bldg13-16,.N.Ind.Zone,SSL Industry Park, Dongguan City, Guangdong Province, China

TEL: 0086-0769-88010888 FAX: 0086-0769-81800098



1、 Electrical Parameters

MODEL: DP6P32770001							
No.	Parameters	SYM.	Electrical Spec.				Notes
			Min.	Typ.	Max.	Units	
1	Nominal Frequency	FL	32.768			KHz	
2	Oscillation Mode	-	Fundamental			-	
3	Load Capacitance	CL	12.5			pF	
4	Frequency Tolerance	-	-20	-	+20	$\times 10^{-6}$	at 25°C±5°C
5	Frequency-Temperature Coefficient	B	-	-	-0.04	$\times 10^{-6}/^{\circ}\text{C}^2$	
6	Operating Temperature	-	-40	~	+85	°C	
7	Storage Temperature Range	-	-55	~	+125	°C	
8	Aging	-	-3	-	+3	$\times 10^{-6}$	1st Year
9	Drive Level	DL	-	-	1.0	uW	
10	Effective Resistance R1	R1	-	-	65	KΩ	
11	Motional Capacitance C1	-	-	1.9	-	fF	
12	Shunt Capacitance C0	C0	-	0.8	-	pF	
13	Insulation Resistance	-	500	-	-	MΩ	at DC 100V
14	ESD Level	Human Body Model,class2: 2000V to 4000V; ANSI/ESDA/JEDEC JS-001-2010					
		Machine Model, class B: 200V to 400V; ANSI/ESDA/JEDEC JS-001-2010					
15	Moisture Sensitivity Level	Level 2					
16	Vibration	Test Condition: 0.75mm ;acceleration:10g;10Hz~2000Hz, one cycle per 30 min, test 2 hour. (3 times for each 3 directions X ,Y , Z). IEC 68-2-06 Test Fc.					
17	Shock	100g; 6ms; half sine wave (3 times for each 3 directions X ,Y , Z),IEC 68-2-27 Test Ea/Severity 50A.					



2、Mechanical Structure(mm)

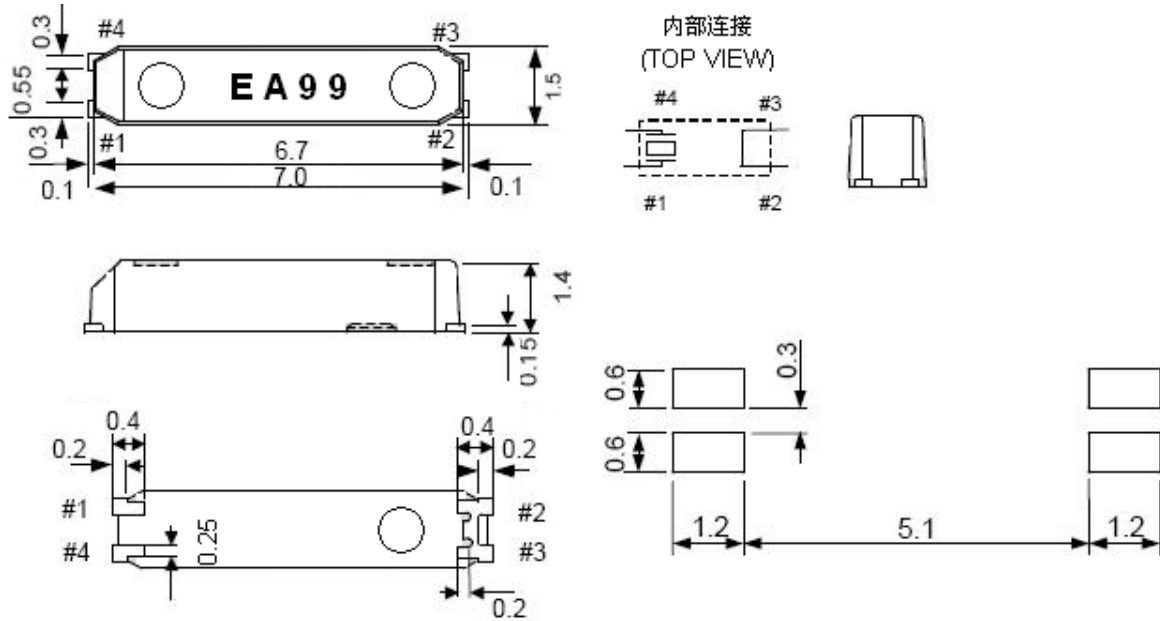

Note1: Tolerance ± 0.2 mm

Note2: 请勿连接#2 与#3 到处部器件

在该产品顶部或底部可能暴露着金属材料，但这不影响任何规格性能

3、Reflow Soldering Curve (RoHS)

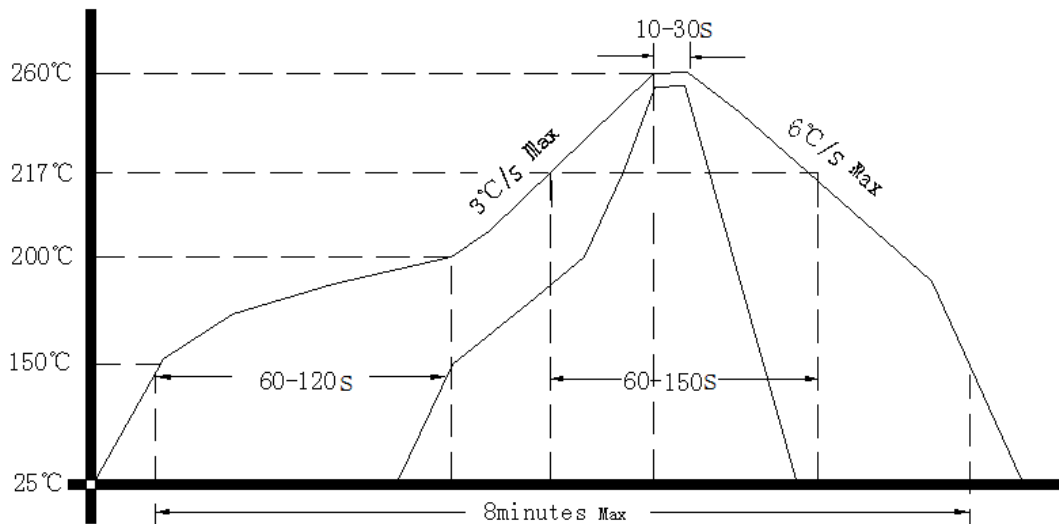



4、 Package: Tape & Reel (mm)

