

Travelling Merchant: _____

DATASHEET

Standard: V756-D315-89.60MHzP/N: Z75ZCYS89601

Plot			The Label
Drew	Audited	Approved	Stamp, please! Thanks!
Date: 2014.10.17			

Guangdong Dapu Telecom Technology Co.,Ltd

Bldg13-16,.N.Ind.Zone,SSL Industry Park, Dongguan City, Guangdong Province, China

TEL: 0086-0769-88010888 FAX: 0086-0769-81800098

**1、 Electrical Parameters**

Parameters	SYM	Electrical Spec.				Notes
		Min.	Typ.	Max.	Units	
Frequency Stabilities						
Nominal Frequency	F _N	89.60			MHz	
Overall Stability		-50		+50	× 10 ⁻⁶	
Vs. aging /1.year		-2		+2	× 10 ⁻⁶	@25°C, V _C =1.65V, V _{CC} =3.3V, Load=15 pF
RF Output						
Output Waveform		HCMOS				
Load	I _{OUT}	15			pF	
Output Voltage High	V _{OH}	2.97			V	
Output Voltage Low	V _{OL}			0.33	V	
Rise / Fall Time	T _r / T _f			3	ns	10%-90%
Symmetry	SYM	45	~	55	%	@50%
Start-up Time	T _S			10	ms	
Supply Voltage						
Supply Voltage	V _{CC}	3.13	3.3	3.47	V	
Input Current	I _{CC}			20	mA	
Control Voltage						
Control Voltage Rang	V _C	0.3		3.0	V	V _C =1.65V
Frequency Tuning Range	PR	±100			× 10 ⁻⁶	
Linearity	Lin			10	%	
Slope		Positive				
Enable Control		Yes				Pad 2
Output Enable	V _{IH}	2.97			V	
Output Disable	V _{IL}			0.33	V	
Phase Noise						
Jitter				0.9	ps	RMS(12KHz to 20MHz)
Phase Noise			-57		dBc/Hz	10Hz
			-94			100Hz
			-114			1KHz
			-123			10KHz
			-124			100KHz
			-144			1MHz
			-152			10MHz



Environmental Conditions						
Operating Temperature	T _{OP}	-20	~	70	°C	
Storage Temperature	T _{ST}	-55	~	125	°C	
ESD Level	Human Body Model, class2: 2000V to 4000V; ANSI/ESDA/JEDEC JS-001-2010.					
	Machine Model, class B: 200V to 400V; ANSI/ESDA/JEDEC JS-001-2010.					
Moisture Sensitivity Level	Level 2.					
Vibration	Test Condition: 0.75mm; acceleration:10g;10Hz~2000Hz, one cycle per 30 min, test 2 hour. (3 times for each 3 directions X ,Y , Z) .IEC 68-2-06 Test Fc.					
Shock	100g; 6ms; half sine wave (3 times for each 3 directions X ,Y, Z),IEC 68-2-27 Test Ea/Severity 50A.					

DAPU Confidential FOR 新华三信息技术有限公司



2、 Mechanical Structure(mm)

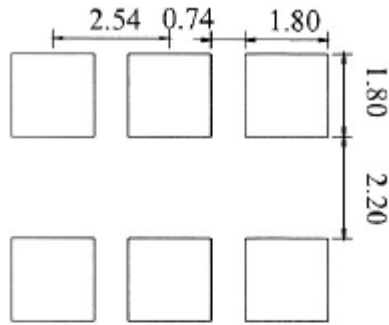

Solder pad layout

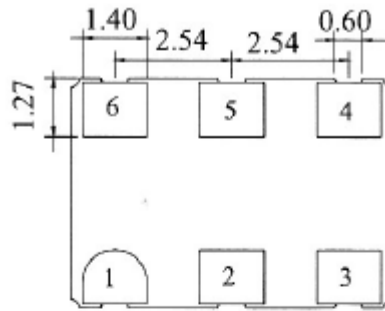

Top view

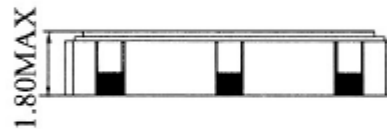

Side view

PIN FUNCTION

PIN	FUNCTION
1	VC
2	E/D
3	GND
4	OUTPUT
5	NC
6	VCC

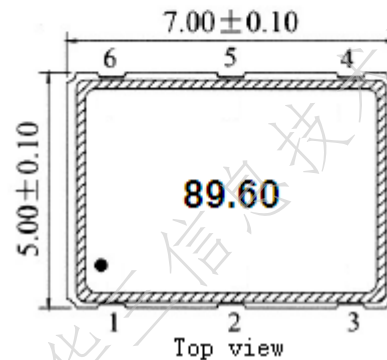

Top view

Note1: Tolerance $\pm 0.1\text{mm}$ without mark

Note2: Referential Weight 0.3g

Note3: NC is not connect

Note4: Disable: $V_{il} \leq 0.33\text{V}$

Enable: $V_{ih} \geq 2.97\text{V}$

E/D	OUT
high level, open	data
low level	no data



3、 Test circuit

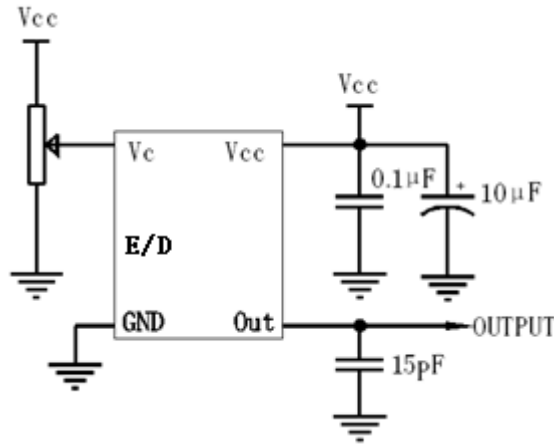

4、 Reflow Soldering Curve (RoHS)

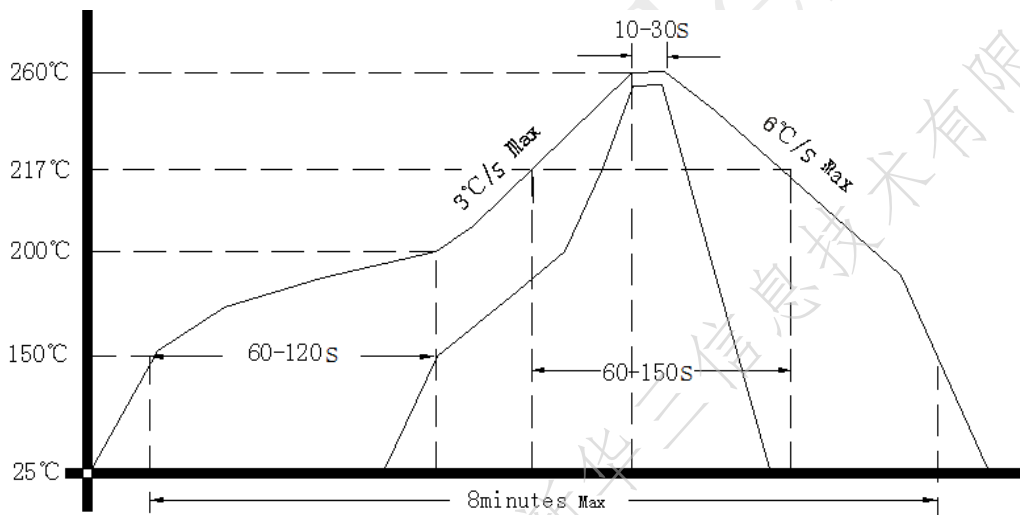

5、 Package: Tape & Reel (mm)

