

Travelling Merchant: _____

DATASHEET

Standard: DP7XZ32770004

Plot			The Label
Drew	Audited	Approved	Stamp, please! Thanks!
Date: 2009.03.08			

Guangdong Dapu Telecom Technology Co.,Ltd

Bldg13-16,.N.Ind.Zone,SSL Industry Park, Dongguan City, Guangdong Province, China

TEL: 0086-0769-88010888 FAX: 0086-0769-81800098



1、 Electrical Parameters

MODEL: DP7XZ32770004							
No.	Parameters	SYM.	Electrical Spec.				Notes
			Min.	Typ.	Max.	Units	
1	Nominal Frequency	FL	32.768			KHz	
2	Output Waveform	-	HCMOS				
3	Supply Voltage	Vcc	2.97	3.3	3.63	V	
4	Rise/Fall Time (10%~90%)	-	-	-	5	nS	
5	Output Load	-	15pF			-	
6	Frequency Stability	-	-50	-	+50	$\times 10^{-6}$	
7	Operating Temperature Range	-	-40	~	+85	°C	
8	Storage Temperature	-	-55	~	+125	°C	
9	Input Current	Icc	-	-	8	mA	
10	Symmetry (Duty ratio)	-	40	~	60	%	
11	Start Time	-	-	-	10	mS	
12	Output Voltage High	VoH	90%	-	-	V _{DD}	
13	Output Voltage Low	Vol	-	-	10%	V _{DD}	
14	Enable Voltage High	Vhi	0.8V _{DD}	-	-	V	
15	Disable Voltage Low	Vlo	-	-	0.3V _{DD}	V	
16	Aging	-	-2	~	+2	$\times 10^{-6}$	1st Year
17	ESD Level	Human Body Model,class2: 2000V to 4000V; ANSI/ESDA/JEDEC JS-001-2010.					
		Machine Model, class B: 200V to 400V; ANSI/ESDA/JEDEC JS-001-2010.					
18	Moisture Sensitivity Level	Level 2.					
19	Vibration	Test Condition: 0.75mm ;acceleration:10g;10Hz~2000Hz, one cycle per 30 min, test 2 hour. (3 times for each 3 directions X ,Y , Z) .IEC 68-2-06 Test Fc.					
20	Shock	100g; 6ms; half sine wave (3 times for each 3 directions X ,Y , Z),IEC 68-2-27 Test Ea/Severity 50A.					



2、Mechanical Structure(mm)

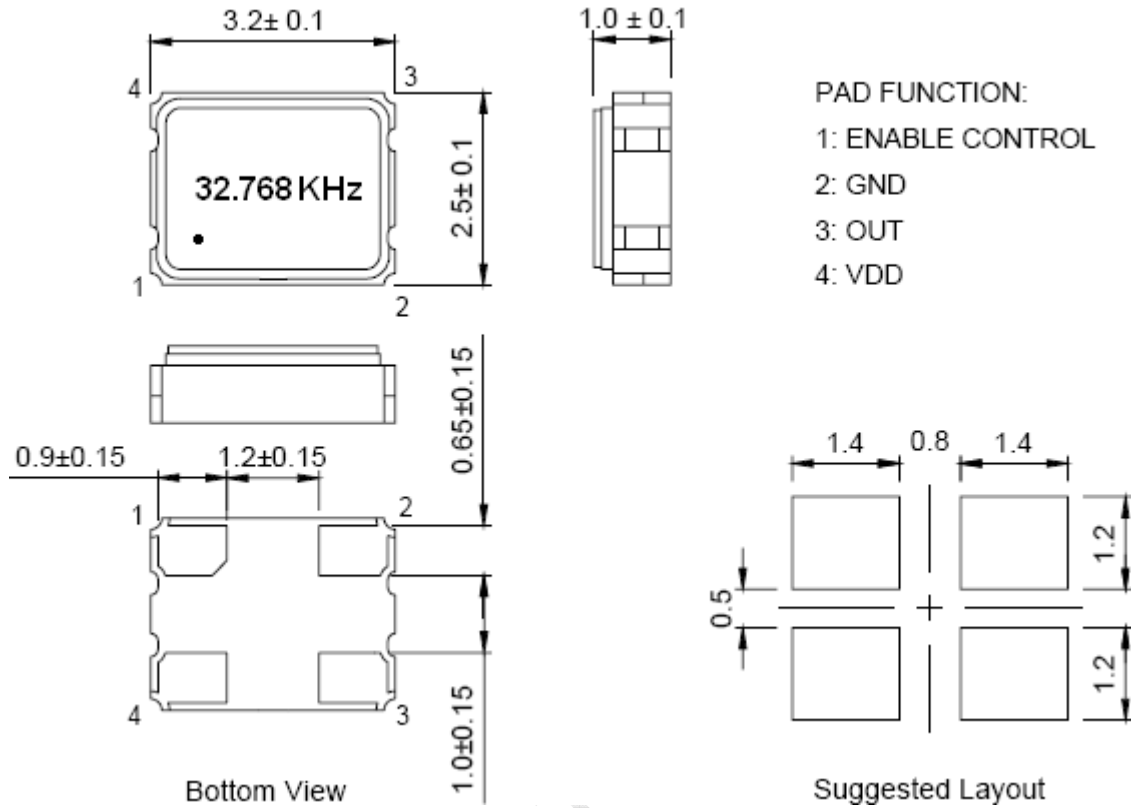

Note1: Tolerance $\pm 0.1\text{mm}$ without mark

3、Test Diagram

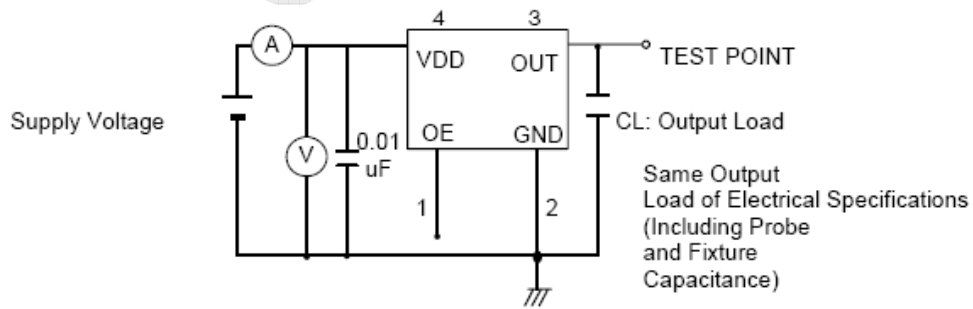

Control input (output enable/disable)
 Logic 1 or open on pad 1: Oscillator output
 Logic 0 on pad 1 : Disable output to high impedance



4、 Reflow Soldering Curve (RoHS)

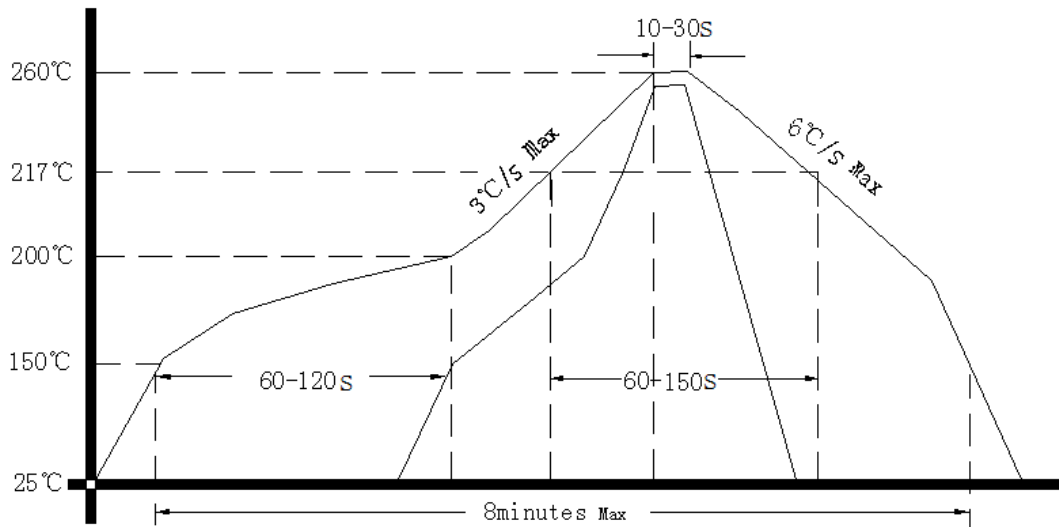

5、 Package: Tape & Reel (mm)

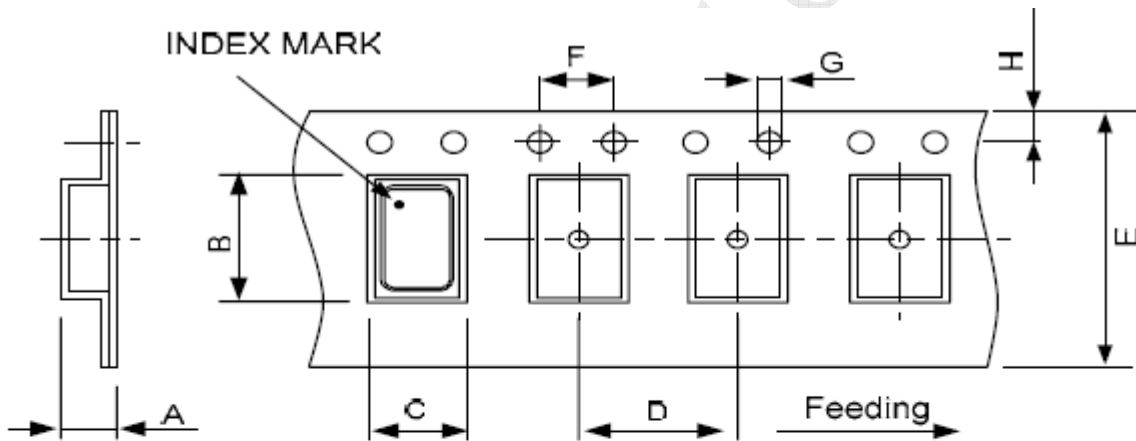

DIMENSIONS	A	B	C	D	E	F	G	H	(UNIT : mm)
		2.30	7.90	5.45	8.00	16.00	4.00	1.50	

REMARK :

