



1. Electrical Parameters

MODEL: T53-2101-19.20MHz						
Item	Description	Parameters			Unit	Test Condition
		Min.	Typ.	Max.		
Output	Frequency	19.20			MHz	
	Output Waveform	HCMOS				
	Output Low Voltage			0.4	V	$V_{cc}=3.3V, O_{load}=15\text{ pF}$
	Output High Voltage	2.4			V	$V_{cc}=3.3V, O_{load}=15\text{ pF}$
	Duty Cycle	45	50	55	%	@50%
	Rise / Fall Time (10%~90%)			8	ns	@25°C
	Load	15			pF	
	Jitter			1.7	ps	Frequency offset from carrier 10Hz to 1MHz
Frequency Stabilities	Frequency Tolerance vs. Operating Temperature Range	-0.1		+0.1	$\times 10^{-6}$	T_A varied from 0°C to 70°C, measurement referenced to frequency observed with $T_A = 25^\circ\text{C}$, $V_{cc}=3.3V, V_c=1.5V, O_{load}=15\text{ pF}$, temperature variable speed less than 2°C per minute
		-0.25		+0.25	$\times 10^{-6}$ 文本	T_A varied from -20°C to 70°C, measurement referenced to frequency observed with $T_A = 25^\circ\text{C}$, $V_{cc}=3.3V, V_c=1.5V, O_{load}=15\text{ pF}$, temperature variable speed less than 2°C per minute
	Nominal Frequency Tolerance	-2		+2	$\times 10^{-6}$	Measurement referenced to frequency observed with $T_A=25^\circ\text{C}$, $V_{cc}=3.3V, V_c=1.5V$, 1 hour after reflow
	Temperature rate of change			1	°C/min	Maximum rate of change of temperature
	Frequency Tolerance vs. Supply Voltage		± 0.01		$\times 10^{-6}$	measurement referenced to frequency observed $T_A=25^\circ\text{C}$, V_{cc} varied from 3.23V to 3.37V, $V_c=1.5V$ and $O_{Load}=15\text{ pF}$
	Frequency Tolerance vs. Load		± 0.015		$\times 10^{-6}$	2% load change measurement referenced to frequency observed with $T_A=25^\circ\text{C}$, $V_{cc}=3.3V, V_c=1.5V, O_{Load}=15\text{ pF}$
	Aging Tolerance Per Day	-0.02		+0.02	$\times 10^{-6}$	$T_A=25^\circ\text{C}$, $V_{cc}=3.3V, V_c=1.5V$ and after 1h of operation
	Aging Tolerance 1 Month	-0.2		+0.2	$\times 10^{-6}$	
	Aging Tolerance 1 Year	-1		+1	$\times 10^{-6}$	



	Aging Tolerance 3 Years	-2		+2	$\times 10^{-6}$	$T_A=25^{\circ}\text{C}$, $V_{cc}=3.3\text{V}$, $V_c=1.5\text{V}$ and after 1h of operation
Power Supply	Current Consumption			8	mA	@ 25°C , $V_{cc}=3.3\text{V}$, $V_c=1.5\text{V}$, $O_{load}=15\text{pF}$
	Supply Voltage	3.13	3.3	3.47	V	
Voltage Control Characteristics	Frequency Tuning Range	-15		-5	$\times 10^{-6}$	$V_c=0.5\text{V}$. measurement referenced to $V_c=1.5\text{V}$
		-2		+2	$\times 10^{-6}$	$V_c=1.5\text{V}$. measurement referenced to Exactly 19.20MHz
		+5		+15	$\times 10^{-6}$	$V_c=2.5\text{V}$. measurement referenced to $V_c=1.5\text{V}$
	Linearity			10	%	
	Slope	Positive				
	Input Impedance	100				K Ω
Phase Noise	Phase Noise @ 25°C		-55	-50	dBc/Hz	1Hz
			-85	-80		10Hz
			-115	-110		100Hz
			-135	-130		1KHz
			-147	-142		10KHz
			-150	-145		100KHz
			-150	-145		1MHz
Environmental Conditions	Operable Temperature	-20		+70	$^{\circ}\text{C}$	
	Storage Temperature	-55		+105	$^{\circ}\text{C}$	
	ESD Level	Human Body Model,class2: 2000V to 4000V; ANSI/ESDA/JEDEC JS-001-2010.				
		Machine Model, class B: 200V to 400V; ANSI/ESDA/JEDEC JS-001-2010.				
	Moisture Sensitivity Level	Level 2.				
	Vibration	Test Condition: 0.75mm ;acceleration:10g;10Hz~2000Hz, one cycle per 30 min, test 2 hour. (3 times for each 3 directions X , Y , Z) .IEC 68-2-06 Test Fc.				
Shock	100g; 6ms; half sine wave (3 times for each 3 directions X , Y , Z),IEC 68-2-27 Test Ea/Severity 50A.					



2. Mechanical Structure(mm)

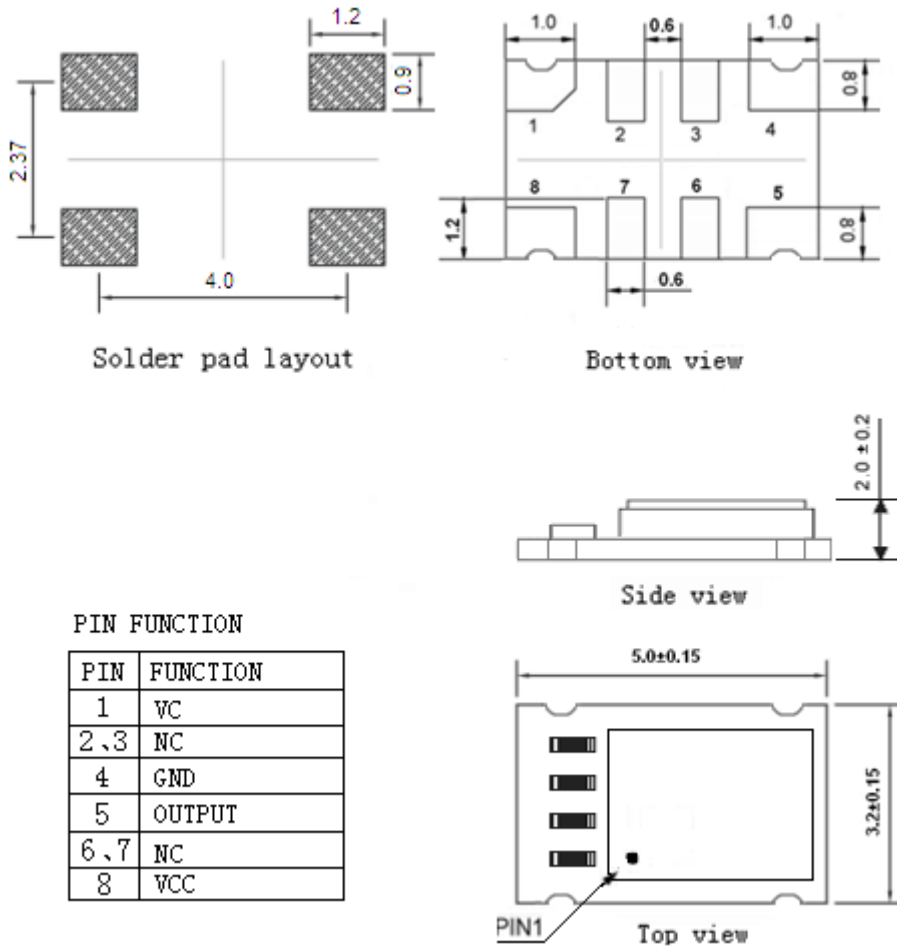

PIN FUNCTION

PIN	FUNCTION
1	VC
2,3	NC
4	GND
5	OUTPUT
6,7	NC
8	VCC

Note1: Tolerance ±0.1mm without mark

Note2: Referential Weight 0.05g

Note3: NC is not connect

Note4: Material composition :

Pad/terminals: Cu (Surface plating: Ni 3-6um, Au 0.1~0.5um)

Base: High-TG FR4

3. Test circuit

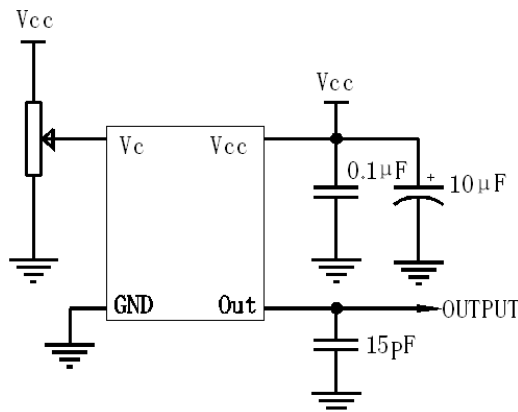



4. Reflow Soldering Curve (RoHS)



5. Package: Tape & Reel (mm)

