

Travelling Merchant: _____

DATASHEET

Standard: DP7W28000001Y75NN28001

Plot			The Label
Drew	Audited	Approved	Stamp, please! Thanks!
Date: 2014.08.06			

Guangdong Dapu Telecom Technology Co.,Ltd

Bldg13-16,.N.Ind.Zone,SSL Industry Park, Dongguan City, Guangdong Province, China

TEL: 0086-0769-88010888 FAX: 0086-0769-81800098



1、Electrical Parameters

MODEL: DP7W28000001							
No.	Parameters	SYM.	Electrical Spec.				Notes
			Min.	Typ.	Max.	Units	
1	Nominal Frequency	FL	28.00			MHz	
2	Mode of Oscillation	OT	Fundamental				
3	Frequency Stability	-	-30	~	+30	$\times 10^{-6}$	incl.25°C tolerance, tolerance over operating temperature range, input voltage change, load change,1 year aging
4	Operating Temperature	Topr	-40	~	+85	°C	
5	Storage Temperature	Tstg	-55	~	+125	°C	
6	Supply Voltage	VDD	3.3±10%			V	
7	Input Current	Icc	-	-	20	mA	
8	Enable Control	-	Yes			-	
9	Output Load:	CL	15			pF	
10	Fan out type	LT	CMOS				
11	Output Voltage High	VoH	90%Vdd	-	-	V	
12	Output Voltage Low	Vol	-	-	10%Vdd	V	
13	Rise Time	Tr	-	-	5	ns	10%-90%VDD Level
14	Fall Time	Tf	-	-	5	ns	90%-10%VDD Level
15	Symmetry (Duty ratio)	TH/T	45	~	55	%	
16	Start-up Time	Tosc	-	-	3	ms	
17	Standby current	-	-	-	10	μA	
18	Enable Voltage High	Vhi	70%Vdd	-	-	V	
19	Disable Voltage Low	Vlo	-	-	30%Vdd	V	
20	Aging	-	±3			$\times 10^{-6}$ /yr.	1st. Year at 25°C
21	ESD Level	Human Body Model,class2: 2000V to 4000V; ANSI/ESDA/JEDEC JS-001-2010.					
		Machine Model, class B: 200V to 400V; ANSI/ESDA/JEDEC JS-001-2010.					
22	Moisture Sensitivity Level	Level 2.					
23	Vibration	Test Condition: 0.75mm ;acceleration:10g;10Hz~2000Hz, one cycle per 30 min, test 2 hour. (3 times for each 3 directions X ,Y , Z) .IEC 68-2-06 Test Fc.					
24	Shock	100g; 6ms; half sine wave (3 times for each 3 directions X ,Y , Z),IEC 68-2-27 Test Ea/Severity 50A.					



2、Mechanical Structure(mm)

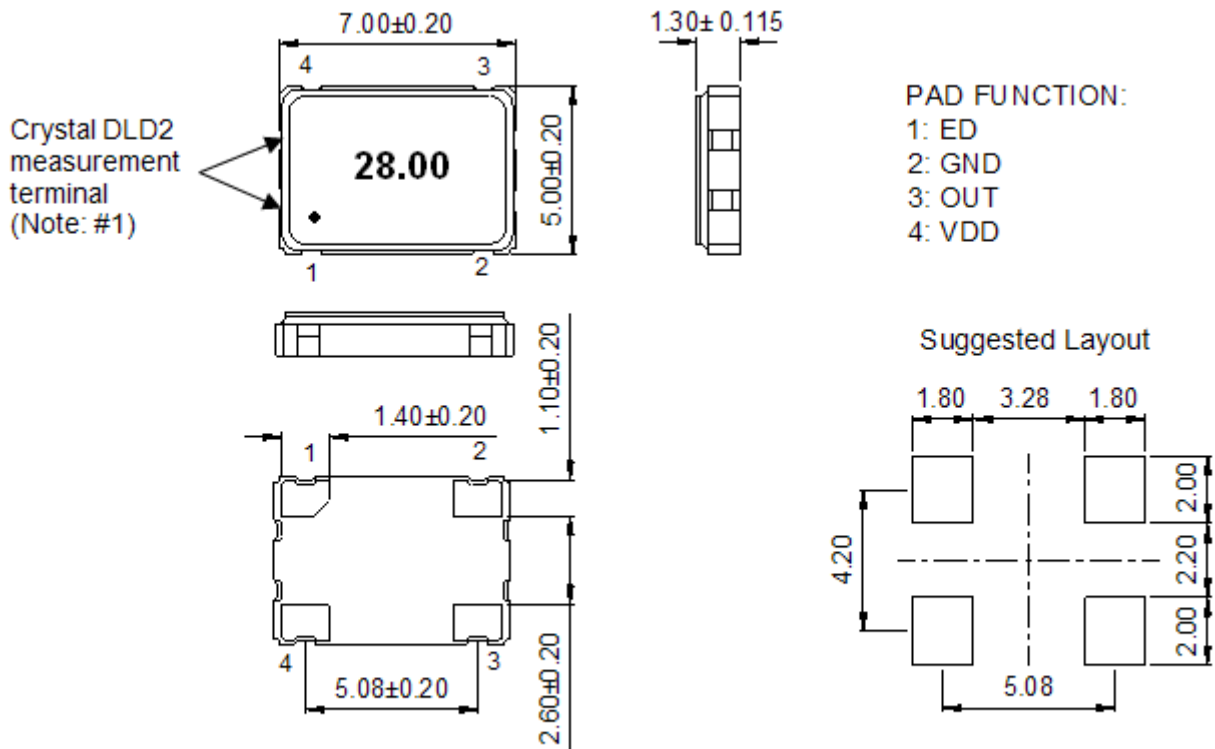

Note: #1. DLD2 / Drive Level Dependency 2 Maximum resistance minus minimum resistance.

3、Test Diagram

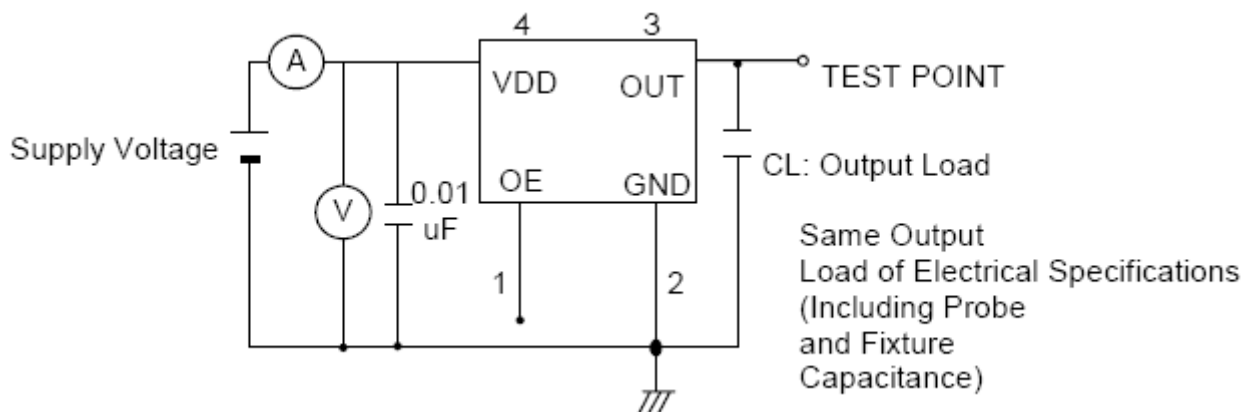

Control input (output enable/disable)

Logic 1 or open on pad 1: Oscillator output

Logic 0 on pad 1 : Disable output to high impedance



4、 Reflow Soldering Curve (RoHS)

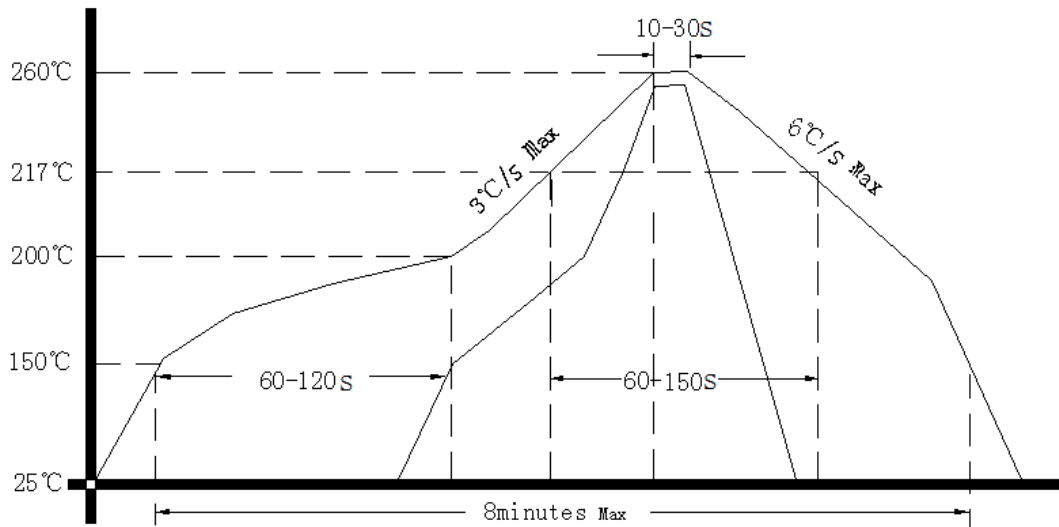

5、 Package: Tape & Reel (mm)

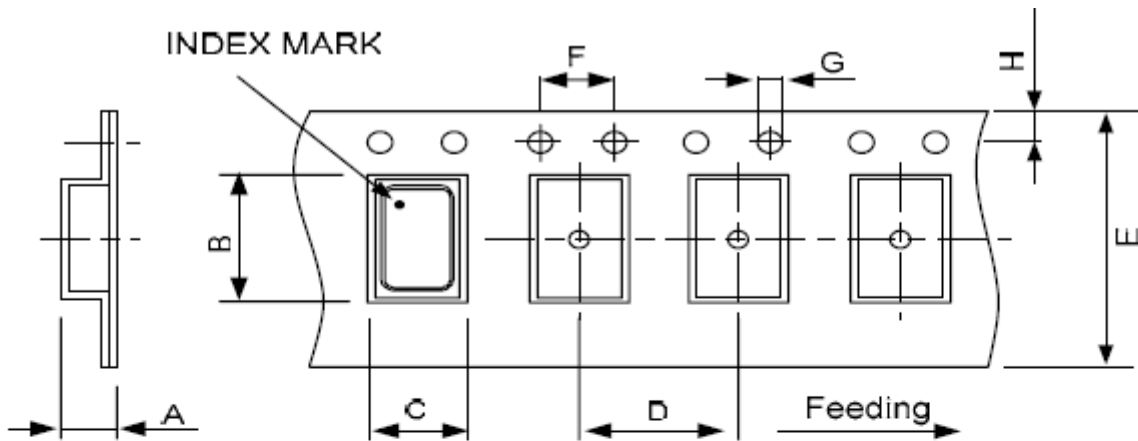

DIMENSIONS	A	B	C	D	E	F	G	H	(UNIT : mm)
	2.30	7.90	5.45	8.00	16.00	4.00	1.50	1.75	

REMARK :

