

Travelling Merchant: _____

DATASHEET

Standard: V53-B311-76.80MHz

Plot			The Label
Drew	Audited	Approved	Stamp, please! Thanks!
Date: _____			

Guangdong Dapu Telecom Technology Co.,Ltd

Bldg13,.N.Ind.Zone,SSL Industry Park, Dongguan City, Guangdong Province, China

TEL: 0086-0769-88010888 FAX: 0086-0769-81800098



1. Electrical Parameters

MODEL: V53-B311-76.80MHz						
Item	Description	Parameters			Unit	Test Condition
		Min.	Typ.	Max.		
Output	Frequency	76.80			MHz	
	Output Waveform	HCMOS				
	Output Low Voltage			0.4	V	V _{cc} =3.3 V, O _{load} =15pF
	Output High Voltage	2.7			V	V _{cc} =3.3V, O _{load} =15pF
	Duty Cycle	45	50	55	%	
	Rise / Fall Time			5	ns	10%~90%
	Load	15			pF	
Frequency Stabilities	Frequency Tolerance vs. Operating Temperature Range	-30		+30	ppm	T _A varied from -40°C to 85°C, measurement referenced to frequency observed with T _A =25°C, V _{cc} =3.3V, V _C =1.65V, O _{load} =15pF, temperature rise speed less than 2°C per minute.
	Initial Frequency Tolerance	-15		+15	ppm	Measurement referenced to frequency observed with T _A =25°C, V _{cc} =3.3V, V _C =1.65V, and after 15 minutes of operation, within 30 days after ex-works.
	Frequency Tolerance vs. Supply Voltage	-3		+3	ppm	measurement referenced to frequency observed T _A =25°C, V _{cc} varied from 3.13V to 3.47V, V _C =1.65V and O _{Load} =15pF.
	Frequency Tolerance vs. Load	-1		+1	ppm	5% load change measurement referenced to frequency observed with T _A =25°C, V _{cc} =3.3V, V _C =1.65V.
	Aging Tolerance 1 Year	-3		+3	ppm	V _{cc} , V _C , T _A constant measurement referenced to frequency observed with T _A =25°C, V _{cc} =3.3V, V _C =1.65V, and after 30 days of operation.
Power Supply	Current Consumption		5		mA	@25°C
	Supply Voltage	+3.13	+3.3	+3.47	V	
Voltage Control Characteristics	Frequency Tuning Range	-150		-60	ppm	V _C =0V. measurement referenced to V _C =1.65V
		-15		+15	ppm	V _C =1.65V. measurement referenced to exactly 76.80MHz
		+60		+150	ppm	V _C =3.3V. measurement referenced to V _C =1.65V



	Linearity			20	%	
	Slope	Positive				
	Input Impedance	100			K Ω	
Phase Noise	Phase Noise		-65		dBc/Hz	10Hz
			-100			100Hz
			-125			1KHz
			-145			10KHz
			-150			100KHz
			-160			1MHz
Environmental Conditions	Operable Temperature	-40		+85	°C	
	Storage Temperature	-55		+125	°C	
	Vibration	Test Condition: 0.75mm ;acceleration:10g;10Hz~2000Hz, one cycle per 30 min, test 2 hour. (3 times for each 3 directions X , Y , Z).				
	Shock	100g; 6ms; half sine wave (3 times for each 3 directions X ,Y, Z),IEC 68-2-27 Test Ea/Severity 50A.				
	Drop	Test Condition: free drop on steel-made surface or rigid plane from a height of 100cm, IEC 68-2-32.				

2. Mechanical Structure (mm)

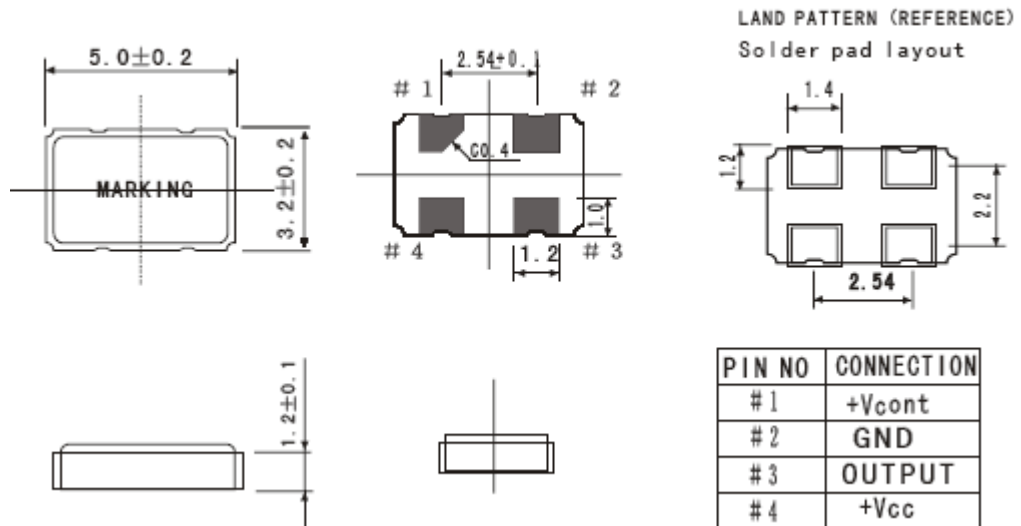

Note1: Referential Weight 0.1g



3. Test Circuit

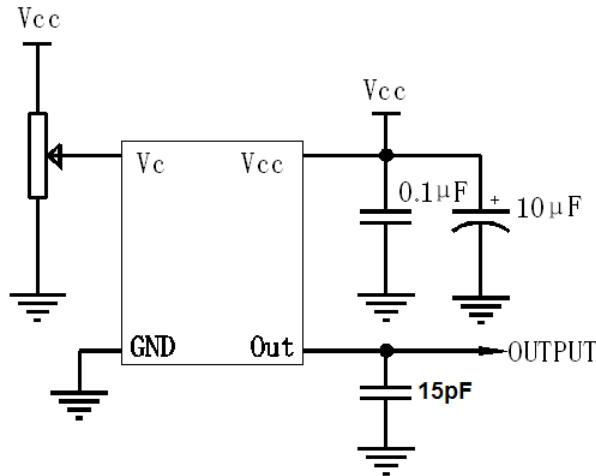

4. Reflow Soldering Curve (RoHS)

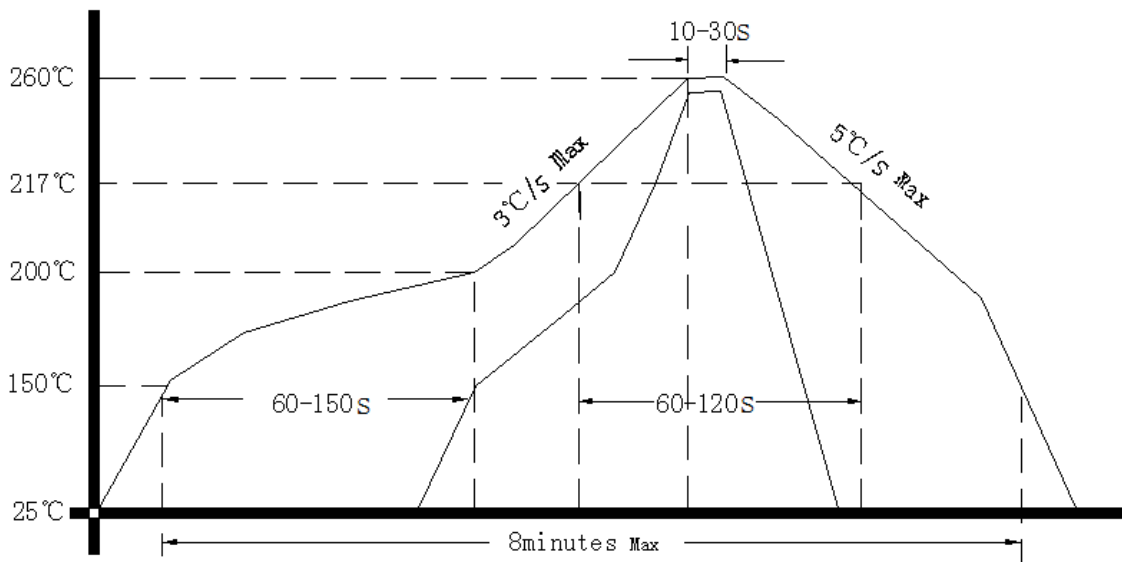

5. Package: Tape & Reel (mm)

