

Travelling Merchant: \_\_\_\_\_

# DATASHEET

Standard: CM65A-L126-10.00MHz

P/N: \_\_\_\_\_

Plot			The Label
Drew	Audited	Approved	Stamp, please! Thanks!
Date: 2014.07.04			

## Guangdong Dapu Telecom Technology Co.,Ltd

Bldg13-16,.N.Ind.Zone,SSL Industry Park, GuangDong City, Guangdong Province, China

TEL: 0086-0769-88010888 FAX: 0086-0769-81800098





## 1. Description

The CM65A-L126 is a high holdover performance, high integration, low noise clock module with patent compensated algorithm. After 2 days PRC level reference locking it can achieve better than  $1E-12$  frequency stability and holdover for 12 hours within  $\pm 3\mu s$  ( $\pm 20^{\circ}C$ ).

The CM65A-L126 provide many kinds of maintenance and alarm messages output to improve the reliability and maintainability of the network.

The CM65A-L126 is ideal for high performance frequency and time reference in wireline Telecommunications, wireless Telecommunications, substations, Test and Measurement Applications. It is the perfect replacement for rubidium clock.

## 2. Features

- Support all kinds of satellite receiver (GPS/GLONASS/BEIDOU/GALILEO) 1PPS output to be reference
- Ultra-Low phase noise output
  - 135 dBc/Hz (100Hz)
  - 148 dBc/Hz (1kHz)
- Ultra-High holdover ability close to Rubidium Clock
- Combine high stability OCXO and patent compensated algorithm
- High integration and small size (65mm×65mm×19mm)
- Various kinds of maintenance and alarm messages output
- 5V operation and low power consumption



### 3. Functional Block Diagram

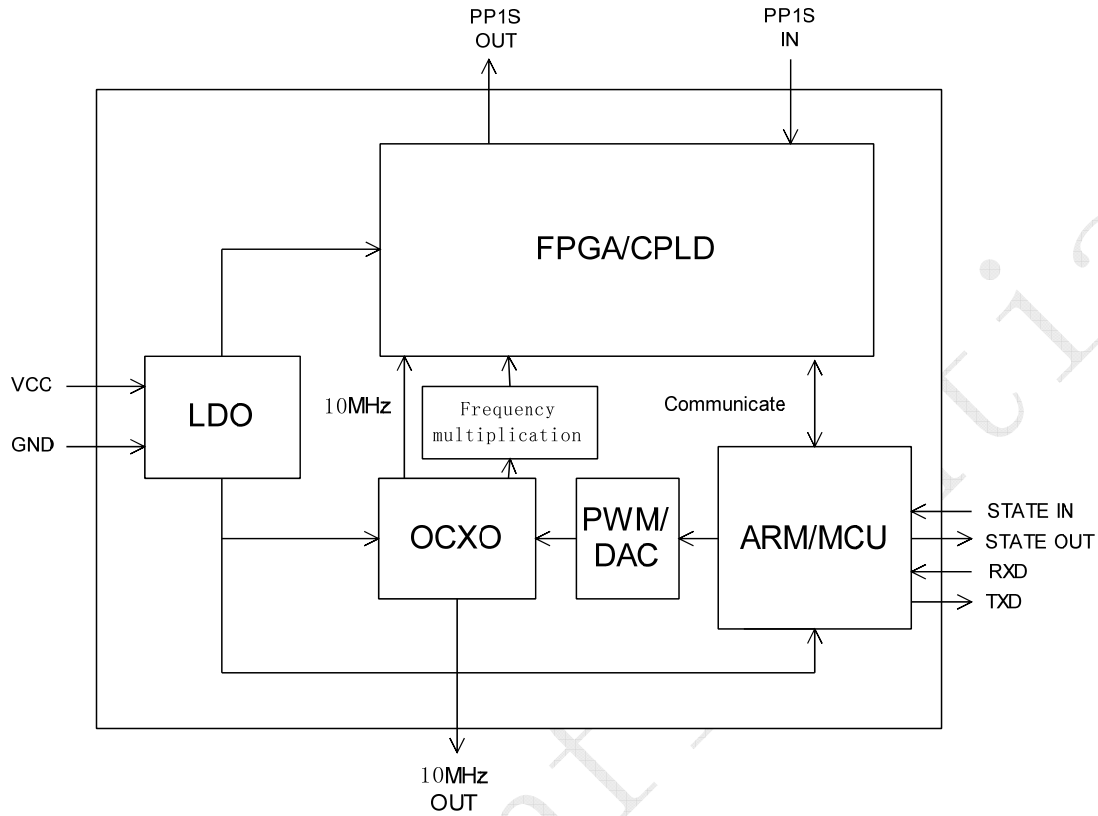

### 4. Applications

- Wireless base station
- Telecom Synchronization Network
- Power Grid Substation
- Test and Measurement
- Military/Aerospace

### 5. Electrical Parameters

	Parameters	Min.	Typ.	Max.	Unit.	Test Condition
1 PPS Reference Input	Waveform	HCMOS				50Ω
	High-Level Output Voltage (V <sub>IH</sub> )	2.7			V	
	Low-Level Output Voltage (V <sub>IL</sub> )			0.4	V	
	Pulse Width	10			μs	
	Stability			200	ns	
	Connector	Pin 10				



	Parameters	Min.	Typ.	Max.	Unit.	Test Condition	
State Input	Lock Enable	2.7			V	<5mA Load	
	Lock Disable			0.4	V	<5mA Load	
	Connector	Pin 8					
	Parameters	Min.	Typ.	Max.	Unit.	Test Condition	
10M Output	Nominal Frequency	10.00			MHz		
	Waveform	HCMOS					
	High-level Output Voltage (VOH )	2.7			V	<5mA Load	
	Low-level Output Voltage (VOL)			0.4	V	<5mA Load	
	Rise/Fall Time			8	ns	<5mA Load	
	Duty Cycle	45	50	55	%	<5mA Load	
	Frequency Tolerance vs. Operating Temperature Range	-0.05		+0.05	$\times 10^{-9}$	TA varied from -20°C to 75°C, measurement referenced to frequency observed with TA= 25°C, Vcc=5.0V, O <sub>Load</sub> =15pF. Temperature rise speed less than 1°C per minute.	
	Frequency Tolerance vs. Supply Voltage	-0.01		+0.01	$\times 10^{-9}$	measurement referenced to frequency observed T <sub>A</sub> =25°C, V <sub>cc</sub> varied from 4.75V to 5.25V, and O <sub>Load</sub> =15pF.	
	Retrace	-5		+5	$\times 10^{-9}$	@25°C, frequency variation measured after 48 hours power off and 3 hours power on, referred to stable frequency before power off.	
	Accuracy	-1		+1	$\times 10^{-12}$	24 hours average when locked to 1 PPS	
	Short-term Stability			5	$\times 10^{-12}$	Temperature stability, no EMI/EMC or other interference, test after power for 1 hour ref. to 25°C; 1s, using PN9000 equipment.	
	Aging Tolerance Per Day	-0.2		+0.2	$\times 10^{-9}$	V <sub>cc</sub> , T <sub>A</sub> constant measurement referenced to frequency observed with T <sub>A</sub> =25°C, V <sub>cc</sub> =5.0V, in FREE RUN condition and after 30 days of operation.	
	Aging Tolerance 1 Year	-0.01		+0.01	$\times 10^{-6}$		
	Phase Noise (All conditions)			-125	-120	dBc/Hz	10Hz
				-135	-130		100Hz
			-148	-143	1KHz		
			-152	-147	10KHz		



			-155	-150		100KHz	
			-155	-150		1MHz	
	Connector	Pin 2					
Holdover Time	Holdover times	Min.	Typ.	Max.	Unit.	Test Condition	
	5 Hours	-1.5		1.5	μs	ΔT = ±5°C turn on (1~3)days and lock more than 24hours.	
	6 Hours	-3		3		ΔT = ±20°C Temperature variable speed less than 1°C per minute	
	10 Hours	-1.5		1.5		ΔT = ±5°C holdover after turn on at least 3 days and lock 2days.	
	12 Hours	-3		3		ΔT = ±20°C Temperature variable speed less than 1°C per minute	
Supply Voltage	Parameters	Min.	Typ.	Max.	Unit.	Test Condition	
	Supply Voltage	4.75	5.0	5.25	V		
	Warm up time			15	mins		
	Current Consumption				2500	mA	During Warm-up
					1000	mA	During steady state operation @25°C
	AC Ripple			50	mVpk-pk	10Hz to 1MHz	
Connector	Pin 12						
1 PPS Output Waveform Characteristics	Parameters	Min.	Typ.	Max.	Unit.	Test Condition	
	Waveform	HCMOS					
	High-Level Output Voltage(V <sub>OH</sub> )	2.7			V	50Ω	
	Low-level Output voltage (V <sub>OL</sub> )			0.4	V		
	Pulse Width		100		ms		
	Phase Accuracy		-200		+200	ns	Initial lock status (the first 30mins after the fist time the CM65 got locked to the 1PPS )
			-80		+80	ns	lock status ( locked time ≥ 30mins, under the condition of 1PPS reference RMS ≤ 30ns)
Phase Accuracy (RMS)			25	ns	Steady lock status ( locked time ≥ 24hours, under the condition of 1PPS reference RMS ≤ 30ns)		



	Connector	Pin 3				
State Output	Parameters	Min.	Typ.	Max.	Unit.	Test Condition
	Lock	2.7			V	<5mA Load
	Free run/Holdover			0.4	V	<5mA Load
	Connector	Pin 5				
Serial Interfaces	Parameters	Min.	Typ.	Max.	Unit.	Test Condition
	Rx high-level Input Voltage (VH )	2.7			V	
	Rx low-level Input Voltage (VL)			0.4	V	
	Tx high-level Output Voltage (VH )	2.7			V	
	Tx low-level Output Voltage (VL)			0.4	V	
	Serial Protocol	9600-N-8-1				
	Connector	Pin6 and Pin7				
Environmental Conditions	Parameter	Conditions				
	Operating temperature	-30°C to +75°C				
	Storage Temperature	-55°C to +105°C				
	Storage humidity	30%~80%				
	ESD Level	Human Body Model,class2: 2000V to 4000V; ANSI/ESDA/JEDEC JS-001-2010.				
		Machine Model, class B: 200V to 400V; ANSI/ESDA/JEDEC JS-001-2010.				
	Moisture Sensitivity Level	Not humidity sensitive.				
	Vibration	Test Condition: 0.75mm ;acceleration:10g;10Hz~500Hz, one cycle per 30 min, test 2 hour. (3 times for each 3 directions X ,Y , Z), IEC 68-2-06 Test Fc.				
Shock	50g; 11ms; half sine wave (3 times for each 3 directions X ,Y , Z ),IEC 68-2-27 Test Ea/Severity 50A.					



## 6. Typical Application

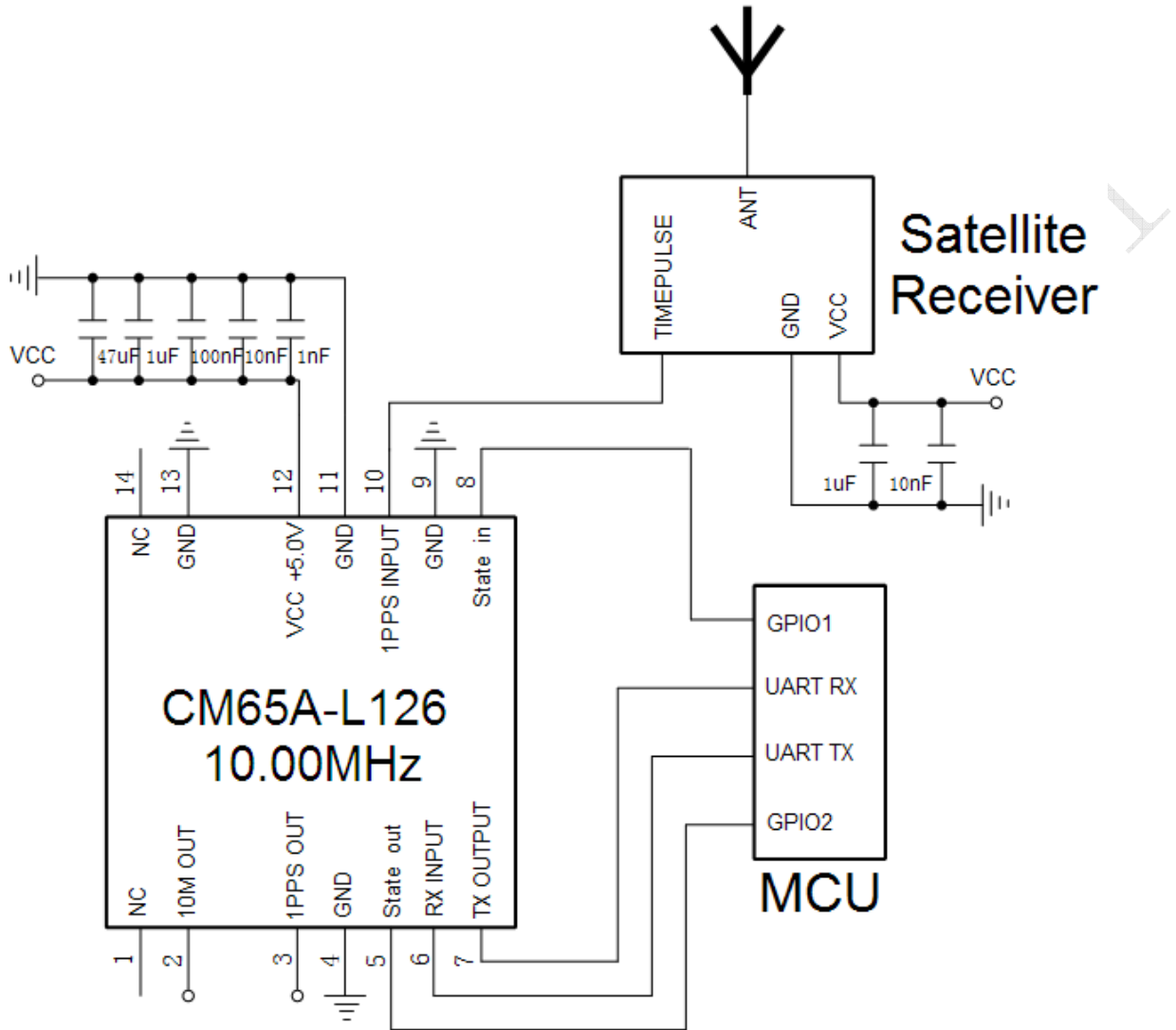





### 7. Mechanical Structure(mm)

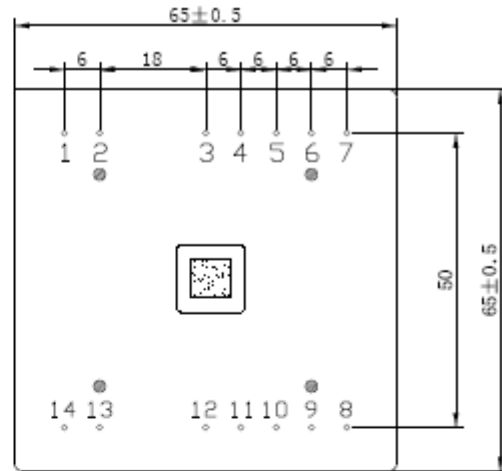

Bottom view

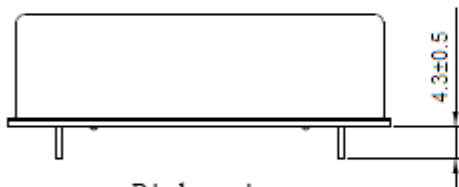

Right view

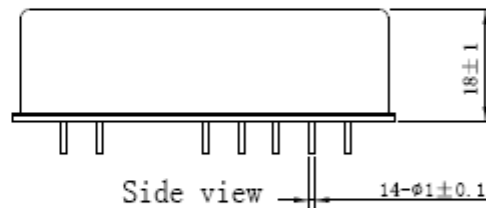

Side view

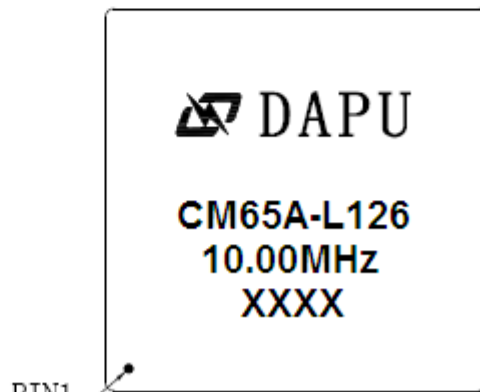

Top view

- Note1:** Tolerance ± 0.2mm without mark
- Note2:** The first two xx representative: week  
After two xx representative: year
- Note3:** Referential Weight 135±15g

**PIN DEFINITION**

PIN	Name	DESCRIPTION	
2	10M OUTPUT	10MHz OCXO frequency output.	
3	1PPS OUTPUT	The clock module 1PPS output.	
5	State OUTPUT	State output. Output high level when the CM is locked and stable, others low level.	
6	RX INPUT	Asynchronous serial data input.9600-N-8-1.	
7	TX OUTPUT	Asynchronous serial data output.9600-N-8-1.	
8	State INPUT	H: Lock Enable	The work state is set to normal operation when the state input is high level.
		L: Lock Disable	The module cannot be locked when the state input is low level.
10	1PPS INPUT	1PPS reference input.	
12	VCC	Power supply input, 4.75V to 5.25V.	
1、14	NC	Not connected.	
4、9、11、13	GND	GND	

**8. The Output Message Protocol**

In the Format column, c stand for char ,d stand for digit, s stand for sign.

Field No.	Name	Format	Description	Length (byte)
0	\$PDP	\$ccc	Message ID, DAPU Telecom Technology protocol header	4
1	No	dd	Message No.	2
2	TxRxFlag	d	The transmit and receive flag.(0: upper computer transmit; 1: upper computer receive)	1
3	CStatus	c	Current status.(F: warm-up; L: Lock; H: Hold over)	1
4	TrackStatus	d	Track status (Q: fast track;S: slow track)	1
5	cPHDiff	sdddd	Current phase difference, 1 unit stand for 6.25ns	5
6	cPWM1	dddd.dddd	Current PWM1 (Voltage-controlled value1)	10
7	cPWM2	dddd.dddd	Current PWM2 (Voltage-controlled value2), not used, output 32769.0000 as default.	10
8	SYNCNT	ddd	The synchronous times	3
9	HCNT	ddd	Power on hours count	3
10	HPAVG	dddd.dddd	The average of the PWM in the last half hour	10
11	VCH1	dddd.dddd	Voltage-controlled compensation value	10



			every half hour	
12	HPMOD	dddd.dddd	The Module PWM Value	
13	VCM10	dddd.dddd	Voltage-controlled compensation value every 10 minutes	10
14	POS	d-dd	The position of the product.(Layer-No), just for the inner test.	4
15	TEMP	sddd.dddd	The temperature monitored inside the module	9
16	AlarmFlag	sddd	The first 4 bytes are invalid, only the last 1 byte indicate Alarm flag(0: Normal; 1:OCXO heat up abnormal; 2:OCXO output abnormal; 3:The inside temperature sensor abnormal)	5
17	Website		www.dptel.com	13
18	Version	d.d	version	3
19	Date	dddd-dd-dd	Date	10
20		dd	55	2
21	END		<CR><LF>	2

The message output from Tx(PIN7), 9600 baud rate, data bits 8, stop bit 1, parity bit none, flow control bit none.

### 9. Coding Rules

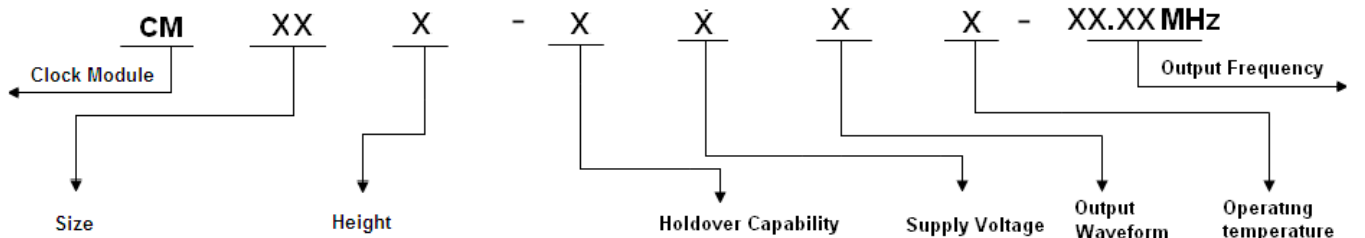

Size	Height	Holdover Capability	Supply Voltage	Output Waveform	Operating temperature
33 36×36 (mm)	A 19mm, single Freq, external GPS receiver	A ±1.5µs 0°C~60°C 24hours	1 5.0V	1 Sine Wave 2 HCMOS	1 0°C~80°C
55 50×50 (mm)	B 19mm, single Freq, internal GPS receiver	B ±3.0µs 0°C~60°C 24hours			2 -10°C~70°C
66 60×60 (mm)	C 19mm, single Freq, internal dual-mode receiver	C ±8.0µs 0°C~60°C 24hours			6 -30°C~75°C
65 65×65 (mm)	F 13mm, single Freq, external GPS receiver	D ±1.5µs ΔT=±5°C 24hours			8 -40°C~85°C
77 75×75 (mm)	G 13mm, single Freq, internal GPS receiver	E ±3.0µs ΔT=±5°C 24hours			9 -20°C~75°C
	H 13mm, dual-Freqs, internal GPS receiver	F ±8.0µs ΔT=±5°C 24hours			
	K 13mm, single Freq, internal dual-mode receiver	G ±1.5µs ΔT=±5°C 8hours			
	L 13mm, dual-Freqs, internal dual-mode receiver	H ±3.0µs ΔT=±5°C 8hours			
	P 13mm, for PTP, 1588 applications	I ±8.0µs ΔT=±5°C 8hours			
		K ±1.5µs ΔT=±2°C 24hours			
		L ±3.0µs ΔT=±20°C 12hours			
		M ±3.0µs ΔT=±2°C 24hours			
		N ±8.0µs ΔT=±2°C 24hours			
		O ±1.5µs ΔT=±2°C 8hours			
		P ±3.0µs ΔT=±2°C 8hours			
		Q ±8.0µs ΔT=±2°C 8hours			
		Z ±12µs ΔT=±5°C 12hours			



### 10.Reflow Soldering Curve (RoHS)

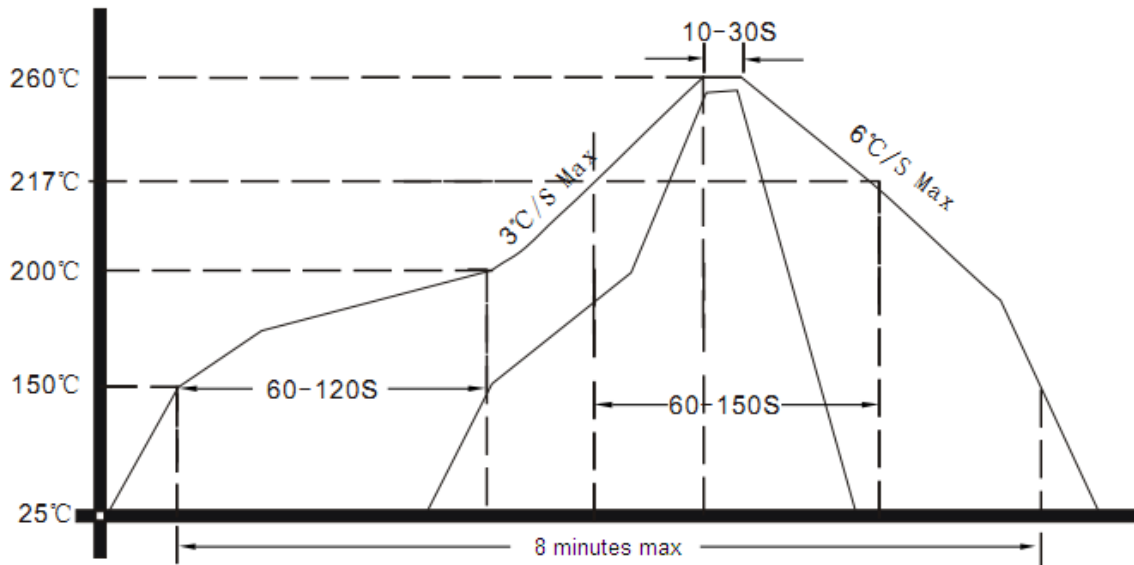

### 11.Package (mm)

