

Travelling Merchant: _____

DATASHEET

Standard: **T53-F319-15.36MHz**

P/N: _____

| Plot | | | The Label |
|------------------|---------|----------|------------------------|
| Drew | Audited | Approved | Stamp, please! Thanks! |
| | | | |
| Date: 2014.03.27 | | | |

Guangdong Dapu Telecom Technology Co.,Ltd

Bldg13-16,.N.Ind.Zone,SSL Industry Park, Dongguan City, Guangdong Province, China

TEL: 0086-0769-88010888 FAX: 0086-0769-81800098



1. Electrical Parameters

| MODEL: T53-F319-15.36MHz | | | | | | |
|--------------------------|---|------------|------|-------|------------------|---|
| Item | Description | Parameters | | | Unit | Test Condition |
| | | Min. | Typ. | Max. | | |
| Output | Frequency | 15.36 | | | MHz | |
| | Output Waveform | HCMOS | | | | |
| | Output Low Voltage | | | 0.4 | V | $V_{cc}=3.3V, O_{load}=15\text{ pF}$ |
| | Output High Voltage | 2.4 | | | V | $V_{cc}=3.3V, O_{load}=15\text{ pF}$ |
| | Duty Cycle | 45 | 50 | 55 | % | @50% |
| | Rise / Fall Time (10%~90%) | | | 8 | ns | @25°C |
| | Load | 15 | | | pF | |
| Frequency Stabilities | Frequency Tolerance vs. Operating Temperature Range | -0.5 | | +0.5 | $\times 10^{-6}$ | T_A varied from -40°C to 85°C, measurement referenced to frequency observed with $T_A = 25^\circ\text{C}$, $V_{cc} = 3.3V, O_{load} = 15\text{ pF}$, temperature variable speed less than 2°C per minute. |
| | Nominal Frequency Tolerance | -1 | | +1 | $\times 10^{-6}$ | Measurement referenced to frequency observed with $T_A=25^\circ\text{C}$, $V_{cc}=3.3V$, within 30 days after ex-works. |
| | Frequency Tolerance vs. Supply Voltage | -0.1 | | +0.1 | $\times 10^{-6}$ | measurement referenced to frequency observed $T_A=25^\circ\text{C}$, V_{cc} varied from 3.13V to 3.47V, and $O_{Load} = 15\text{ pF}$. |
| | Frequency Tolerance vs. Load | -0.2 | | +0.2 | $\times 10^{-6}$ | 5% load change measurement referenced to frequency observed with $T_A=25^\circ\text{C}$, $V_{cc}=3.3V$, and $O_{Load} = 15\text{ pF}$. |
| | Aging Tolerance Per Day | -0.02 | | +0.02 | $\times 10^{-6}$ | $T_A=25^\circ\text{C}$, $V_{cc}=3.3V$ and after 1h of operation. |
| | Aging Tolerance 1 Year | -1 | | +1 | $\times 10^{-6}$ | |
| Power Supply | Operating Current | | | 10 | mA | @25°C, $V_{cc}=3.3V, O_{Load}=15\text{ pF}$. |
| | Supply Voltage | 3.13 | 3.3 | 3.47 | V | |



| | | | | | | |
|--------------------------|----------------------------|--|------|------|--------|------|
| Phase Noise | Phase Noise @25°C | | -130 | -125 | dBc/Hz | 1KHz |
| Environmental Conditions | Operable Temperature | -40 | | +85 | °C | |
| | Storage Temperature | -55 | | +105 | °C | |
| | ESD Level | Human Body Model,class2: 2000V to 4000V; ANSI/ESDA/JEDEC JS-001-2010. Machine Model, class B: 200V to 400V; ANSI/ESDA/JEDEC JS-001-2010. | | | | |
| | Moisture Sensitivity Level | Level 2. | | | | |
| | Vibration | Test Condition: 0.75mm ;acceleration:10g;10Hz~2000Hz, one cycle per 30 min, test 2 hour. (3 times for each 3 directions X , Y , Z) .IEC 68-2-06 Test Fc. | | | | |
| | Shock | 100g; 6ms; half sine wave (3 times for each 3 directions X , Y , Z),IEC 68-2-27 Test Ea/Severity 50A. | | | | |

2. Mechanical Structure(mm)

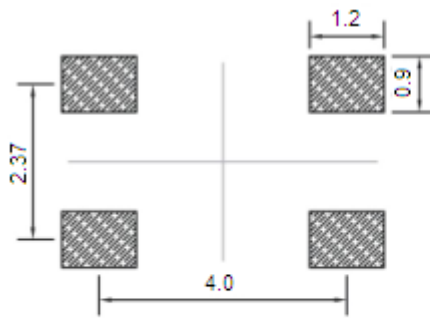

Solder pad layout

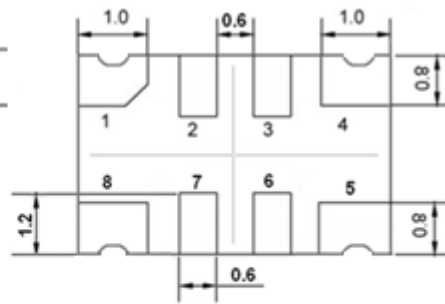

Bottom view



Side view

PIN FUNCTION

| PIN | FUNCTION |
|-----|----------|
| 1 | NC |
| 2,3 | NC |
| 4 | GND |
| 5 | OUTPUT |
| 6,7 | NC |
| 8 | VCC |

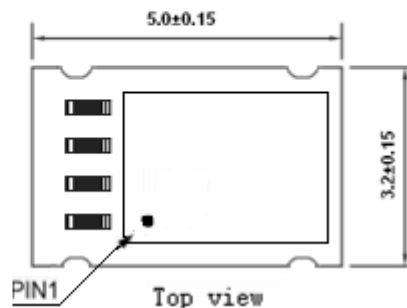

Top view

Note1: Tolerance ±0.1mm without mark

Note2: Referential Weight 0.05g

Note3: NC is not connect



3. Test Circuit

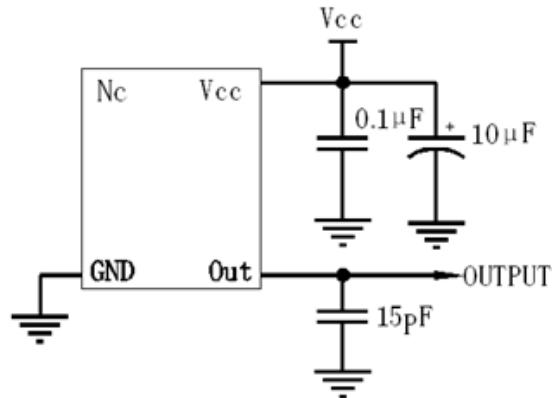

4. Reflow Soldering Curve (RoHS)

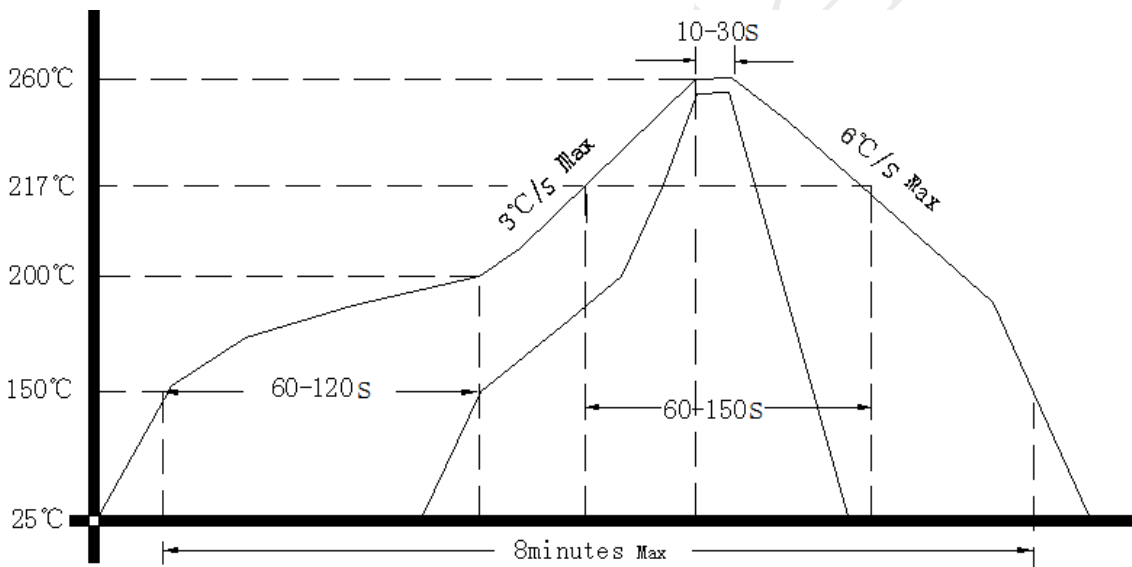

5. Package: Tape & Reel (mm)

