

Travelling Merchant: _____

DATASHEET

Standard: **T75B-H529-10.00MHz**

P/N: _____

Plot			The Label
Drew	Audited	Approved	Stamp, please! Thanks!
Date: 2013.12.12			

Guangdong Dapu Telecom Technology Co.,Ltd

Bldg13-16,.N.Ind.Zone,SSL Industry Park, Dongguan City, Guangdong Province, China

TEL: 0086-0769-88010888 FAX: 0086-0769-81800098



1. Electrical Parameters

MODEL: T75B-H529-10.00MHz						
Item	Description	Parameters			Unit	Test Condition
		Min.	Typ.	Max.		
Output	Frequency	10.00			MHz	
	Output Waveform	Clipped Sine Wave				
	V _{p-p}	0.8			V	
	Load	10KΩ//10pF				
Frequency Stabilities	Frequency Tolerance vs. Operating Temperature Range	-2		+2	× 10 ⁻⁶	T _A varied from -40°C to 85°C, measurement referenced to frequency observed with T _A =25°C, V _{cc} =5.0V, O _{load} =10KΩ//10pF, temperature variable speed less than 2°C per minute.
	Initial Frequency Tolerance	-1		+1	× 10 ⁻⁶	Measurement referenced to frequency observed with T _A =25°C, V _{cc} =5.0V within 30 days after ex-works.
	Nominal Frequency	-1		+1	× 10 ⁻⁶	@25°C, 2 times reflow soldering.
	Frequency Tolerance vs. Supply Voltage	-0.1		+0.1	× 10 ⁻⁶	measurement referenced to frequency observed T _A =25°C, V _{cc} varied from 4.75V to 5.25V, and O _{Load} =10KΩ//10pF.
	Frequency Tolerance vs. Load	-0.2		+0.2	× 10 ⁻⁶	10% load change measurement referenced to frequency observed with T _A =25°C, V _{cc} =5.0V, O _{Load} =10KΩ//10pF.
	Short-Term Stability: Allan Variance			1	× 10 ⁻⁹	Temperature stability, no EMI\EMC or other interference, test after power for 1 hour ref. to 25°C; 1s, using PN9000 equipment.
	Aging Tolerance Per Day	-0.02		+0.02	× 10 ⁻⁶	T _A =25°C, V _{cc} =5.0V, and after 1h of operation.
	Aging Tolerance 1 Year	-1		+1	× 10 ⁻⁶	
Power Supply	Current Consumption			2	mA	@25°C, V _{cc} =5.0V, O _{load} =10KΩ//10pF.
	Supply Voltage	4.75	5.0	5.25	V	
Phase Noise	Phase Noise		-65	-55	dBc/Hz	1Hz
			-95	-85		10Hz
			-120	-110		100Hz
			-140	-135		1KHz
			-150	-145		10KHz



Environmental Conditions	Operable Temperature	-40		+85	°C	
	Storage Temperature	-55		+125	°C	
	ESD Level	Human Body Model, class2: 2000V to 4000V; ANSI/ESDA/JEDEC JS-001-2010.				
		Machine Model, class B: 200V to 400V; ANSI/ESDA/JEDEC JS-001-2010.				
	Moisture Sensitivity Level	Level 2.				
	Vibration	Test Condition: 0.75mm ;acceleration:10g;10Hz~2000Hz, one cycle per 30 min, test 2 hours. (3 times for each 3 directions X , Y , Z) .IEC 68-2-06 Test Fc.				
Shock	100g; 6ms; half sine wave (3 times for each 3 directions X , Y , Z),IEC 68-2-27 Test Ea/Severity 50A.					

2. Mechanical Structure(mm)

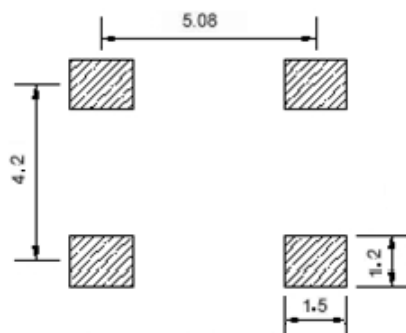

Solder pad layout



Right view

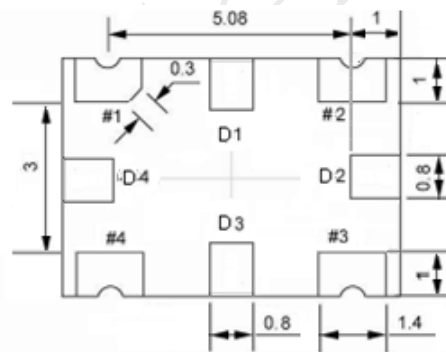

Bottom view



Side view

PIN FUNCTION

PIN	FUNCTION
D1,D2,D3,D4	NC
1	NC
2	GND
3	OUTPUT
4	VCC

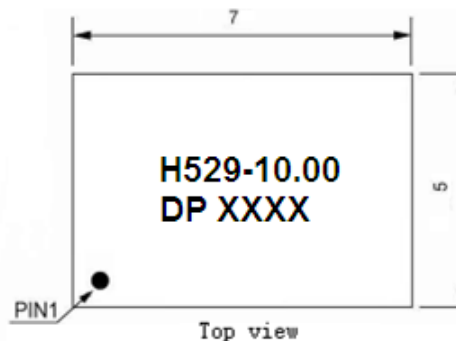

Top view

Note1: Tolerance $\pm 0.2\text{mm}$ without mark

Note2: The first two xx representative: week
After two xx representative: year

Note3: Referential Weight 0.2g

Note4: NC is not connect



3. Test circuit

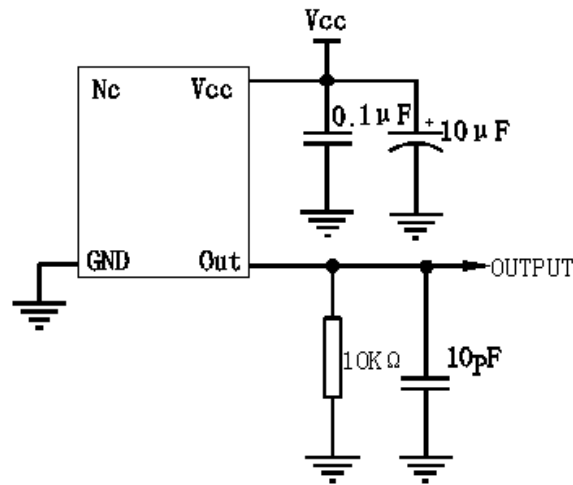

4. Reflow Soldering Curve (RoHS)

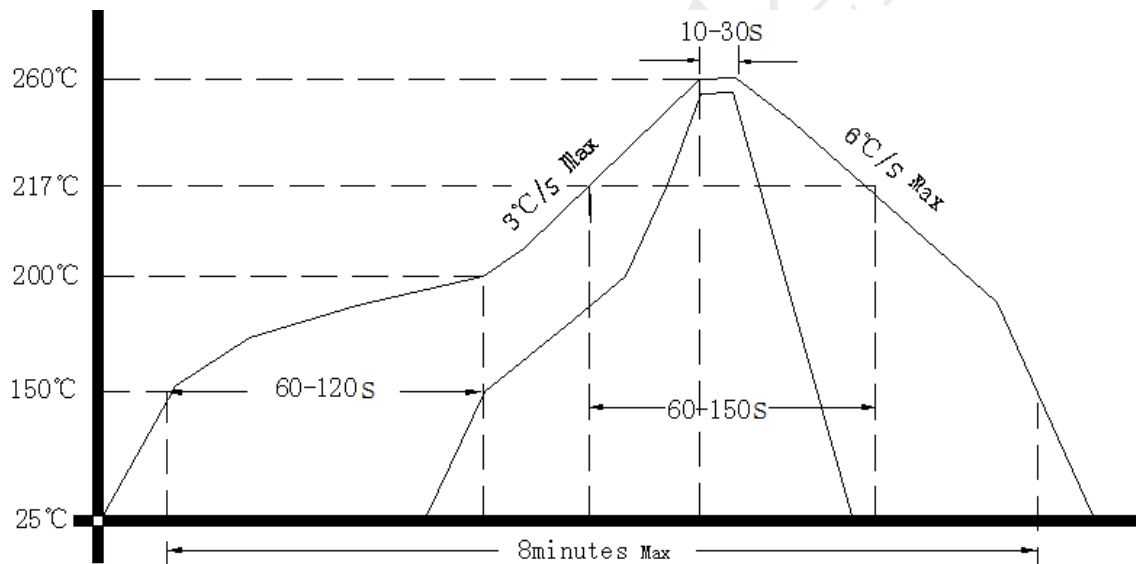

5. Package: Tape & Reel (mm)

