

Customer Code : _____

DATASHEET

DAPU P/N: _____ DPA3250M0000EH2ZNA0

DAPU			Customer Approval
Drew	Audited	Approved	Stamp, please! Thanks!
Jieshu ZHENG	Jianhua LIN	Gangtao FENG	
Date: 2025.02.18			

Guangdong Dapu Telecom Technology Co.,Ltd

Building 5, No.24, Industrial East Road, Songshanhu Park, Dongguan, Guangdong, P.R. China

TEL: 0086-0769-88010888 FAX: 0086-0769-81800098

**1. Electrical Parameters**

Item	Description	Parameters				Test Condition
		Min.	Min.	Min.	Unit	
1	Frequency	50.00			MHz	
2	Output Waveform	CMOS				
3	Load	15			pF	
4	Rise / Fall Time	-	-	10	ns	10%~90%V _{cc}
5	Start up Time	-	-	10	ms	
6	Duty Cycle	40	50	60	%	
7	Output Voltage High	0.9V _{cc}	-	-	V	
8	Output Voltage Low	-	-	0.1V _{cc}	V	
9	Initial Frequency Tolerance	-20	-	+20	×10 ⁻⁶	@25°C±2°C
10	Frequency Tolerance vs. Operating Temperature Range	-30	-	+30	×10 ⁻⁶	T _A varied from -40°C to 125°C, measurement referenced to frequency observed with f _{ref} =(f _{max} +f _{min})/2, V _{cc} =3.3V,
11	Supply Voltage (V _{cc})	1.71	3.3	3.63	V	
12	Current	-	-	30	mA	
13	Aging Tolerance	-3	-	+3	×10 ⁻⁶ /year	@25°C±2°C
14	Operable Temperature	-40	~	+125	°C	
15	Storage Temperature	-55	~	+125	°C	



2. Mechanical Structure (mm)

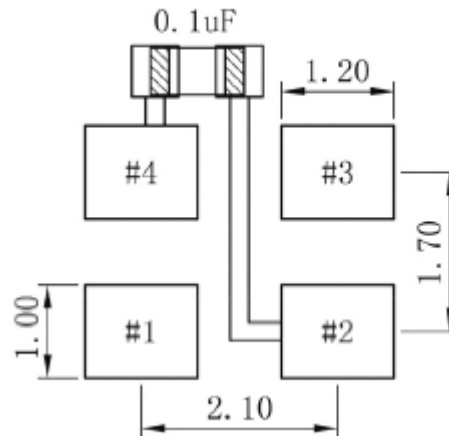
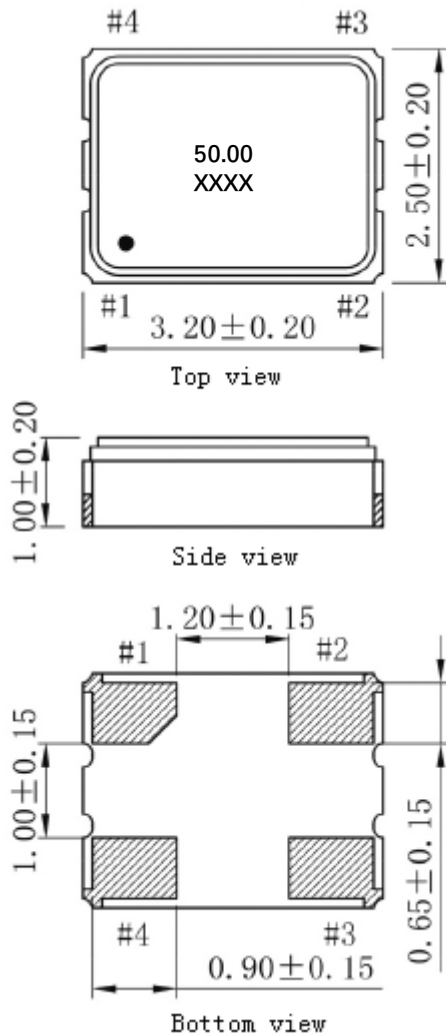

Note: The $0.1\mu\text{F}$ capacitor should be placed as close as possible to the 4-pin of the crystal oscillator

Solder Pad layout

PIN FUNCTION

PIN	NOTATION	FUNCTION
1	NC	Not Connect
2	GND	GND
3	OUTPUT	RF Output
4	VCC	Supply Voltage

Note1: The first two xx representative: year
The last two xx representative: week



3. Test Circuit

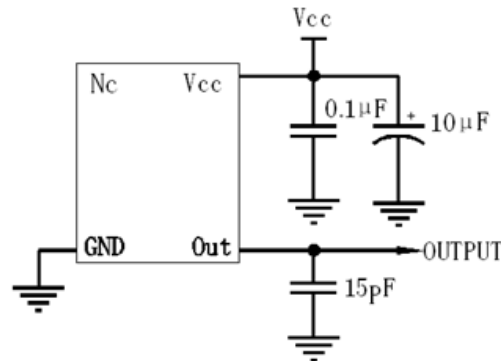

4. Reflow Soldering Curve (RoHS)

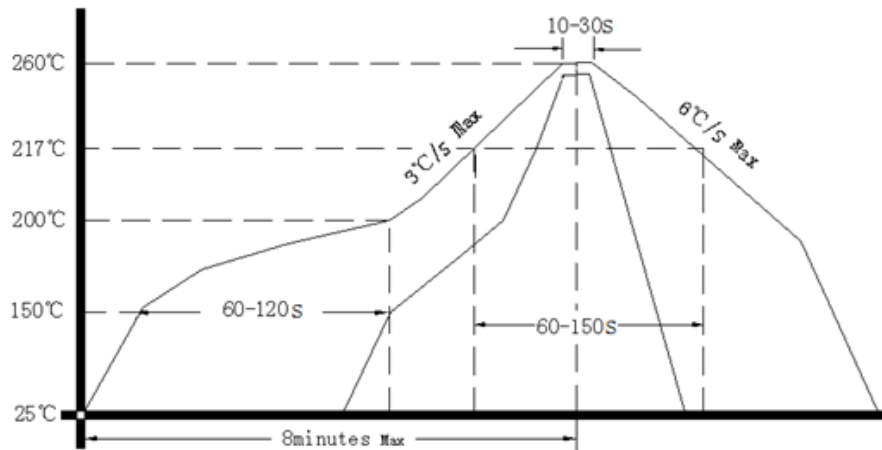

5. Package: Tape & Reel (mm)

