

Travelling Merchant: A008

DATASHEET

Standard: T75A-0803-38.88MHz

P/N: _____

Plot			The Label
Drew	Audited	Approved	Stamp, please! Thanks!
Date: 2024.01.29			

Guangdong Dapu Telecom Technology Co.,Ltd

Building 5, No.24, Industrial East Road, Songshanhu Park, Dongguan, Guangdong, P.R. China

TEL: 0086-0769-88010888 FAX: 0086-0769-81800098



Table of amendment

Version	Revision contents	Prepared by	Revised date
1.0	The first issued	Amway	2021.07.08
1.1	The “Initial Frequency Tolerance” “Aging Tolerance 1 Year” “Phase Noise” “RMS Jitter” changed	Amway	2021.07.23
1.2	The “Mechanical Structure” changed	Amway	2024.01.29



1. Electrical Parameters

MODEL: T75A-0803-38.88MHz						
Item	Description	Parameters			Unit	Test Condition
		Min.	Typ.	Max.		
Output	Frequency	38.88			MHz	
	Output Waveform	HCMOS				
	Output Low Voltage			0.33	V	V _{cc} =3.3V, O _{load} =15 pF
	Output High Voltage	2.97			V	V _{cc} =3.3V, O _{load} =15 pF
	Duty Cycle	45		55	%	@50%
	Rise / Fall Time (10%~90%)			10	ns	@25°C
	Load	15			pF	
Frequency Stabilities	Frequency Tolerance vs. Operating Temperature Range	-0.5		+0.5	× 10 ⁻⁶	T _A varied from -40°C to 105°C, measurement referenced to frequency observed with f _{ref} =(f _{max} +f _{min})/2, V _{cc} =3.3V, O _{load} =15pF, temperature variable speed less than 2°C per minute.
	Initial Frequency Tolerance		± 1.5		× 10 ⁻⁶	@ 10ms, T _A varied from -40°C to 105°C, V _{cc} varied from 2.97V to 3.63V, and 10% load.
	Frequency Tolerance vs. Supply Voltage	-0.1		+0.1	× 10 ⁻⁶	measurement referenced to frequency observed T _A =25°C, V _{cc} varied from 2.97V to 3.63V, and O _{Load} =15pF.
	Frequency Tolerance vs. Load	-0.1		+0.1	× 10 ⁻⁶	10% load change measurement referenced to frequency observed with T _A =25°C, V _{cc} =3.3V, O _{Load} =15pF.
	Holdover Stability Constant Temperature	-0.05		+0.05	× 10 ⁻⁶	24 hours, ≤ ± 2°C.
	Short Term Stability		0.1		× 10 ⁻⁹	Temperature stability, no EMI\EMC or other interference, test after power for 48hour ref. to 25°C; 1s.
	Slope Over Temperature		± 50	± 100	× 10 ⁻⁹ /°C	Δ F/ Δ T, 2°C/MIN.
	Reflow Shift	-1		+1	× 10 ⁻⁶	After 2X reflow, 24 hour, recovery at 25°C
	Acceleration Sensitivity		± 2		× 10 ⁻⁹ /g	Gamma vector, 3-axes, 30-1500Hz, typically less than.
	Aging Tolerance 1 Year		± 0.5	± 1	× 10 ⁻⁶	T _A =25°C, V _{cc} =3.3V, and after 30 days of operation.
	Aging Tolerance 20 Years	-3		+3	× 10 ⁻⁶	



	Run Accuracy	-4.6		+4.6	$\times 10^{-6}$	Tolerance at 25°C, frequency vs. change in temperature, change in supply voltage ($\pm 10\%$), load change ($\pm 10\%$), reflow soldering process and 20 years aging.
		-7		+7	$\times 10^{-6}$	Including calibration, temperature, load & supply, voltage changes and 10 years, aging at +85°C.
Power Supply	Current Consumption			10	mA	@25°C, $V_{cc}=3.3V$, $O_{Load}=15pF$.
	Supply Voltage	3.13	3.3	3.47	V	
Phase Noise	Phase Noise		-60	-55	dBc/Hz	1Hz
			-90	-84		10Hz
			-120	-114		100Hz
			-140	-134		1KHz
			-145	-142		10KHz
			-150	-145		40KHz
			-153	-150		100KHz
			-156	-153		1MHz
RMS Jitter	RMS Jitter		0.416	0.827	ps	10Hz-100kHz
Environmental Conditions	Operable Temperature	-40		+105	°C	
	Operable Environmental Condition	10%~90%RH				
	Storage Condition	Temperature: -50°C~+95°C, Humidity:5%~95%RH, Pressure:76kPa~106 kPa.				
	ESD Level	Human Body Model, class2: 2000V to 4000V; ANSI/ESDA/JEDEC JS-001-2010.				
		Machine Model, class B: 200V to 400V; JEDEC JESD22-A115C.				
	Moisture Sensitivity Level	Level 3.				
	Vibration	Test Condition: 0.75mm ;acceleration:10g;10Hz~2000Hz, one cycle per 30 min, test 2 hour. (3 times for each 3 directions X , Y , Z) .IEC 68-2-06 Test Fc.				
Shock	100g; 6ms; half sine wave (3 times for each 3 directions X , Y , Z),IEC 68-2-27 Test Ea/Severity 50A.					



2. Mechanical Structure(mm)

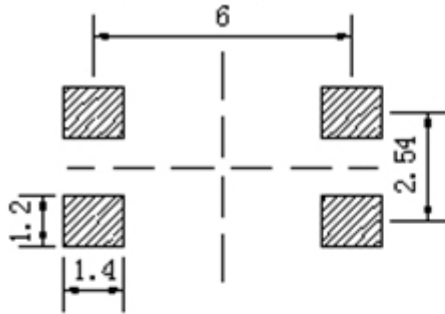

Solder pad layout

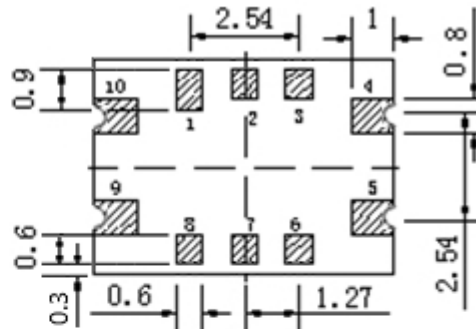

Bottom view



Right view



Front view

PIN FUNCTION

PIN	NOTATION	FUNCTION
1, 2, 3, 6, 7, 8	NC	Not Connect
4	GND	GND
5	OUTPUT	RF Output
9	VCC	Supply Voltage
10	NC	Not Connect

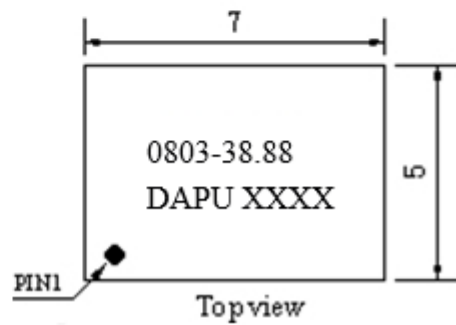

Topview

Note1: Tolerance ± 0.3 mm without mark

Note2: The first two xx representative: year

After two xx representative: week

Note3: Referential Weight 0.2g

Note4: NC is not connect



3. Test circuit

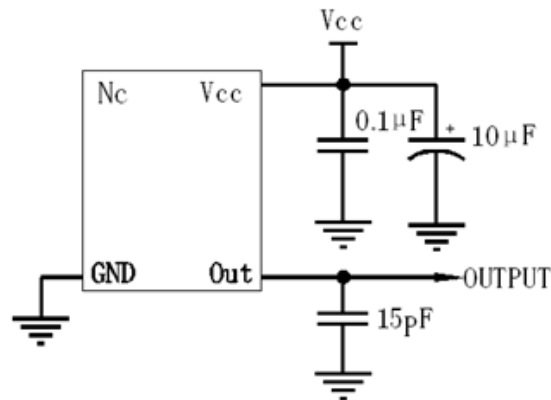

4. Reflow Soldering Curve (RoHS)

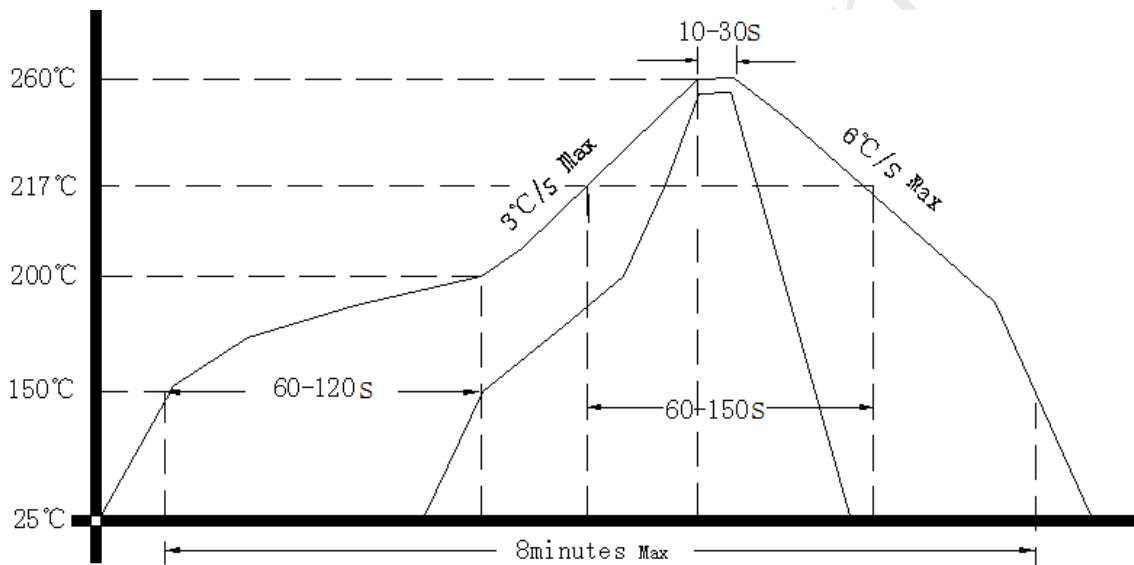

5. Package: Tape & Reel (mm)

