

**Customer Code:** \_\_\_\_\_

# DATASHEET

**DAPU P/N:** DPA2124M0000EFA0NB0

DAPU			Customer Approval
Drew	Audited	Approved	Stamp, please! Thanks!
Jieshu ZHENG	Jianhua LIN	Gangtao FENG	
Date:	2024/7/5		

## Guangdong Dapu Telecom Technology Co.,Ltd

Bldg 5, SSL Modern Enterprise Accelerator Zone, Dongguan City, Guangdong Province, PRC China  
TEL: 0086-0769-88010888 FAX: 0086-0769-81800098



## 1、Electrical Parameter

MODEL :		DPA2124M0000EFA0NB0					
For Automotive							
No.	Parameters	SYM.	Electrical Spec.				Notes
			Min.	Typ.	Max.	Units	
1	Nominal Frequency	FL	24.000			MHz	
2	Oscillation Mode	-	Fundamental				
3	Frequency Tolerance	-	-10		10	ppm	At 25°C
4	Frequency Stability	-	-30		30	ppm	-40°C~105°C (Reference 25°C)
5	Operating Temperature	Topr	-40		105	°C	
6	Storage Temperature	Tstg	-55		125	°C	
7	Supply Voltage	VDD	1.62		3.63	V	
8	Input Current	Icc			10	mA	
9	Output waveform	-	CMOS				
10	Output Load	CL	15			pF	
11	Output Voltage High	VOH	0.9			VDD	
12	Output Voltage Low	VOL			0.1	VDD	
13	Rise Time	Tr			5	ns	10% -90% VDD Level
14	Fall Time	Tf			5	ns	90% -10% VDD Level
15	Aging	-	-3		3	ppm	First Year at 25°C
16	Tri-State Output Enable	-	0.7			VDD	Pin 1, OE or ST
17	Tri-State Output Disable	-			0.3	VDD	Pin 1, OE or ST
18	Duty Cycle	-	45~55			%	
19	Start-Up Time	Tstart			2	ms	Measured from the time VDD reaches its rated minimum value.
20	Standard	-	AEC-Q100			-	

## 2、 Mechanical Structure

### 2.1 Dimensions

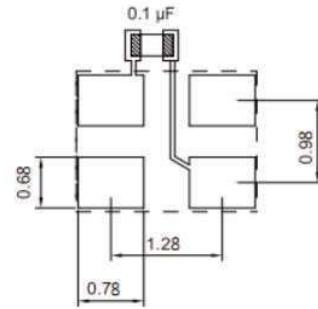
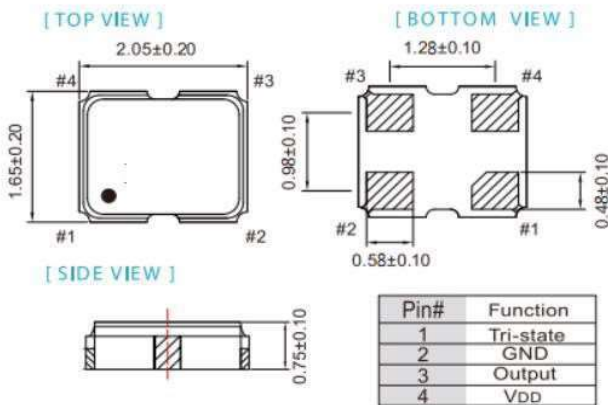

To ensure optimal oscillator performance, place a by-pass capacitor of 0.1µ as close to the part as possible between Vdd and GND pads.

### 2.2 Marking

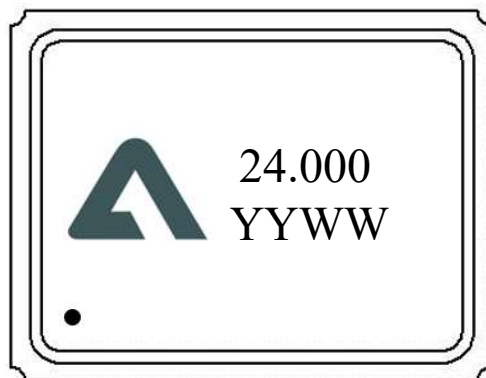

-----DAPU LOGO

**24.000** -----Frequency

YY:Year                  WW: Week



-----Pin 1

### 3、 Test Circuit

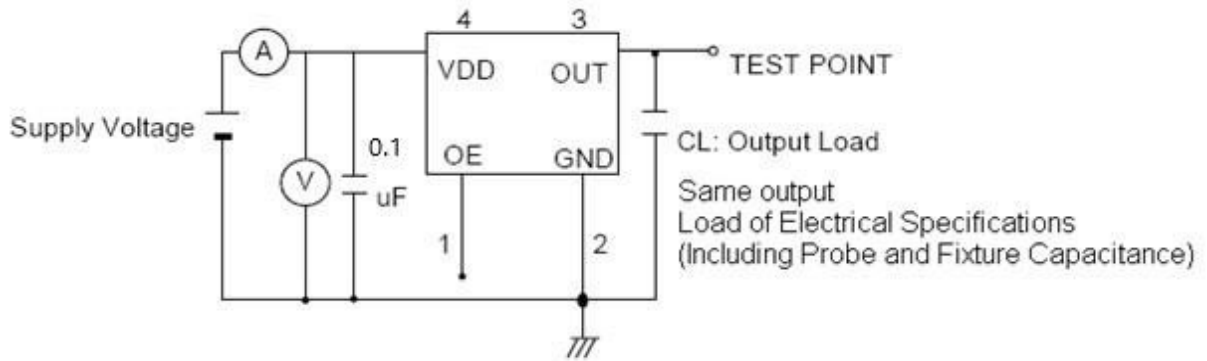

Control input (output enable/disable)

Tri-State Pin	Output Pin
Logic 1 or open on pad 1	Oscillator output
Logic 0 on pad 1	Disable output to high impedance

### 4、 Reflow Soldering Curve (RoHS)

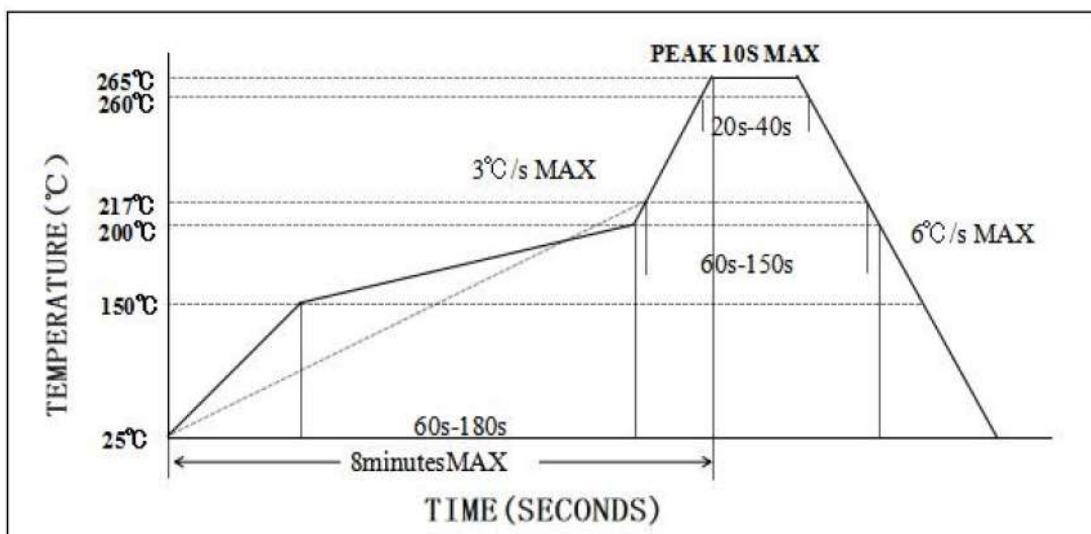

### 5、 Package: Tape & Reel (mm)

