

Customer Code: _____

DATASHEET

DAPU P/N: T3225C-1201-19.44MHz-D0

DAPU			Customer Approval
Drew	Audited	Approved	
Jieshu ZHENG	Jianhua LIN	Gangtao FENG	
Date:	2024/7/4		
			Stamp, please! Thanks!

Guangdong Dapu Telecom Technology Co.,Ltd

Bldg 5, SSL Modern Enterprise Accelerator Zone, Dongguan City, Guangdong Province, PRC China
TEL: 0086-0769-88010888 FAX: 0086-0769-81800098

1、Electrical Parameter

MODEL:		T3225C-1201-19.44MHz-D0				
No.	Description	Parameters			Units	Test Condition
		Min.	Typ.	Max.		
Output	Frequency	19.440			MHz	
	Output Waveform	HCMOS				
	High Level	2.4			V	V _{CC} =3.3±5%, O _{Load} =15pF.
	Low Level			0.4	V	
	Symmetry	45	50	55	%	
	Rise / Fall Time (10%~90%)			5	ns	at 25°C
	Load	15pF			-	
Frequency Stabilities	Frequency Tolerance	-1		1	×10 ⁻⁶	@25±2°C, 2H, after 2 times reflow soldering, base on nominal frequency.
	vs. Temperature	-1		1	×10 ⁻⁶	T _A varied from -40°C to 85°C, measurement referenced to frequency observed with f _{ref} =(f _{max} +f _{min})/2, V _{CC} =3.3V, O _{load} =15pF , temperature variable speed less than 2°C per minute.
	vs. Supply Voltage	-0.2		0.2	×10 ⁻⁶	measurement referenced to frequency observed T _A =25°C, V _{CC} =3.3±5%, and O _{Load} =15pF.
	vs. Load	-0.2		0.2	×10 ⁻⁶	10% load change measurement referenced to frequency observed with T _A =25°C, V _{CC} =3.3V, and O _{Load} =15pF.
	Aging Tolerance 1 Year	-1		1	×10 ⁻⁶	T _A =25°C, V _{CC} =3.3V, and after 1h of operation.
Power Supply	Current consumption			3	mA	@25°C, V _{CC} =3.3V, O _{Load} =15pF.
	Start up Time			2	ms	More than 90% of final output voltage
	Supply Voltage	2.97	3.30	3.63	V	
SSB Phase Noise	Phase Noise@25±2°C			-	dBc/Hz	1Hz
			-88	-83		10Hz
			-112	-107		100Hz
			-135	-130		1KHz
			-145	-140		10KHz
			-145	-140		100KHz
			-148	-143		1MHz

Environmental Conditions	Operable Temperature	-40		85	°C	
	Storage Temperature	-55		105	°C	
	ESD Level	Human Body Model, class 2: 2000V to 4000V; ANSI/ESDA/JEDEC JS-001-2010.				
		Machine Model, class B: 200V to 400V; JEDEC JESD22-A115C.				
	Moisture Sensitivity Level	Level 1.				
	Vibration	Test Condition: 0.75mm ;acceleration:10g;10Hz~2000Hz, one cycle per 30 min, test 2 hour. (3 times for each 3 directions X ,Y, Z) .IEC 68-2-06 Test Fc.				
Shock	100g; 6ms; half sine wave (3 times for each 3 direction s X ,Y, Z), IEC 68-2-27 Test Ea/Severity 50A.					
Full Package Storage	Relative humidity (%)	20%~70%				
	Temperature (°C)	-10~35°C				

2 Test Circuit

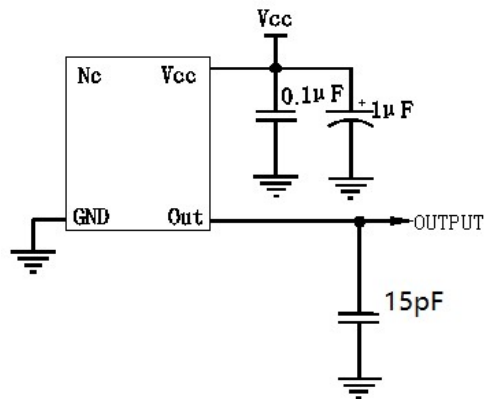

3. Reflow Soldering Curve (RoHS)

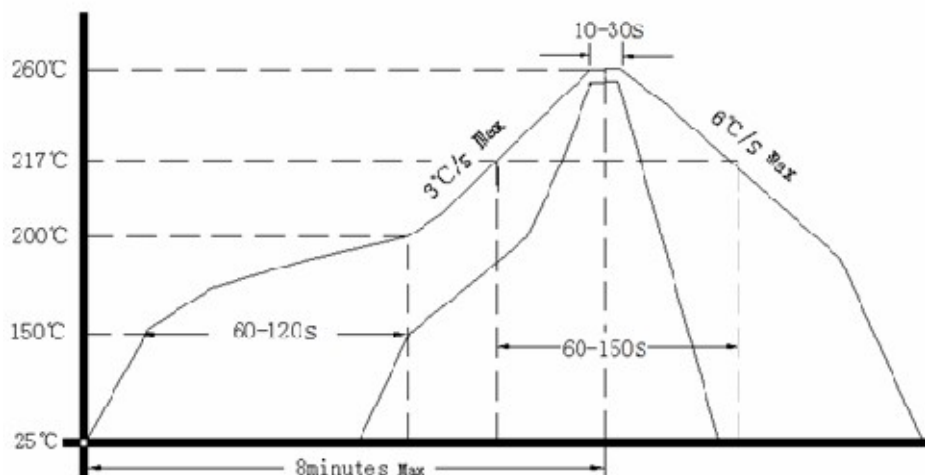

4、 Mechanical Structure(mm)

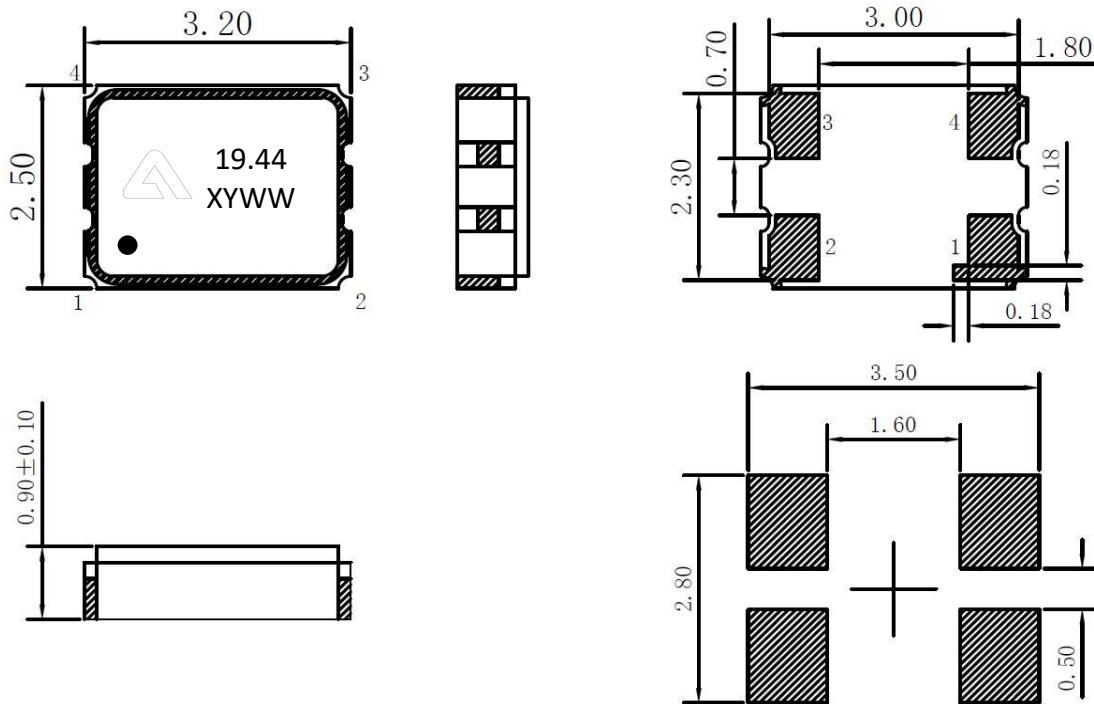

PIN NAME	CONNECTION
PIN1	NC
PIN2	GND
PIN3	OUTPUT
PIN4	VCC

5、 Marking Information

19.44:	Frequency 19.44MHz
:	DAPU Logo
X:	Internal code.
Y:	Year
WW:	Week
:	Pin1 Index

6、 Packing Information

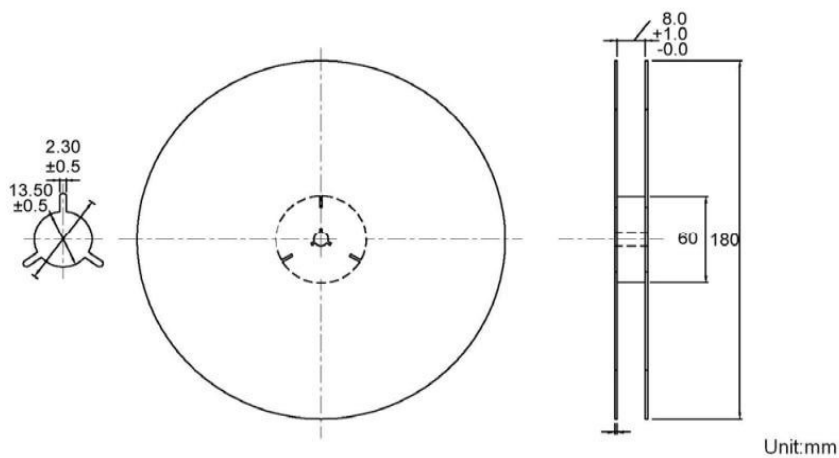
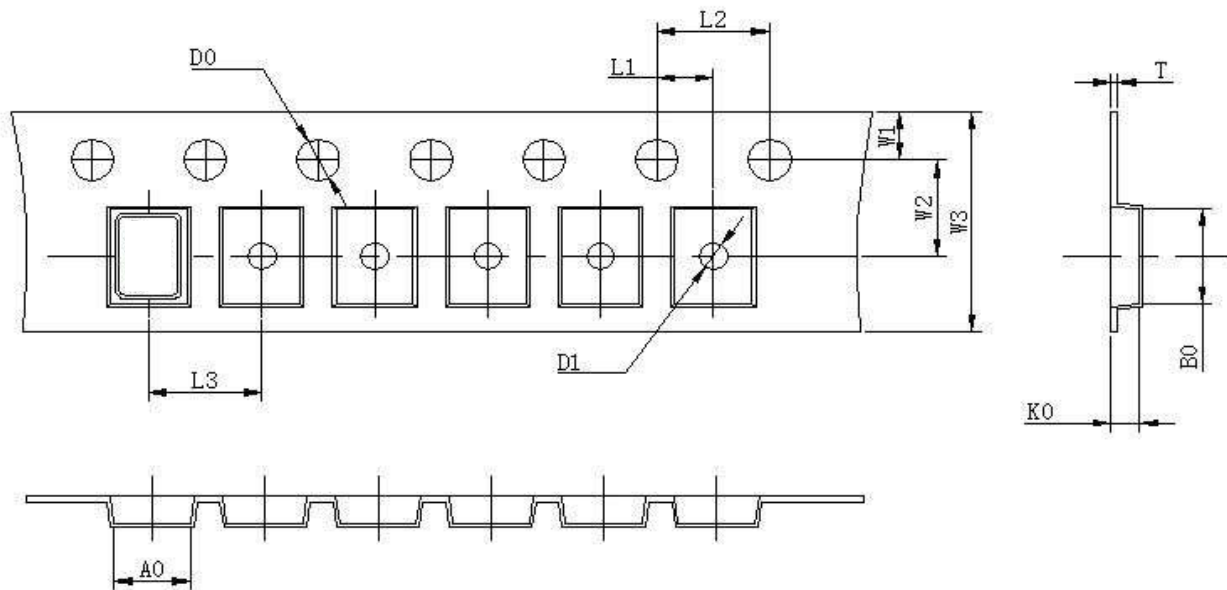

L1	2.00 ±0.1
L2	4.00 ±0.1
L3	4.00 ±0.1
D0	1.55 ±0.05
D1	1.20 ±0.5
W1	1.75 ±0.1
W2	3.50 ±0.1
W3	8.00 ±0.2
A0	2.7 ±0.1
B0	3.4 ±0.1
K0	1.40 ±0.1
T	0.25 ±0.05