

Travelling Merchant: _____

DATASHEET

Standard: **O11F-0802-10.00MHz**

P/N: _____

Plot			The Label
Drew	Audited	Approved	Stamp, please! Thanks!
Date: 2024.04.11			

Guangdong Dapu Telecom Technology Co.,Ltd

Building 5, No.24, Industrial East Road, Songshanhu Park, Dongguan, Guangdong, P.R. China

TEL: 0086-0769-88010888 FAX: 0086-0769-81800098



1. Electrical Parameters

MODEL: O11F-0802-10.00MHZ						
Item	Description	Parameters			Unit	Test Condition
		Min.	Typ.	Max.		
Output	Frequency	10.00			MHz	
	Output Waveform	HCMOS				
	Output Low Voltage			0.4	V	$V_{cc}=3.3V, O_{load}=15pF$
	Output High Voltage	2.4			V	$V_{cc}=3.3V, O_{load}=15pF$
	Duty Cycle	45		55	%	@50%
	Rise / Fall Time (10%~90%)			10	ns	
	Load		15		pF	
Frequency Stabilities	Frequency Tolerance vs. Operating Temperature Range	-5		+5	$\times 10^{-9}$	T_A varied from $-40^{\circ}C$ to $85^{\circ}C$, measurement referenced to frequency observed with $f_{ref}=(f_{max}+f_{min})/2, V_{cc}=3.3V, O_{load}=15pF$, temperature rise speed less than $2^{\circ}C$ per minute.
	Initial Frequency Tolerance	-0.2		+0.2	$\times 10^{-6}$	Measurement referenced to frequency observed with $T_A=25^{\circ}C, V_{cc}=3.3V, V_c=1.65V$, at the shipment.
	Frequency Tolerance vs. Supply Voltage	-5		+5	$\times 10^{-9}$	measurement referenced to frequency observed $T_A=25^{\circ}C, V_{cc}$ varied from $3.267V$ to $3.333V$, and $O_{Load}=15pF$.
	Frequency Tolerance vs. Load	-5		+5	$\times 10^{-9}$	10% load change measurement referenced to frequency observed with $T_A=25^{\circ}C, V_{cc}=3.3V, V_c=1.65V$ and $O_{Load}=15pF$.
	Reflow Shift	-0.2		+0.2	$\times 10^{-6}$	$T_A=25^{\circ}C$, After 1 hour
	Frequency Slope	-0.3		+0.3	$\times 10^{-9}/^{\circ}C$	Temperature ramp $\leq 1^{\circ}C/min$, in still air
	Aging Tolerance Per Day	-1		+1	$\times 10^{-9}$	V_{cc}, T_A constant measurement referenced to frequency observed with $T_A=25^{\circ}C, V_{cc}=3.3V, V_c=1.65V$ and after 30 days of operation.
	Aging Tolerance 1 Year	-0.3		+0.3	$\times 10^{-6}$	
	Aging Tolerance 20 Years	-2.5		+2.5	$\times 10^{-6}$	
	All Causes Stability	-4.6		+4.6	$\times 10^{-6}$	Including calibration, temperature, supply voltage & load changes and 20 years life, reference to F_n .



Power Supply	Supply Voltage	3.135	3.3	3.465	V	
	Steady Consumption			400	mA	@25°C
	Warm up current			800	mA	
	Warm-Up Time			60	s	@25°C within $\pm 0.2 \times 10^{-6}$ of final frequency with reference after 1 hours on.
Voltage Control Characteristics	Frequency Tuning Range	-4		-2	$\times 10^{-6}$	$V_c=0V$. measurement referenced to $V_c=1.65V$
		-0.2		+0.2	$\times 10^{-6}$	$V_c=1.65V$. measurement referenced to exactly 10.00MHz
		+2		+4	$\times 10^{-6}$	$V_c=3.3V$. measurement referenced to $V_c=1.65V$
	Linearity			10	%	
	Slope		1.4		$\times 10^{-6}/V$	
	Input Impedance	80			K Ω	
	Modulation Bandwidth		3.5		Hz	-3db cut-off
Phase Noise	Phase Noise @25°C		-82	-72	dBc/Hz	1Hz
			-113	-103		10Hz
			-141	-131		100Hz
			-157	-152		1kHz
			-159	-154		10kHz
			-159	-154		100kHz
			-159	-154		1MHz
RMS Jitter	RMS Jitter		0.5		ps	12kHz to 5MHz
Environmental Conditions	Operable Temperature	-40		+85	°C	
	Storage Temperature	-55		+125	°C	
	ESD Level	Human Body Model, class2: 2000V to 4000V; ANSI/ESDA/JEDEC JS-001-2010.				
		Machine Model, class B: 200V to 400V; JEDEC JESD22-A115C.				
	Moisture Sensitivity Level	Level 2.				
	Vibration	Test Condition: 0.75mm ;acceleration:10g;10Hz~500Hz, one cycle per 30 min, test 2 hour. (3 times for each 3 directions X ,Y , Z), IEC 68-2-06 Test Fc.				
Shock	50g; 11ms; half sine wave (3 times for each 3 directions X, Y, Z), IEC 68-2-27 Test Ea/Severity 50A.					
Full Package Storage	Relative humidity (%)	20% ~ 70%				
	Temperature (°C)	-10~35°C				



2. Mechanical Structure (mm)

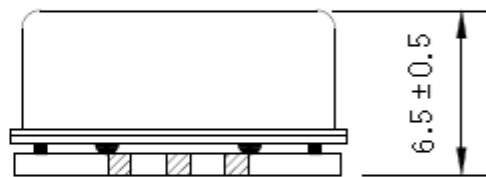
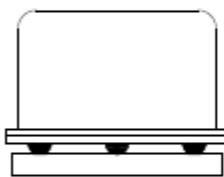
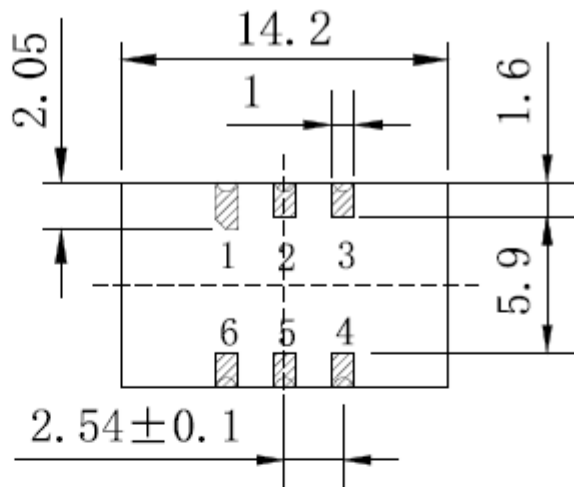

PIN FUNCTION

PIN	NOTATION	FUNCTION
1	NC	Not Connect
2,5	NC	Not Connect
3	GND	GND
4	OUTPUT	RF Output
6	VCC	Supply Voltage

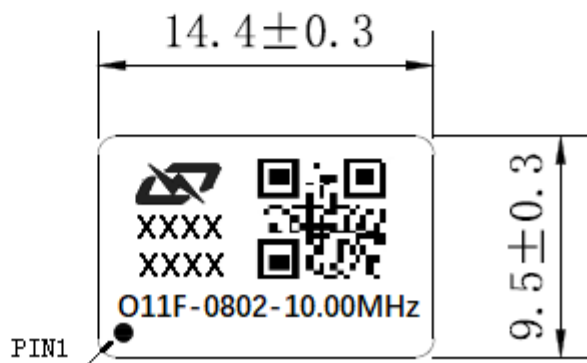

- Note1:** Tolerance $\pm 0.2\text{mm}$ without mark
- Note2:** Referential weight 2.2g
- Note3:** NC is not connect
- Note4:** The first two xx representative: year.
After two xx representative: week.
At last four xxxx representative: serial number.



3. Test Circuit

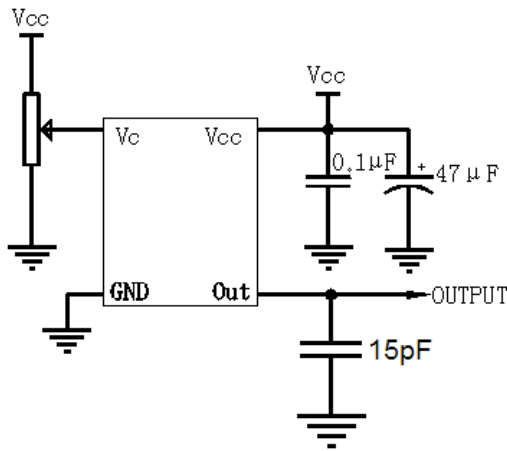

4. Reflow Soldering Curve (RoHS)

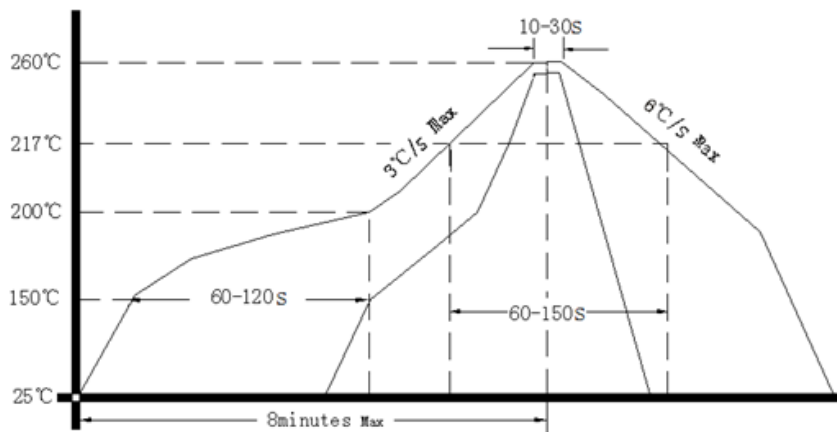

Note: Passing through reflow upside down is not supported

5. Package: Tape & Reel (mm)

