

Customer Code: \_\_\_\_\_

# DATASHEET

DAPU P/N: DPZ2233M333333AA

DAPU			Customer Approval
Drew	Audited	Approved	Stamp, please! Thanks!
Jack	David	William	
Date: 2022.10.14			

## Guangdong Dapu Telecom Technology Co.,Ltd

Building 5, No.24, Industrial East Road, Songshanhu Park, Dongguan, Guangdong, P.R. China

TEL: 0086-0769-88010888 FAX: 0086-0769-81800098



## 1、 Electrical Parameters

**MODEL: DPZ2233M33333AA****For Automotive**

No.	Parameters	SYM.	Electrical Spec.				Notes
			Min.	Typ.	Max.	Units	
1	Standard	-	Conforms to AEC-Q100				
2	Nominal Frequency	FL	33.333333			MHz	
3	Frequency Tolerance	-	-10		+ 10	$\times 10^{-6}$	At 25°C
4	Frequency Stability	-	-90		+ 90	$\times 10^{-6}$	Over Operating Temperature Range
5	Operating Temperature	Topr	-40	~	+ 125	°C	
6	Storage Temperature	Tstg	-55	~	+ 125	°C	
7	Supply Voltage	V <sub>DD</sub>	1.62		3.63	V	
8	Input Current	I <sub>cc</sub>			15	mA	
9	Output waveform	-	CMOS				
10	Output Load	CL	15			pF	
11	Output Voltage High	V <sub>OH</sub>	90%			V <sub>DD</sub>	
12	Output Voltage Low	V <sub>OL</sub>			10%	V <sub>DD</sub>	
13	Rise/Fall Time	T <sub>r</sub> 、 T <sub>f</sub>			5	ns	10%-90% V <sub>DD</sub> Level
14	Aging	-	-3		+ 3	$\times 10^{-6}$	First Year at 25°C
15	Tri-State Output Enable	-	70%			V <sub>DD</sub>	Pin 1, OE
16	Tri-State Output Disable	-			30%	V <sub>DD</sub>	Pin 1, OE
17	Duty Cycle	-	45	~	55	%	
18	Start-Up Time	T <sub>start</sub>			5	ms	Measured from the time V <sub>DD</sub> reaches its rated minimum value



## 2、Mechanical Structure(mm)

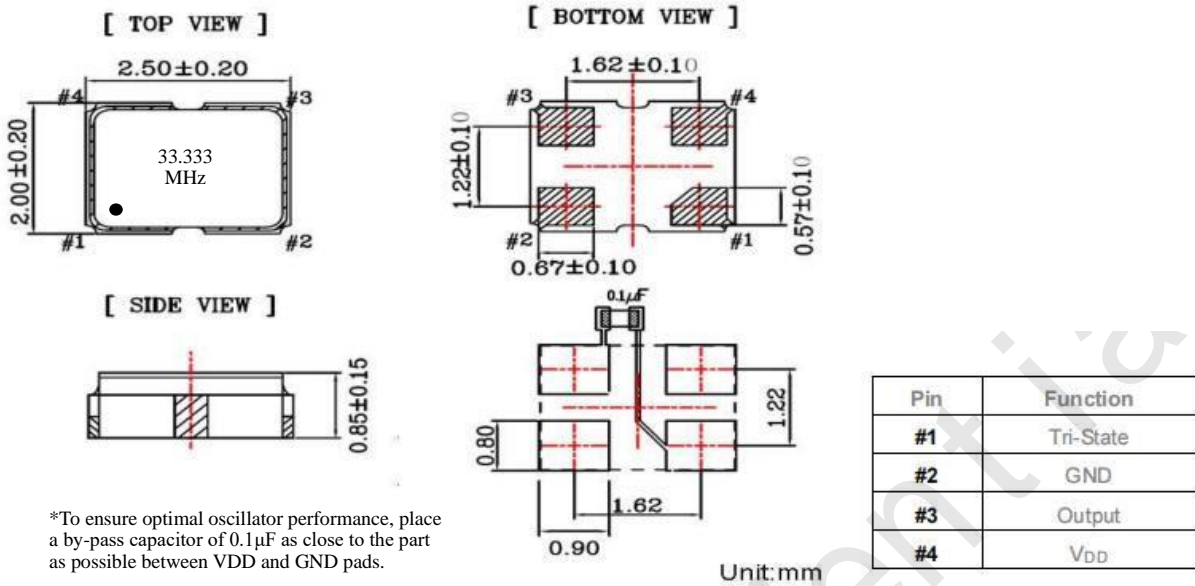

\*To ensure optimal oscillator performance, place a by-pass capacitor of 0.1µF as close to the part as possible between VDD and GND pads.

## 3、Test Circuit

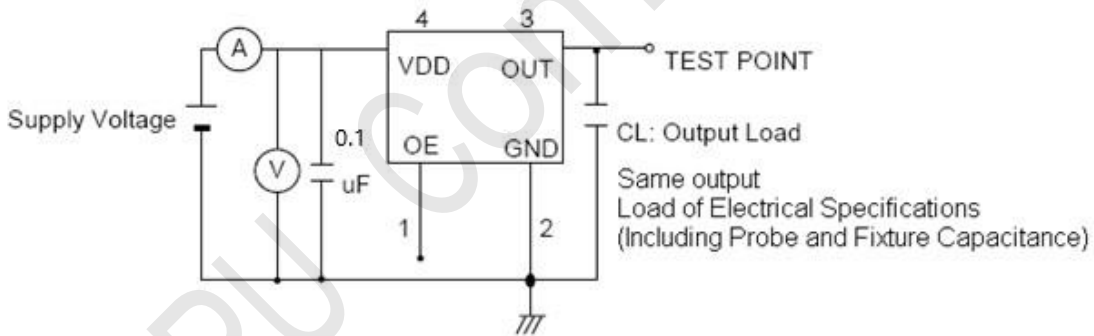

Control input (output enable/disable)

Logic 1 or open on pad 1: Oscillator output

Logic 0 on pad 1 : Disable output to high impedance



### 4、 Reflow Soldering Curve (RoHS)



### 5、 Package: Tape & Reel (mm)

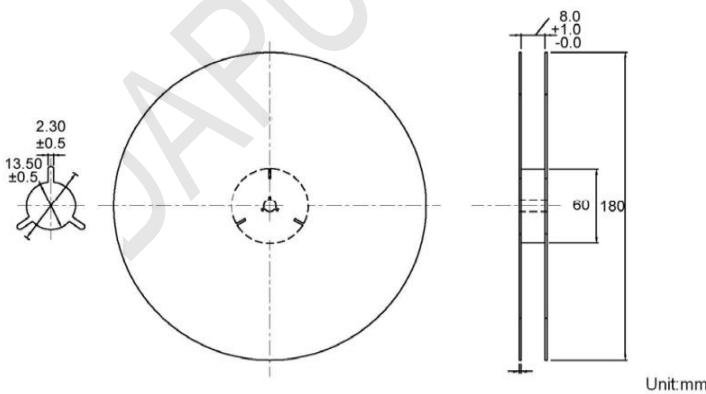
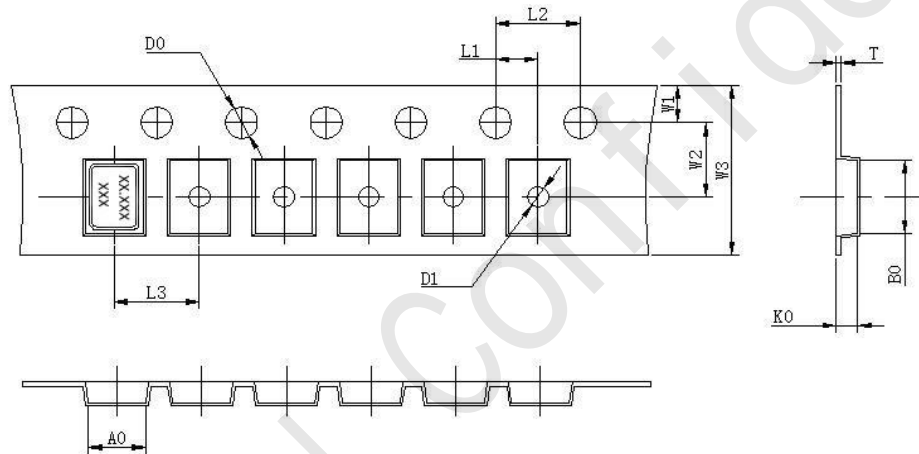

L1	2.00±0.1
L2	4.00±0.1
L3	4.00±0.1
D0	1.55±0.05
D1	1.20±0.5
W1	1.75±0.1
W2	3.50±0.1
W3	8.00±0.2
A0	2.25±0.1
B0	2.7±0.1
K0	1.45±0.1
T	0.25±0.05



## 6、Reliability Test Specification

### 6.1 Reliability Test (Reference AEC-Q100)

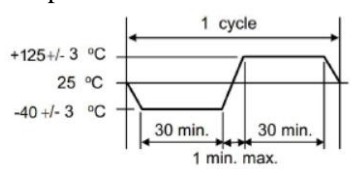
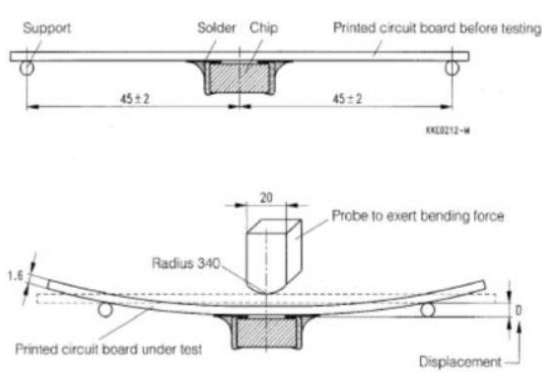
NO.	Test Items	Test Standard	Test Condition	Standard
1	High temperature storage	MIL-STD-202 Method 108	The crystal was placed at a temperature of $125^{\circ}\text{C} \pm 2^{\circ}\text{C}$ for 1000 hours.	A
2	Temperature cycle	JESD22 Method JA-104	Crystal do 1000 cycles according to the table below temperature. 	A
3	Temperature and humidity	MIL-STD-202 Method 103	The crystal is placed for 1000 hours at a temperature of $85^{\circ}\text{C} \pm 2^{\circ}\text{C}$ and a humidity of 85% Time.	A
4	Life span	MIL-STD-202 Method 108	The crystal is placed at a temperature of $125^{\circ}\text{C} \pm 2^{\circ}\text{C}$ for 1000 hours (applied rated VDD).	A
5	shock	MIL-STD-202 Method 213	shock method:half sine wave 100G Duration:6ms Direction:X, Y, Z Axial, 6 faces, 18 shocks in total.	A
6	Vibration	MIL-STD-202 Method 204	Vibration frequency:10~2000Hz Vibration amplitude:1.5mm Scan time:20 min Directions:X, Y, Z (12 cycles in each of the three directions)	A
7	Resistance to soldering heat	MIL-STD-202 Method 210	Reflow soldering: Peak temperature: $260 \pm 5^{\circ}\text{C}$ , time: $10\text{s} \pm 1\text{s}$ .	A
8	Solderability	J-STD-002	Soldering temperature: $245^{\circ}\text{C} \pm 5^{\circ}\text{C}$ Immersion time:5 seconds $\pm 0.5$ seconds Flux:Rosin Resin Methanol Solvent ( 1 : 4 )	B
9	Panel bending	AEC-Q100-005	Apply pressure to the center of the product until it bends to a minimum of 2mm and keep $60 \pm 5$ seconds. 	A

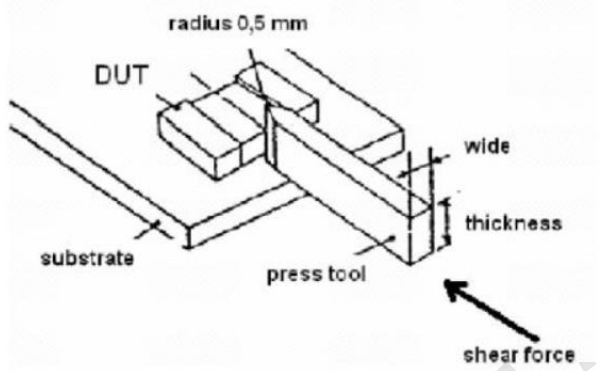

10	Terminal strength	AEC-Q100-006	<p>Apply a force of 1.8Kg laterally for 60±1 seconds.</p> 	A
----	-------------------	--------------	--	---

6.2 Test judgment

Specification	
A	Test after 24±2 hours under normal temperature and normal humidity, and meet Electrical performance requirements.
B	At least 95% of the immersed end is covered with new welding material.