

Travelling Merchant: _____

DATASHEET

Standard: O22B-Q446-10.00MHZ-G289

P/N: _____

Plot			The Label
Drew	Audited	Approved	Stamp, please! Thanks!
Date: 2023.06.13			

Guangdong Dapu Telecom Technology Co.,Ltd

Building 5, No.24, Industrial East Road, Songshanhu Park, Dongguan, Guangdong, P.R. China

TEL: 0086-0769-88010888 FAX: 0086-0769-81800098



1. Electrical Parameters

MODEL: O22B-Q446-10.00MHZ-G289						
Item	Description	Parameters			Unit	Test Condition
		Min.	Typ.	Max.		
Output	Frequency	10.00			MHz	
	Waveform	Sine wave				
	Level	3	5	7	dBm	
	Load	50			Ω	
Frequency Stabilities	Frequency Tolerance vs. Operating Temperature Range	-5		+5	$\times 10^{-9}$	T_A varied from 0°C to 50°C , measurement referenced to frequency observed with $f_{\text{ref}}=(f_{\text{max}}+f_{\text{min}})/2$, $V_{\text{cc}}=12\text{V}$, $O_{\text{load}}=50\Omega$, temperature variable speed less than 2°C per minute.
	Initial Frequency Tolerance	-0.3		+0.3	$\times 10^{-6}$	Measurement referenced to frequency observed with $T_A=25^\circ\text{C}$, $V_{\text{cc}}=12\text{V}$, $V_c=2.5\text{V}$ and after 15 minutes of operation, within 30 days after ex-works.
	Frequency Tolerance vs. supply voltage	-2		+2	$\times 10^{-9}$	measurement referenced to frequency observed $T_A=25^\circ\text{C}$, V_{cc} varied from 11.4V to 12.6V, $V_c=2.5\text{V}$, $O_{\text{load}}=50\Omega$.
	Frequency Tolerance vs. Load	-2		+2	$\times 10^{-9}$	5% Load Change Measurement referenced to frequency observed with $T_A=25^\circ\text{C}$, $V_{\text{cc}}=12\text{V}$, $V_c=2.5\text{V}$, $O_{\text{load}}=50\Omega$.
	Short Term Stability			0.05	$\times 10^{-9}$	Temperature stability, no EMI/EMC or other interference, test after power for 1 hour ref. to 25°C ; 1s.
	Aging Tolerance per day	-1		+1	$\times 10^{-9}$	V_{cc}, V_c, T_A constant Measurement referenced to frequency observed with $T_A=25^\circ\text{C}$, $V_{\text{cc}}=12\text{V}$, $V_c=2.5\text{V}$, $O_{\text{load}}=50\Omega$ and after 30 days of operation.
	Aging Tolerance 1 Year	-0.1		+0.1	$\times 10^{-6}$	
Power Supply	Supply Voltage	11.4	12.0	12.6	V	
	Reference Voltage	4.75	5	5.25	V	
	Current Consumption			125	mA	@ 25°C
	Current Consumption during warm up			300	mA	@ 25°C
	Warm-Up Time			5	minutes	@ 25°C within $\pm 0.1 \times 10^{-6}$ of final frequency with reference after 1 hour on.



Voltage Control Characteristics	Frequency Tuning Range		-1	$\times 10^{-6}$	$V_c=0V$. measurement referenced to $V_c=2.5V$.	
		-0.3	+0.3	$\times 10^{-6}$	$V_c=2.5V$. measurement referenced to exactly 10.00MHz.	
		+1		$\times 10^{-6}$	$V_c=5V$. measurement referenced to $V_c=2.5V$.	
	Linearity		10	%		
	Slope	Positive				
	Input Impedance	100			K Ω	
Phase Noise	Phase Noise @25°C		-110		dBc/Hz	10Hz
			-130			100Hz
			-145			1KHz
			-155			10KHz
Environmental Conditions	Operable Temperature	0	+50	°C		
	Storage Temperature	-55	+105	°C		
	ESD Level	Human Body Model, class2: 2000V to 4000V; ANSI/ESDA/JEDEC JS-001-2010.				
		Machine Model, class B: 200V to 400V; JEDEC JESD22-A115C.				
	Moisture Sensitivity Level	Not humidity sensitive.				
	Vibration	Test Condition: 0.75mm ;acceleration:10g;10Hz~500Hz, one cycle per 30 min, test 2 hour. (3 times for each 3 directions X , Y , Z), IEC 68-2-06 Test Fc.				
Shock	50g; 11ms; half sine wave (3 times for each 3 directions X , Y , Z),IEC 68-2-27 Test Ea/Severity 50A.					



2. Mechanical Structure (mm)

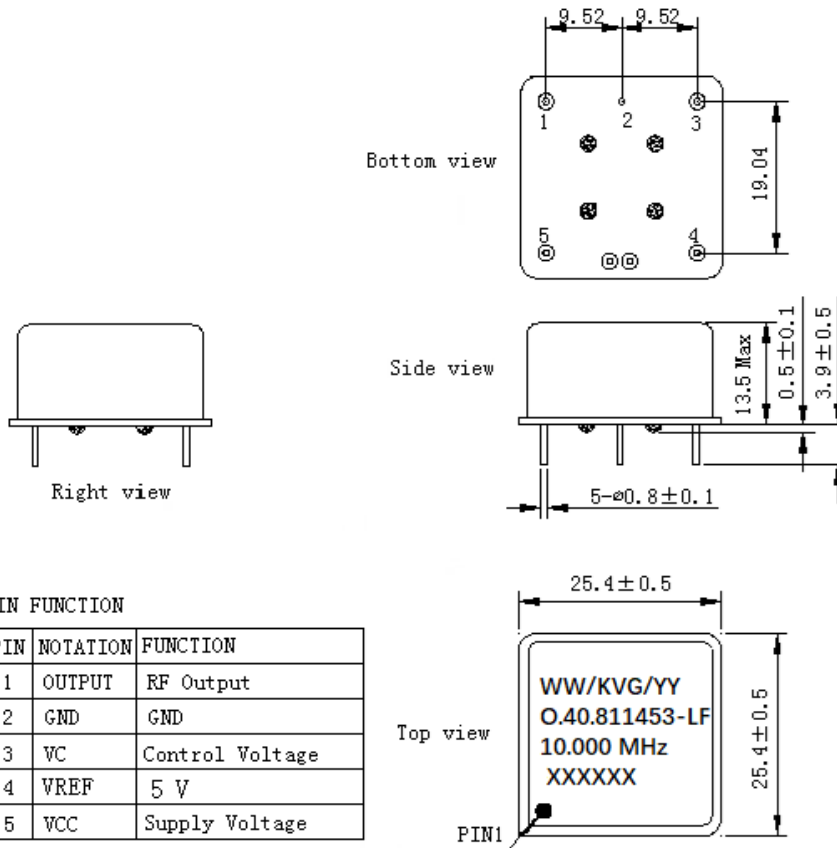

PIN FUNCTION

PIN	NOTATION	FUNCTION
1	OUTPUT	RF Output
2	GND	GND
3	VC	Control Voltage
4	VREF	5 V
5	VCC	Supply Voltage

Note1: Tolerance ± 0.2mm without mark

Note2: The two WW representative: week
After two YY representative: year
The last XXXXXX is serial number

Note3: Referential Weight 13.6g



3. Test Circuit

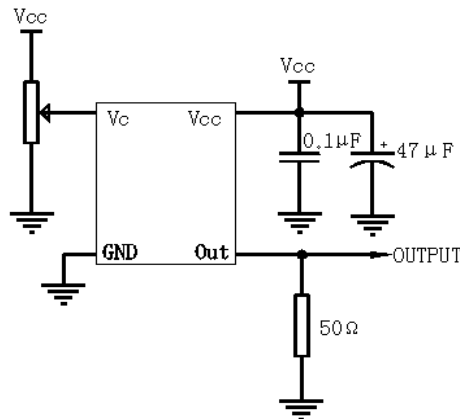

4. Reflow Soldering Curve (RoHS)

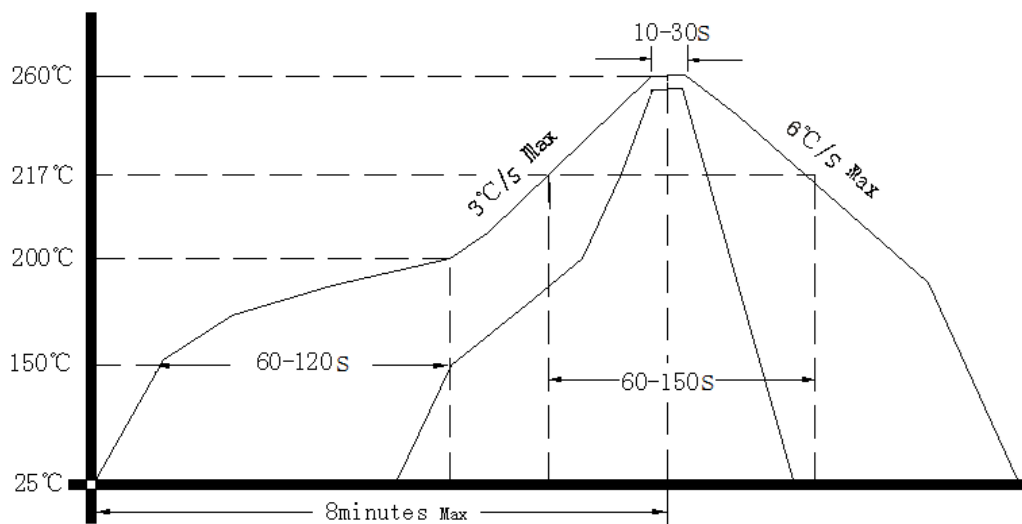

5. Package(mm)

