



Table of amendment

Version	Revision contents	Prepared by	Revised date
1.0	The first issued	<i>Amway</i>	2023.01.31
1.1	The “Frequency Stability vs. Operating Temperature Range” changed	<i>Amway</i>	2023.02.13
1.2	The “Warm Up Time” “Retrace” “Package: Tape & Reel” changed	<i>Amway</i>	2023.02.17
1.3	The “Retrace Accuracy” changed, Add “Overall tolerance over15 years lifetime (df/f0) from nominal frequency”	<i>Amway</i>	2023.02.22
1.4	Del “Initial Frequency Tolerance”, “Overall tolerance over 15 years lifetime (df/f) from 1h post-reflow frequency (f)”changed	<i>Amway</i>	2023.02.23



1. Electrical Parameters

MODEL: O11F-1203-10.00MHz						
Item	Description	Parameters			Unit	Test Condition
		Min.	Typ.	Max.		
Output	Frequency	10.00			MHz	
	Output Waveform	LVCMOS				
	Output Low Voltage			0.4	V	$V_{cc}=3.3V, O_{load}=30pF$
	Output High Voltage	2.4			V	$V_{cc}=3.3V, O_{load}=30pF$
	Duty Cycle	45	50	55	%	@50%
	RF Output Current			4	mA	
	Rise/Fall Time (10%~90%)			5	ns	
	Load			30	pF	
	Start-up time			0.1	sec	@ -40°C~ +85°C
Frequency Stabilities	Overall tolerance over 15 years lifetime (df/f0) from nominal frequency	-4.6		+4.6	$\times 10^{-6}$	After warm-up time including all frequency drift effects (e.g. aging, temperature, reflow shift)
	Overall tolerance over 15 years lifetime (df/f) from 1h post-reflow frequency (f)	-2		+2	$\times 10^{-6}$	After warm-up time including all frequency drift effects
	Frequency Stability vs. Operating Temperature Range	-3		+3	$\times 10^{-9}$	T_A varied from -40°C~85°C, measurement referenced to frequency observed with $f_{ref}=(f_{max}+f_{min})/2, V_{cc}=3.3V, O_{load}=30pF$, temperature variable more than 2°C per minute, after 20 minute of operation, test time ≤ 2 hours, ageing effects are excluded.
	Frequency vs. temperature slope	-0.03		+0.03	$\times 10^{-9}/^{\circ}C$	@ 0°C~ +85°C, temp variation 0.5°C/ min after 2 days of operation
		-0.05		+0.05	$\times 10^{-9}/^{\circ}C$	@ -40°C~ 0°C, temp variation 0.5°C/ min after 2 days of operation
Frequency Stability vs. Supply Voltage	-0.2		+0.2	$\times 10^{-9}$	$3.3V \pm 1\%$, static (5min), $\geq 25^{\circ}C$	



	Aging Tolerance Per Day	-0.05		+0.05	$\times 10^{-6}$	@25°C, after 5 min
		-10		+10	$\times 10^{-9}$	@25°C, after 24 hours
		-2		+2	$\times 10^{-9}$	@25°C, after 7 days
		-1		+1	$\times 10^{-9}$	@25°C, after 30 days
	Aging Tolerance 1 Month	-25		+25	$\times 10^{-9}$	@25°C, after 7 days
		-15		+15	$\times 10^{-9}$	@25°C, after 30 days
	Aging Tolerance 1 Years	-0.2		+0.2	$\times 10^{-6}$	@25°C, after 7 days
		-0.15		+0.15	$\times 10^{-6}$	@25°C, after 30 days
G-sensitivity		0.3	1	$\times 10^{-9}/g$		
Warm Up	Warm Up Time			7	min	@ -40°C~ -10°C within $\pm 50 \times 10^{-9}$ of final frequency with reference after 1 hour on.
				7	min	@ -10°C~ +85°C within $\pm 15 \times 10^{-9}$ of final frequency with reference after 1 hour on.
Retrace	Retrace Accuracy			± 50	$\times 10^{-9}$	@ -40°C~ -10°C, On 24h, Off 24h, On df after warm-up time.
				± 15	$\times 10^{-9}$	@ -10°C~ +85°C On 24h, Off 24h, On df after warm-up time.
				± 5	$\times 10^{-9}$	@ -40°C~ 0°C, On 1h, Off 15min, On df after 40 min on.
				± 5	$\times 10^{-9}$	@ 0°C~ +85°C, On 1h, Off 15min, On df after 25 min on.
				± 150	$\times 10^{-9}$	@ -40°C~ +85°C, Off 10s, On df after 45s on.
Power Supply	Supply Voltage	3.27	3.3	3.33	V	
	Steady Consumption			300	mA	@25°C
					650	mA
Warm up current			800	mA	@ -40°C~ +85°C	
Phase Noise	Phase Noise @ -40 to 85°C			-74	dBc/Hz	1Hz
				-110		10Hz
				-140		100Hz
				-150		1KHz
				-152		10KHz
				-152		100KHz
Spurs And Harmonic	Accumulated Power Of Spurs And Harmonic Distortions			-58		$1 \text{ Hz} \leq f_{\text{Offset}} < 10 \text{ Hz}$
				-83		$10 \text{ Hz} \leq f_{\text{Offset}} < 100 \text{ Hz}$
				-98		$100 \text{ Hz} \leq f_{\text{Offset}} < 1 \text{ K Hz}$



	@-40 to 85°C			-98		$1\text{KHz} \leq f_{\text{Offset}} \leq 10\text{ kHz}$	
				-78		$10\text{ kHz} \leq f_{\text{Offset}}$	
Environmental Conditions	Operating Temperature Range	-40		+85	°C		
	Operable Temperature Range	-45		+90	°C		
	Rate Of Temperature Variation			2	°C/min		
	Relative Humidity Range	5		95	%		
	Absolute Humidity Range	1		29	g/m ³		
	Air pressure range	70		106	kPa		
	ESD Level	Human Body Model, class2: 2000V to 4000V; ANSI/ESDA/JEDEC JS-001-2010.					
		Machine Model, class B: 200V to 400V; JEDEC JESD22-A115C.					
	Moisture Sensitivity Level	Level 2.					
	Vibration	<p>Three-dimensional vibration, sinusoidal according to EN 300 019-2-4 Class 4M5 with amplitude modified by a gain of 10.</p> <ul style="list-style-type: none"> • Amplitude of displacement: 12mm (5-9Hz) • Amplitude of acceleration: 40 m/ s² (9-200Hz) 					
Shock	<p>Pretest sine sweep vibration testing of all axes based on IEC 60068-2-6 (test Fc), with the following parameter severities:</p> <ul style="list-style-type: none"> • Amplitude of displacement: $\geq 0.75\text{mm}$ (0.3-9Hz) • Frequency range: 0.3Hz to 50Hz • Amplitude of acceleration: $\geq 2\text{ m/ s}^2$ <p>or simulation of mechanical resonances for:</p> <ul style="list-style-type: none"> • Frequency range: 0.3Hz to 50Hz <p>Pretest result:</p> <ul style="list-style-type: none"> • Vibration testing/ simulation doesn't exhibit any resonance <p>Shock per EN 300 019-2-4 Class 4M5 with amplitude modified by a gain of 1.5.</p> <ul style="list-style-type: none"> • Amplitude of acceleration: 75 m/ s² <p>Device shall be operating after the shock event.</p> <ul style="list-style-type: none"> • Frequency shift $df/f \leq 10\text{ ppb}$ 						
Full Package Storage	Relative humidity (%)	20% ~ 70%					
	Temperature (°C)	-10~35°C					



2. Phase Stability In Holdover

Profile 1: Ramp with 0.5°C/min to max or min temperature at the beginning, constant for rest of time.

Profile 2: Continuous temperature cycling with 0.5°C/min between min and max temperatures.

For any temperature in the given range, with temperature variation such temperature remains in that range

Phase stability	Ambient temperature	Condition
99% probability all clauses	-40°C to +85°C	After 7 days of continuous operation/ ageing Supply voltage stability ± 0.1%, load 15pF
≤ ± 1.5 µsec over 4 h	± 5°C interval ± 5°C interval	Profile 1 Profile 2
≤ ± 1.5 µsec over 2 h	± 20°C interval ± 20°C interval	Profile 1 Profile 2

3. Mechanical Structure (mm)

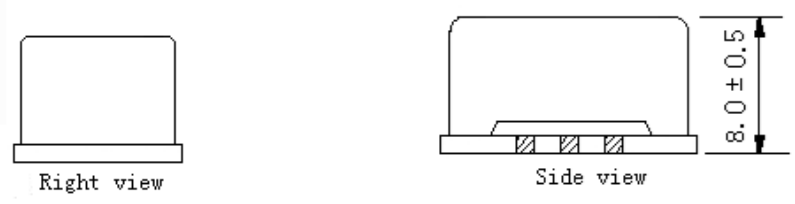
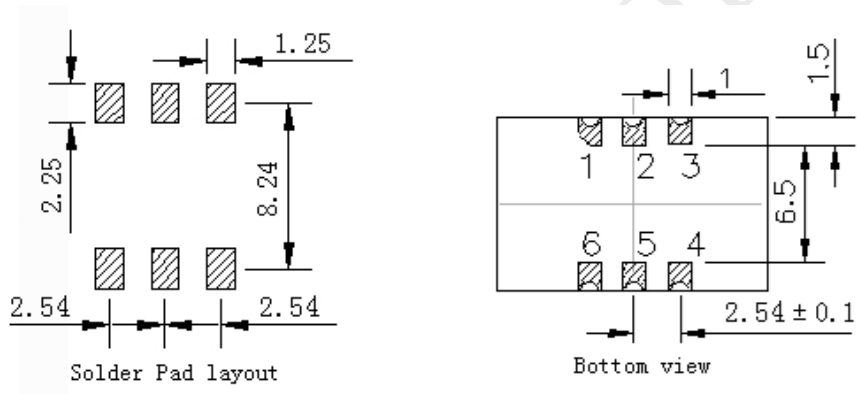

PIN FUNCTION

PIN	NOTATION	FUNCTION
1	NC	Not Connect
2,5	NC	Not Connect
3	GND	GND
4	OUTPUT	RF Output
6	VCC	Supply Voltage

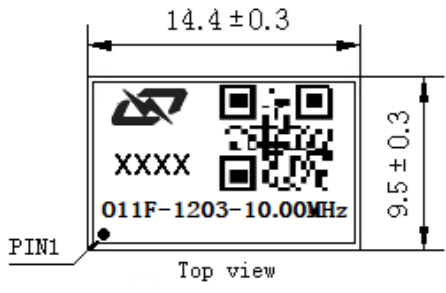

- Note1:** Tolerance ± 0.2mm without mark
- Note2:** The first two xx representative: week
After two xx representative: year
- Note3:** Referential weight 2g



4. Test Circuit

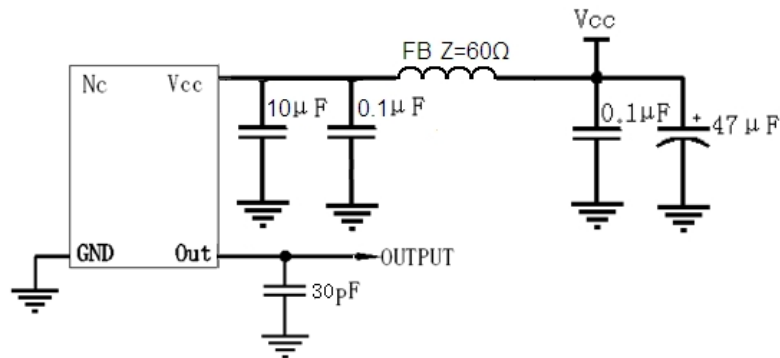

5. Reflow Soldering Curve (RoHS)

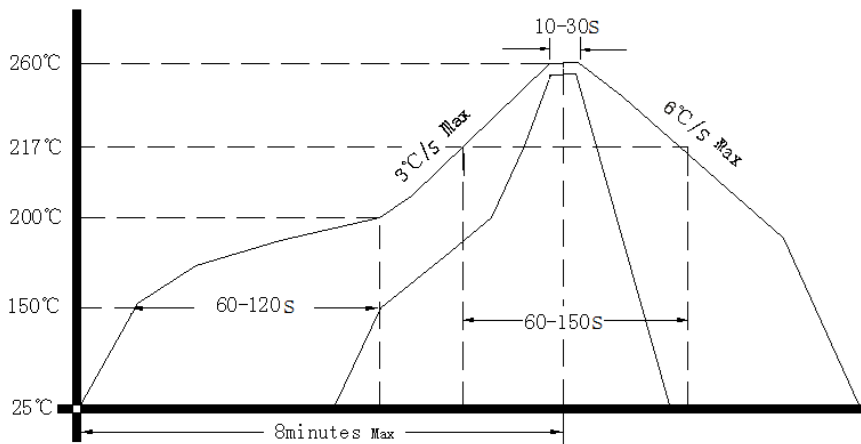

Passing through reflow upside down is not supported

6. Package: Tape & Reel (mm)

