

Customer Code : \_\_\_\_\_

# DATASHEET

DAPU P/N : **O11D-S321-38.40MHz-G025**

Customer P/N: \_\_\_\_\_

DAPU			Customer Approval
Drew	Audited	Approved	Stamp, please! Thanks!
Date: 2023.05.10			

## Guangdong Dapu Telecom Technology Co.,Ltd

Building 5, No.24, Industrial East Road, Songshanhu Park, Dongguan, Guangdong, P.R. China

TEL: 0086-0769-88010888 FAX: 0086-0769-81800098





## 1. Electrical Parameters

MODEL: O11D-S321-38.40MHz-G025						
Item	Description	Parameters			Unit	Test Condition
		Min.	Typ.	Max.		
Output	Frequency	38.40			MHz	
	Output Waveform	LVCMOS				
	Output Low Voltage			0.4	V	$V_{cc}=5V, O_{load}=15pF$
	Output High Voltage	2.4			V	$V_{cc}=5V, O_{load}=15pF$
	Duty Cycle	45		55	%	@50%
	Rise / Fall Time (10%~90%)			8	ns	
	Start up Time			0.5	s	
	Spurious			-70	dBc	
	Load	15			pF	
Frequency Stabilities	Frequency Tolerance vs. Operating Temperature Range	-0.02		+0.02	$\times 10^{-6}$	$T_A$ varied from $-40^{\circ}C$ to $85^{\circ}C$ , measurement referenced to frequency observed with $f_{ref}=(f_{max}+f_{min})/2$ , $V_{cc}=5V$ , $O_{load}=15pF$ , temperature variable speed less than $2^{\circ}C$ per minute.
	Initial Frequency Tolerance	-0.2		+0.2	$\times 10^{-6}$	Measurement referenced to frequency observed with $T_A=25^{\circ}C$ , $V_{cc}=5V$ , $V_c=1.65V$ , and after 15 minutes of operation, within 30 days after ex-works.
	Frequency Tolerance vs. Supply Voltage	-2		+2	$\times 10^{-9}$	measurement referenced to frequency observed $T_A=25^{\circ}C$ , $V_{cc}$ varied from 4.75V to 5.25V, $V_c=1.65V$ and $O_{Load}=15pF$ .
	Frequency Tolerance vs. Load	-2		+2	$\times 10^{-9}$	10% load change measurement referenced to frequency observed with $T_A=25^{\circ}C$ , $V_{cc}=5V$ , $V_c=1.65V$ , and $O_{Load}=15pF$ .
	G-Sensitivity		1		$\times 10^{-9}/g$	Per axis
	Short Term Stability			0.05	$\times 10^{-9}$	Temperature stability, no EMI\EMC or other interference, test after power for 1hour ref. to $25^{\circ}C$ ; 1s.
	Aging Tolerance Per Day	-2		+2	$\times 10^{-9}$	$V_{cc}, V_c, T_A$ constant measurement referenced to frequency observed with
	Aging Tolerance First Year	-0.2		+0.2	$\times 10^{-6}$	$T_A=25^{\circ}C$ , $V_{cc}=5V$ , $V_c=1.65V$ , and after 30 days of operation.



Power Supply	Supply Voltage	4.75	5	5.25	V	
	Voltage Reference	3.21	3.3	3.39	V	
	Voltage Reference vs. temperature	-4		+4	mV	T <sub>A</sub> varied from -40°C to 85°C, measurement referenced to 25°C
	Steady Consumption			150	mA	@25°C
	Warm up current			400	mA	
	Warm-Up Time			2	min	@25°C, within ±0.1×10 <sup>-6</sup> of final frequency with reference after 1 hour on.
Voltage Control Characteristics	Frequency Tuning Range	-3		-1	×10 <sup>-6</sup>	V <sub>c</sub> =0V. measurement referenced to V <sub>c</sub> =1.65V
		-0.2		+0.2	×10 <sup>-6</sup>	V <sub>c</sub> =1.65V. measurement referenced to Exactly38.40MHz
		+1		+3	×10 <sup>-6</sup>	V <sub>c</sub> =3.3V. measurement referenced to V <sub>c</sub> =1.65V
	Linearity			10	%	
	Slope	Positive				
	Input Impedance	100			KΩ	
Phase Noise	Phase Noise			-103	dBc/Hz	10Hz
				-130		100Hz
				-140		1KHz
				-150		10KHz
				-155		100KHz
				-155		1MHz
Environmental Conditions	Operable Temperature	-40		+85	°C	
	Storage Temperature	-55		+105	°C	
	ESD Level	Human Body Model, class2: 2000V to 4000V; ANSI/ESDA/JEDEC JS-001-2010.				
		Machine Model, class B: 200V to 400V; JEDEC JESD22-A115C.				
	Moisture Sensitivity Level	Not humidity sensitive.				
	Vibration	Test Condition: 0.75mm ;acceleration:10g;10Hz~500Hz, one cycle per 30 min, test 2 hour. (3 times for each 3 directions X , Y , Z), IEC 68-2-06 Test Fc.				
Shock	50g; 11ms; half sine wave (3 times for each 3 directions X, Y, Z), IEC 68-2-27 Test Ea/Severity 50A.					
Full Package Storage	Relative humidity (%)	20%~70%				
	Temperature (°C)	-10~35°C				



## 2. Mechanical Structure (mm)

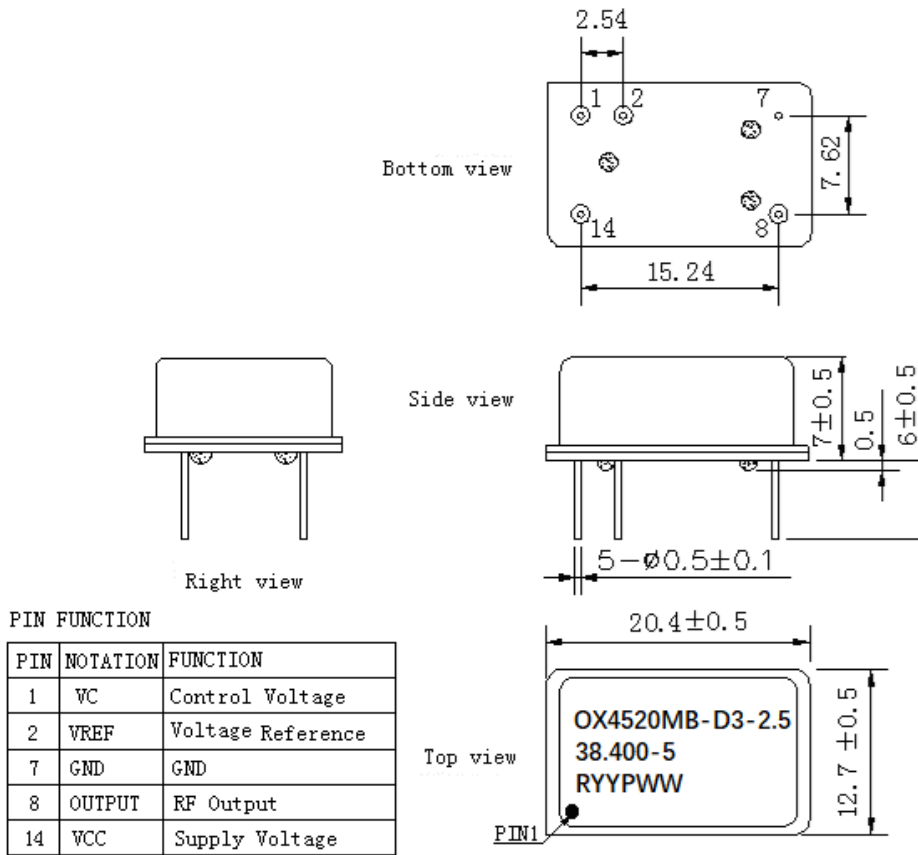

### PIN FUNCTION

PIN	NOTATION	FUNCTION
1	VC	Control Voltage
2	VREF	Voltage Reference
7	GND	GND
8	OUTPUT	RF Output
14	WCC	Supply Voltage

- Note1:** Tolerance  $\pm 0.2\text{mm}$  without mark
- Note2:** The first two YY representative: year  
After two WW representative: week
- Note3:** Referential weight 4.2g
- Note4:** NC is not connect



### 3. Test Circuit

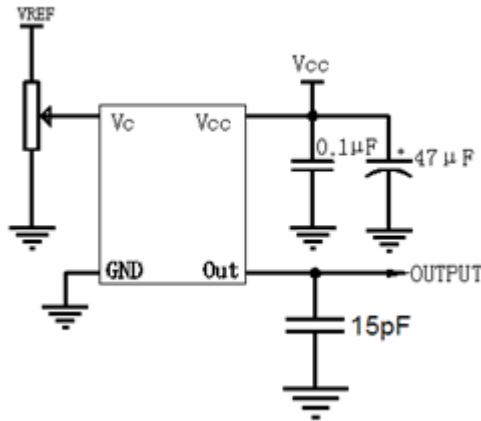

### 4. Reflow Soldering Curve (RoHS)

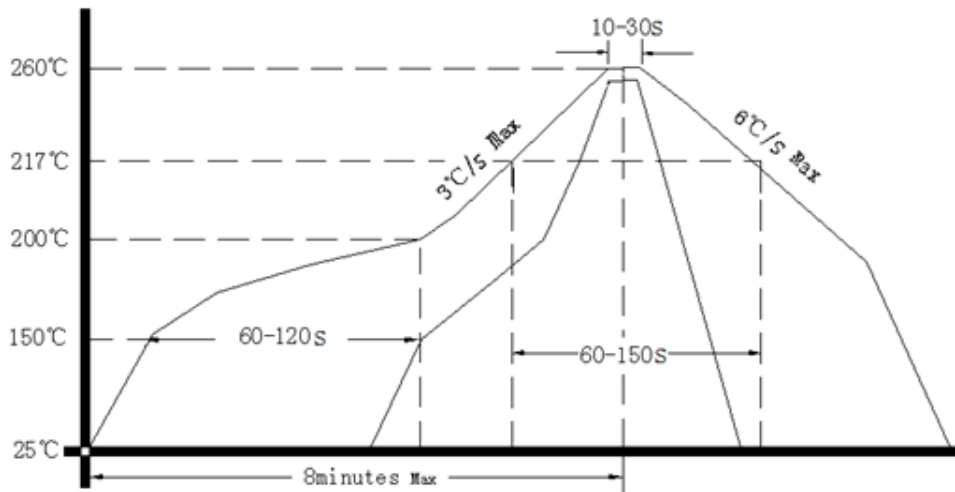

Note: Passing through reflow upside down is not supported

### 5. Package: Tape & Reel (mm)

