





## 1、Electrical Parameters

MODEL: JDPDE2000001							
No.	Parameters	SYM.	Electrical Spec.				Notes
			Min.	Typ.	Max.	Units	
1	Nominal Frequency	FL	200.0			MHz	
2	Output Waveform		LVDS				
3	Vibration Mode		3rd				
4	Total Stability	$\Delta f/f_n$	-30		+30	ppm	Frequency tolerance@25°C and frequency stability vs. operating temperature range and voltage and 1year aging.
5	Operating Temperature	T-opr	-40	+25	+85	°C	
6	Storage Temperature	T-stg	-55	~	+125	°C	
7	Supply Current	I <sub>cc</sub>			60	mA	
8	Start up Time	T <sub>start</sub>			10	ms	
9	Rise/Fall Time	T <sub>r</sub> 、T <sub>f</sub>			0.4	ns	20%~80%
10	Duty Cycle	DC	45		55	%	@V <sub>DD</sub> -1.3V
11	Supply Voltage	V <sub>DD</sub>	1.62	1.8	1.98	V	
12	Maximum Supply Voltage Range	V <sub>DD</sub>	-0.5		5.0	V	
13	“H” Input Voltage	V <sub>IH</sub>	0.7V <sub>DD</sub>			V	
14	“L” Input Voltage	V <sub>IL</sub>			0.3V <sub>DD</sub>	V	
15	E/D	Logic “1”or Floating input, Outputs enable, logic “0”, Outputs disable.					
16	Output Voltage “H”Level	V <sub>OH</sub>			1.6	V	100±1Ω (R1+R1 between OUT-OUTN)
17	Output Voltage “L”Level	V <sub>OL</sub>	0.9			V	
18	Aging		-3		+3	ppm	1 <sup>st</sup> year@25°C
19	Phase Jitter	RMS			0.2	ps	12kHz ~ 20MHz



## 2、Mechanical Structure(mm)

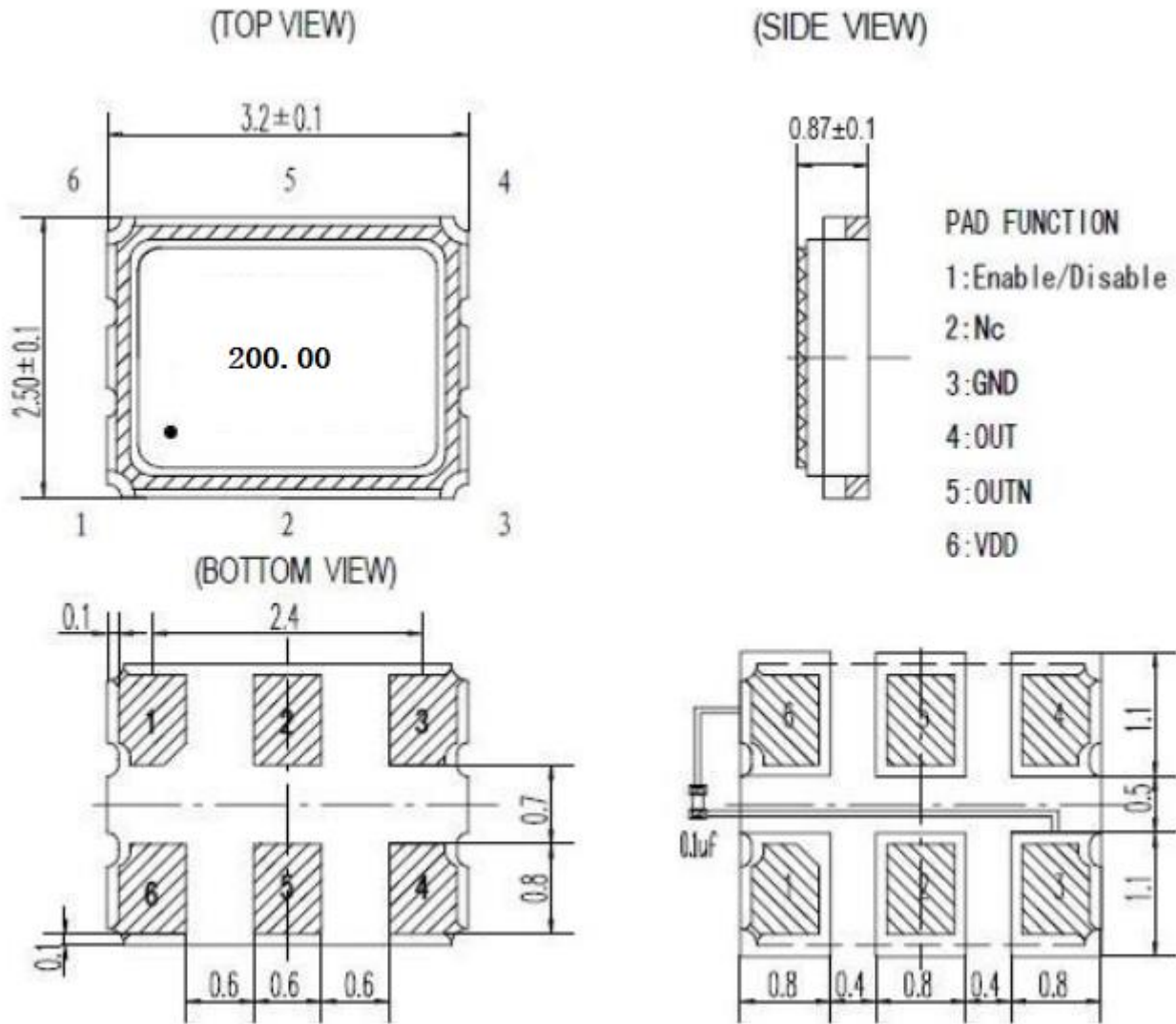

## 3、TEST CIRCUIT

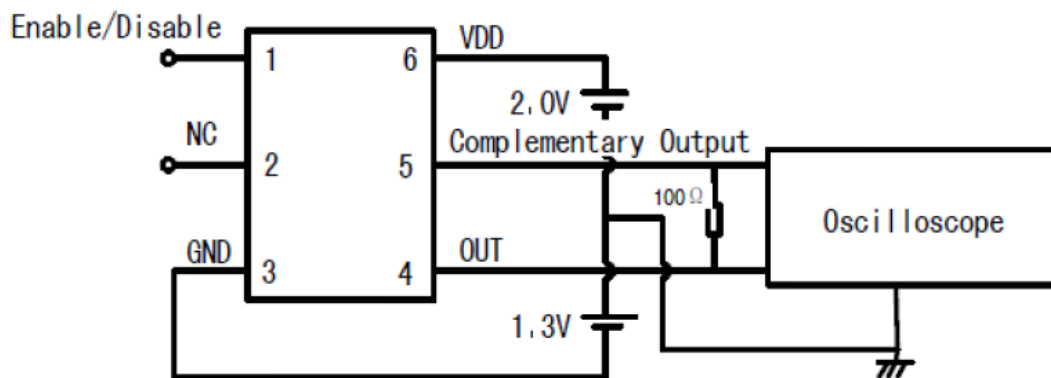



### 4、 Reflow Soldering Curve (RoHS)

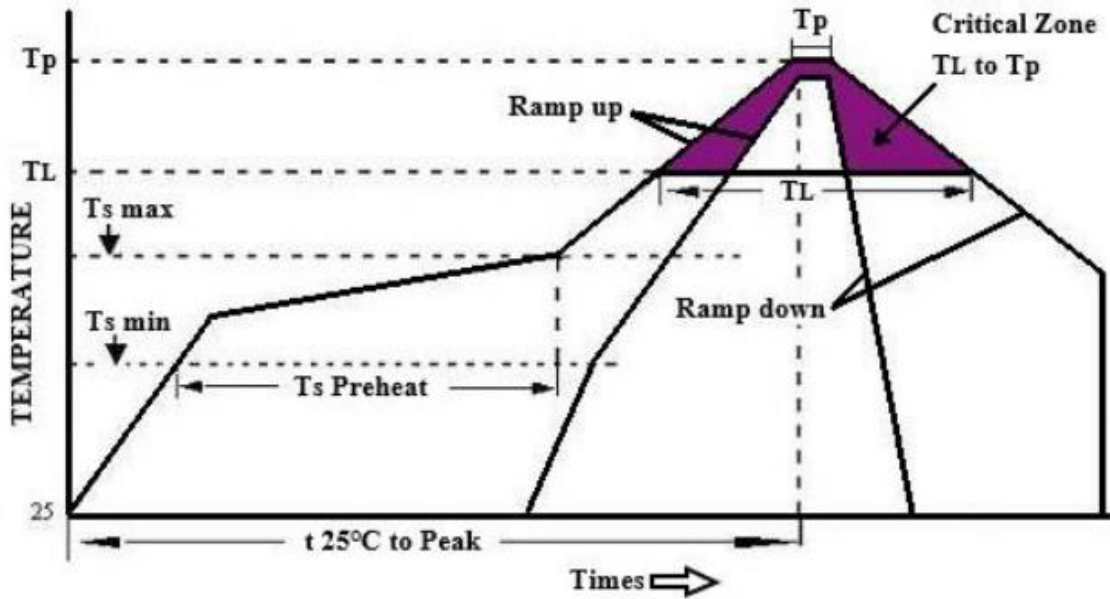

#### High Temperature Infrared /Convection

Note:Temperature shown are applied to body of device

Ts max to TL(Ramp-up Rate)	3°C/second max
Preheat	
Temperature Min(Ts Min)	150°C
Temperature Typical( Ts Typ)	175°C
Temperature Max.(Ts Max)	200°C
Time(ts)	60-180 seconds
Ram-up Rate(TL to Tp)	3°C/second Max
Time Maintained Above:	
--Temperature(TL)	217°C
--Time(TL)	60-150seconds
Peak Temperature (Tp)	260°C Max for 10 seconds
Time within 5°C of actual peak(tp)	20-40 seconds
Ramp-down Rate	6°C/seconds Max
Tune 25°C to Peak Temperature(t)	8 minutes Max
Moisture Sensitivity Level	Level 1

#### High Temperature Manual Soldering

Note:Temperature shown are applied to body of device



## 5、 Package: Tape & Reel (mm)

### 1. Dimensions of Carrier Tape

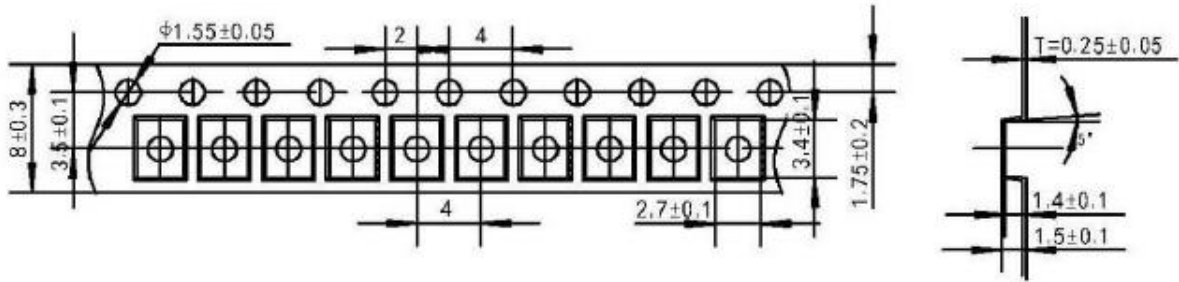

### 2. Dimensions of Reel

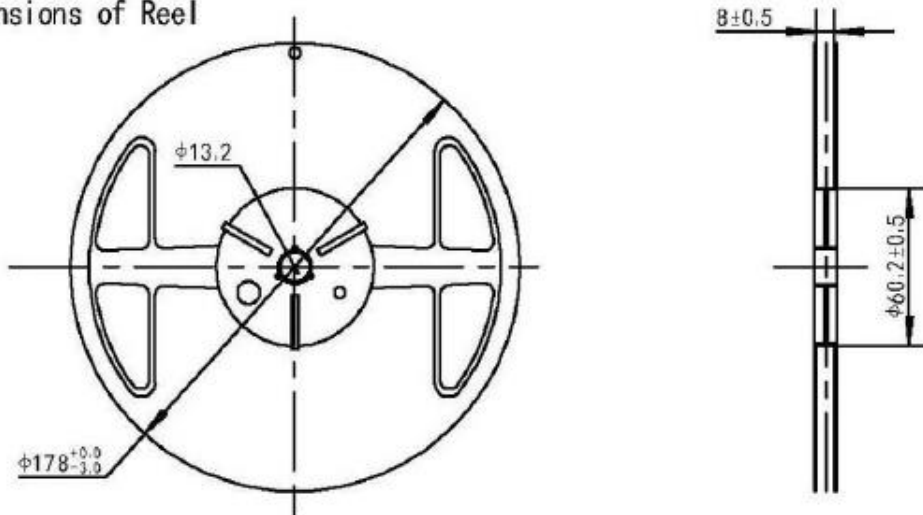

### 3. Packing

1 reel/box 1 reel=3000pcs

10 boxes/carton (the carton with bubble pad on four sides)

