

Customer Code : _____

DATASHEET

DAPU P/N: **O22S-K445-10.00MHz**

Customer P/N: _____

DAPU			Customer Approval
Drew	Audited	Approved	Stamp, please! Thanks!
Date: 2022.11.08			

Guangdong Dapu Telecom Technology Co.,Ltd

Building 5, No.24, Industrial East Road, Songshanhu Park, Dongguan, Guangdong, P.R. China

TEL: 0086-0769-88010888 FAX: 0086-0769-81800098



Table of amendment

Version	Revision contents	Prepared by	Revised date
1.0	The first issued	<i>Amway</i>	2020.08.11
1.1	The “Mechanical Structure” changed	<i>Amway</i>	2021.03.01
1.2	Add “Tuning Sensitivity”	<i>Amway</i>	2021.08.04
1.3	The “Modulation Bandwidth” “Reflow Soldering Curve” changed	<i>Amway</i>	2022.04.13
1.4	The “Note2” changed	<i>Amway</i>	2022.05.31
1.5	The “Modulation Bandwidth” changed	<i>Amway</i>	2022.06.29
1.6	The “Moisture Sensitivity Level” changed	<i>Amway</i>	2022.11.08



1. Electrical Parameters

MODEL: O22S-K445-10.00MHz						
Item	Description	Parameters			Unit	Test Condition
		Min.	Typ.	Max.		
Output	Frequency	10.00			MHz	
	Output Waveform	Sine wave				
	Level	5		10	dBm	
	Load	50			Ω	
	Harmonics Suppression			-20	dBc	Except 9-11MHz
	Spurious Suppression			-90	dBc	At frequency range 9-11MHz
Reference Voltage Output	Reference Voltage	4.925	5	5.075	V	
	Internal Resistance			100	Ω	
Alarm Output	Alarm Level	0		0.4	V	
	Ready Level	2.4		3.6	V	
	Load Current			100	μ A	
Frequency Stabilities	Frequency Tolerance vs. Operating Temperature Range	-0.05		+0.05	$\times 10^{-6}$	T_A varied from -20°C to 75°C , measurement referenced to frequency observed with $f_{\text{ref}}=(f_{\text{max}}+f_{\text{min}})/2$, $V_{\text{cc}}=10.5\text{V}\sim 12.6\text{V}$, $V_{\text{c}}=2.5\text{V}$, $O_{\text{load}}=50\Omega$, temperature variable speed less than 2°C per minute.
	Initial Frequency Tolerance	-0.1		+0.1	$\times 10^{-6}$	Measurement referenced to frequency observed with $T_A=25^{\circ}\text{C}$, $V_{\text{cc}}=10.5\text{V}\sim 12.6\text{V}$, $V_{\text{c}}=2.5\text{V}$, and after 15 minutes of operation, within 30 days after ex-works.
	Frequency Tolerance vs. supply voltage	-5		+5	$\times 10^{-9}$	measurement referenced to frequency observed $T_A=25^{\circ}\text{C}$, $V_{\text{cc}}=10.5\text{V}\sim 12.6\text{V}$, $V_{\text{c}}=2.5\text{V}$, $O_{\text{load}}=50\Omega$.
	Frequency Tolerance vs. Load	-5		+5	$\times 10^{-9}$	5% Load Change Measurement referenced to frequency observed with $T_A=25^{\circ}\text{C}$, $V_{\text{cc}}=10.5\text{V}\sim 12.6\text{V}$, $V_{\text{c}}=2.5\text{V}$, $O_{\text{load}}=50\Omega$.
	Orientation	-0.01		+0.01	$\times 10^{-6}$	
	Short-Term Stability: Allan Variance				0.5	$\times 10^{-9}$
				0.1	$\times 10^{-9}$	Temperature stability, no EMI\EMC or other interference, test after power for 1hour ref. to 25°C ; 10s.
				1	$\times 10^{-9}$	Temperature stability, no EMI\EMC or other interference, test after power for 1hour ref. to 25°C ; 100s.



	Aging Tolerance Per Day	-1		+1	$\times 10^{-9}$	V _{cc} , V _c , T _A constant Measurement referenced to frequency observed with T _A =25°C, V _{cc} =10.5V~12.6V, V _c =2.5V, O _{load} =50Ω and after 30 days of operation.
	Aging Tolerance Per 30 Day	-0.02		+0.02	$\times 10^{-6}$	
	Aging Tolerance Per Year	-0.1		+0.1	$\times 10^{-6}$	
	Aging Tolerance 15 Year	-1		+1	$\times 10^{-6}$	
	Retrace			0.02	$\times 10^{-6}$	@25°C after 24hours power on/2 hours off/1 hour power on.
Power Supply	Supply Voltage	10.5	12.0	12.6	V	
	Steady Consumption			400	mA	@-20°C
				340	mA	@25°C
				380	mA	@0°C
	Warm up current			400	mA	
Warm-Up Time			10	min		
Voltage Control Characteristics	Frequency Tuning Range	-1.5		-0.8	$\times 10^{-6}$	V _c =0V. measurement referenced to V _c =2.5V
		-0.1		+0.1	$\times 10^{-6}$	V _c =2.5V. measurement referenced to exactly 10.00MHz
		+0.8		+1.5	$\times 10^{-6}$	V _c =5.0V. measurement referenced to V _c =2.5V
	Tuning Sensitivity	±0.32		±0.6	ppm/V	V _c =0V~5V
	Modulation Bandwidth	3			Hz	
	Linearity			10	%	
	Slope	Positive				
	Input Impedance	100			KΩ	
Phase Noise	Phase Noise @25°C			-80	dBc/Hz	1Hz
				-110		10Hz
				-135		100Hz
				-145		1KHz
				-150		10KHz
				-150		100KHz
				-150		100KHz
Environmental Conditions	Operating Temperature	-20		+75	°C	
	Operable Temperature	-30		+80	°C	
	Storage Temperature	-55		+105	°C	
	ESD Level	Human Body Model, class2: 2000V to 4000V; ANSI/ESDA/JEDEC JS-001-2010. Machine Model, class B: 200V to 400V; JEDEC JESD22-A115C.				



	Moisture Sensitivity Level	Level 1.
	Vibration	Test Condition: 0.75mm ;acceleration:10g;10Hz~500Hz, one cycle per 30 min, test 2 hour. (3 times for each 3 directions X ,Y , Z), IEC 68-2-06 Test Fc.
	Shock	50g; 11ms; half sine wave (3 times for each 3 directions X ,Y, Z),IEC 68-2-27 Test Ea/Severity 50A.
Air pressure	Operating	54kPa(equiv.5000m)
	Non operating	26kPa(equiv.10000m)
MTBF	@100% operating time and 45°C ambient temperature [hours] >100 000	
Full Package Storage	Relative humidity (%)	20%~70%
	Temperature (°C)	-10~35°C



2. Mechanical Structure (mm)

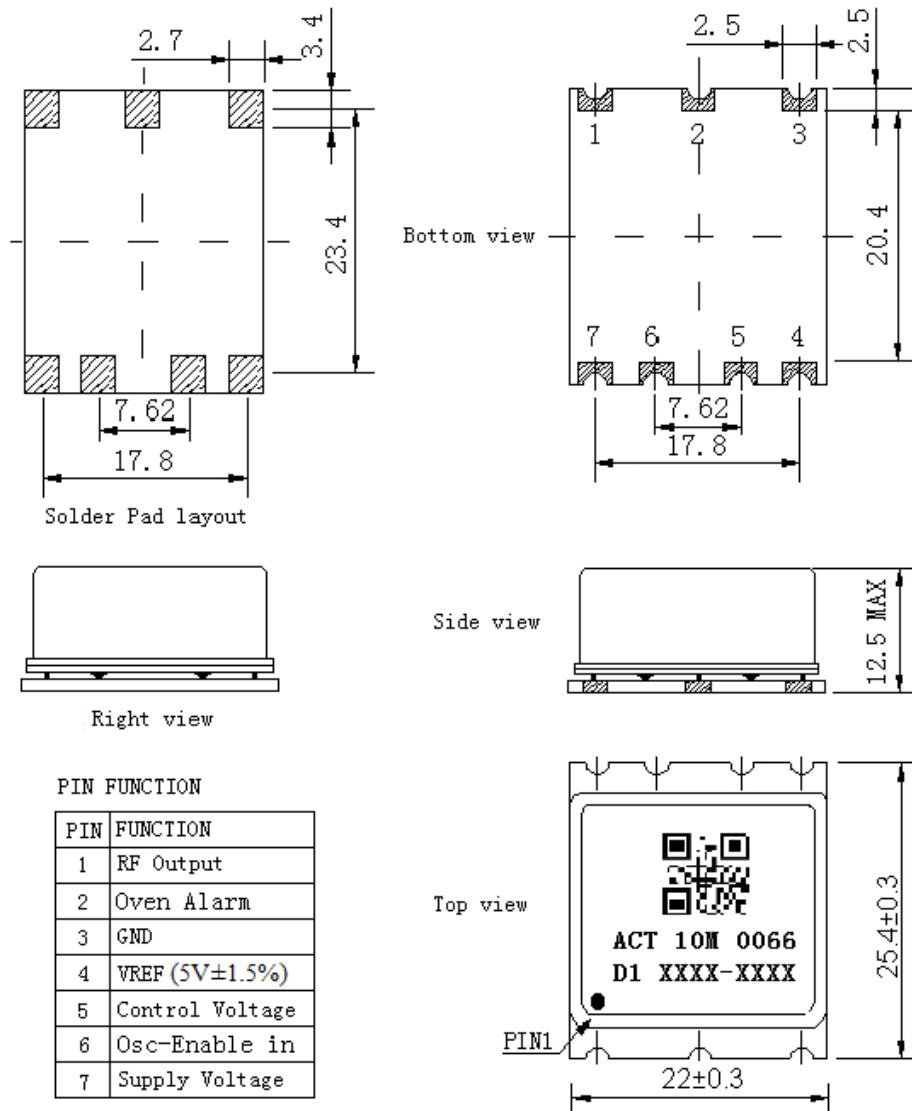

Note1: Tolerance $\pm 0.20\text{mm}$ without mark

Note2: The first two xx representative: week
After two xx representative: year
At last four xxxx representative: serial number

Note3: Referential Weight 10g

Note4: Instruction of Pin 6:

- 1): Oscillator must be switched ON with high signal: TTL/CMOS/HCMOS compatible input.
- 2): High level up to 12.6V, high level min 2.4V, must be acceptable. The input impedance $\geq 100\text{ K}\Omega$.
- 3): When the voltage is between 2.4V and 12.6V, the RF output pin needs to output a signal between 5dBm and 10dBm.
- 4): When the voltage is 0 ~ 2.4V, the RF output pin cannot have signal output.
- 5): With OSC-enable = low (0 ~ 2.4V) the internal oscillator is not oscillating. It is totally switched off.
- 6): If Osc-Enable function is not used, Pin6 must be connected to Pin7.



3. Test Circuit

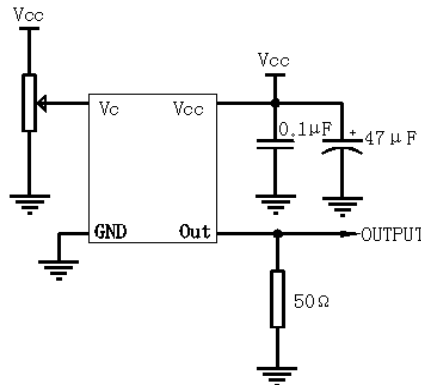

4. Reflow Soldering Curve (RoHS)

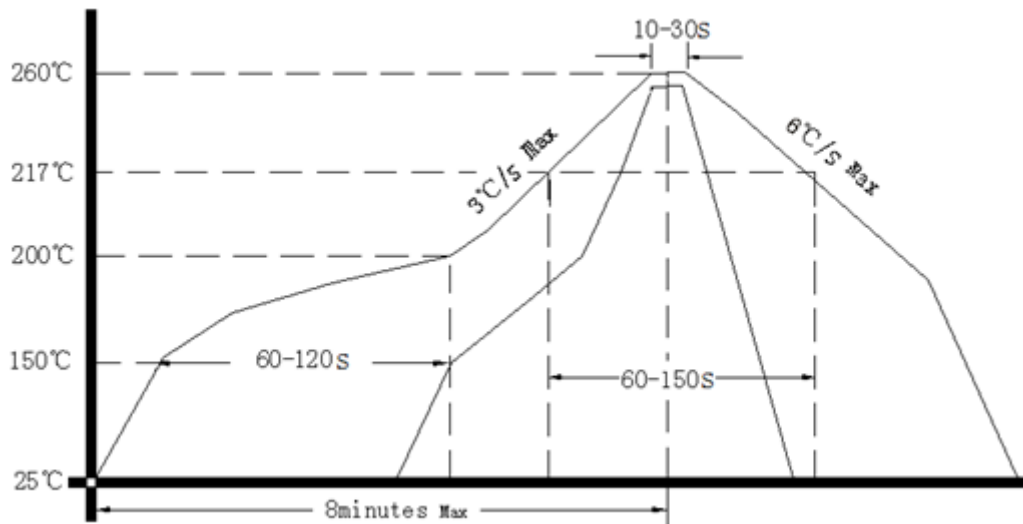

Note: Passing through reflow upside down is not supported

5. Package: Tape & Reel (mm)

