



1. Electrical Parameters

MODEL: PCN-O22S-0802-10.00MHz						
Item	Description	Parameters			Unit	Test Condition
		Min.	Typ.	Max.		
Output	Frequency	10.00			MHz	
	Output Waveform	LVCMOS				
	Output Low Voltage			0.4	V	$V_{cc}=3.3V, O_{load}=15pF$
	Output High Voltage	2.8			V	$V_{cc}=3.3V, O_{load}=15pF$
	Duty Cycle	45	50	55	%	@50%
	Rise / Fall Time (10%~90%)			5	ns	
	Load	15			pF	
	Start-up Time			0.5	s	
	Spurious			-70	dBc	
	Overshoot			10	%	$O_{load}=15pF$
Frequency Stabilities	Frequency Tolerance vs. Operating Temperature Range			6	$\times 10^{-9}$	T_A varied from $-10^{\circ}C$ to $70^{\circ}C$, $V_{cc}=3.3V$, $V_c=1.65V$, $O_{load}=15pF$, temperature variable speed less than $2^{\circ}C$ per minute. calculation formula : $(f_{max}-f_{min})/f_0$.
				10	$\times 10^{-9}$	T_A varied from $-40^{\circ}C$ to $85^{\circ}C$, $V_{cc}=3.3V$, $V_c=1.65V$, $O_{load}=15pF$, temperature variable speed less than $2^{\circ}C$ per minute. calculation formula : $(f_{max}-f_{min})/f_0$.
				0.1	$\times 10^{-6}$	T_A varied from $-40^{\circ}C$ to $90^{\circ}C$, $V_{cc}=3.3V$, $V_c=1.65V$, $O_{load}=15pF$, temperature variable speed less than $2^{\circ}C$ per minute. calculation formula : $(f_{max}-f_{min})/f_0$.
	Initial Frequency Tolerance	-0.2		+0.2	$\times 10^{-6}$	Measurement referenced to frequency observed with $T_A=25^{\circ}C$, $V_{cc}=3.3V$, $V_c=1.65V$, and after 15 minutes of operation, within 30 days after ex-works. Note: Secondary reflow absolutely not exceeded initial offset
	Frequency Tolerance vs. Supply Voltage	-1		+1	$\times 10^{-9}$	measurement referenced to frequency observed $T_A=25^{\circ}C$, V_{cc} varied from 3.13V to 3.47V, $V_c=1.65V$ and $O_{Load}=15pF$.
	Frequency Tolerance vs. Load	-1		+1	$\times 10^{-9}$	10% load change measurement referenced to frequency observed with $T_A=25^{\circ}C$, $V_{cc}=3.3V$, $V_c=1.65V$, and $O_{Load}=15pF$.



	Micro jump	-0.2		+0.2	$\times 10^{-9}$	power on 5days,Continuous testing for 48 hours, temperature fluctuations $< 3^{\circ}\text{C}$,one sampling/1H	
	Temper hysteresis effect	-0.5		+0.5	$\times 10^{-9}$	Over temperature range($0.5^{\circ}\text{C}/\text{minute}$) Note: batch sampling tests	
	Retrace	-0.01		+0.01	$\times 10^{-6}$	After 24 hours off @ 25°C 15 min power on	
	Reflow shift	-0.2		+0.2	$\times 10^{-6}$	After 24 hours recovery @ 25°C 2 times reflow.	
	Short-Term Stability Allan Variance				0.01	$\times 10^{-9}$	Temperature stability, no EMI\EMC or other interference, test after power for 1hour ref. to 25°C ; 1s.
					0.05	$\times 10^{-9}$	Temperature stability, no EMI\EMC or other interference, test after power for 1hour ref. to 25°C ; 100s.
	Aging Tolerance Per Day	-0.5		+0.5	$\times 10^{-9}$	V_{cc} , V_c , T_A constant measurement referenced to frequency observed with $T_A=25^{\circ}\text{C}$, $V_{cc}=3.3\text{V}$, $V_c=1.65\text{V}$, and after 30 days of operation.	
	Aging Tolerance 1 Year	-0.05		+0.05	$\times 10^{-6}$		
	Aging Tolerance 10 Year	-0.3		+0.3	$\times 10^{-6}$		
Aging Tolerance 15 Year	-0.4		+0.4	$\times 10^{-6}$			
Power Supply	Supply Voltage	3.13	3.3	3.47	V		
	Steady Consumption			400	mA	@ 25°C	
	Warm up current			900	mA		
	Warm-Up Time			8	minutes	@ 25°C within $\pm 0.01 \times 10^{-6}$ of final Frequency with reference after 1 hour on.	
Voltage Control Characteristics	Frequency Tuning Range	-2.4		-0.8	$\times 10^{-6}$	$V_c=0\text{V}$. measurement referenced to $V_c=1.65\text{V}$	
		-0.2		+0.2	$\times 10^{-6}$	$V_c=1.65\text{V}$. measurement referenced to exactly 10.00MHz	
		+0.8		+2.4	$\times 10^{-6}$	$V_c=3.3\text{V}$. measurement referenced to $V_c=1.65\text{V}$	
	Linearity			10	%		
	Slope	Positive					
	Input Impedance	100			K Ω		
	Modulation Bandwidth	100			Hz		



Phase Noise	Phase Noise @25°C		-85	-75	dBc/Hz	1Hz
			-120	-110		10Hz
			-140	-135		100Hz
			-145	-140		1KHz
			-150	-145		10KHz
			-150	-145		100KHz
			-155	-150		1MHz
Jitter				1	ps	RMS Jitter (12KHz-5MHz)
Environmental Conditions	Operable Temperature	-40		+90	°C	
	Storage Temperature	-40		+90	°C	
	Operable Environmental Conditions	5		85	%RH	
	ESD Level	Human Body Model, class2: 2000V to 4000V; ANSI/ESDA/JEDEC JS-001-2010.				
		Machine Model, class B: 200V to 400V; JEDEC JESD22-A115C.				
	Moisture Sensitivity Level	Level 3.				
	Vibration	Test Condition: 0.75mm ;acceleration:10g;5Hz~500Hz, one cycle per 30 min, test 2 hour. (3 times for each 3 directions X , Y , Z), IEC 68-2-06 Test Fc.				
Shock	50g; 11ms; half sine wave (3 times for each 3 directions X, Y, Z), IEC 68-2-27 Test Ea/Severity 50A.					
Free fall	100 mm, The frequency difference between before and after the test is less than 2E-7					
Full Package Storage	Relative humidity (%)	20%~70%				
	Temperature (°C)	-10~35°C				



2. Mechanical Structure (mm)

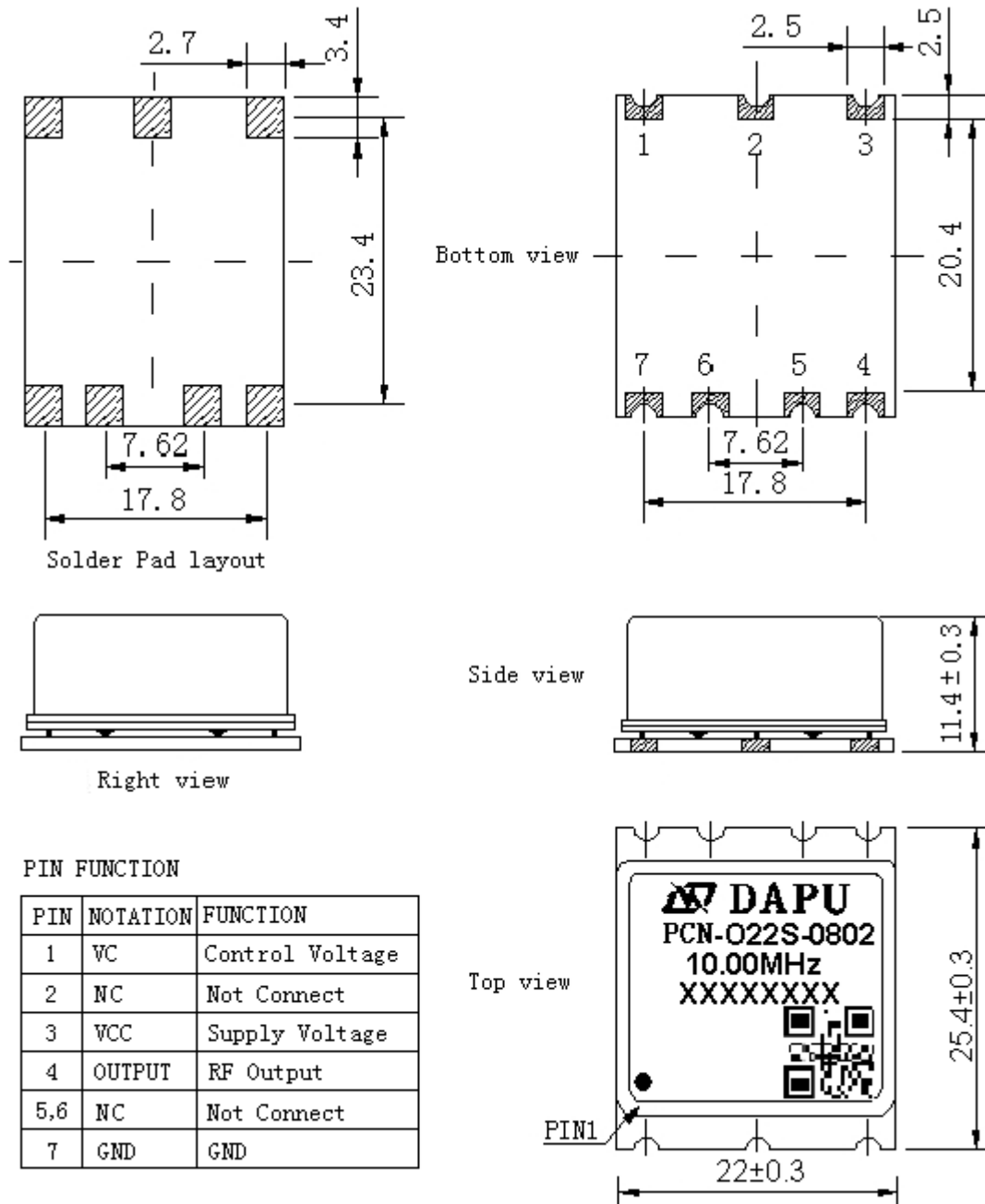

Note1: Tolerance $\pm 0.20\text{mm}$ without mark

Note2: The first two xx representative: year.

After two xx representative: week.

At last four xxxx representative: serial number.

Two dimensional code marking rules:

Material code + space + brand + space + batch (year week) + space + serial number.

The customer's material code is 030062000042

Take 62 in the middle and the last three digits as the material code number in the two dimensional code.

Note3: Referential weight 7.8g



3. Current vs. Temperature

Airflow=1.5m/s

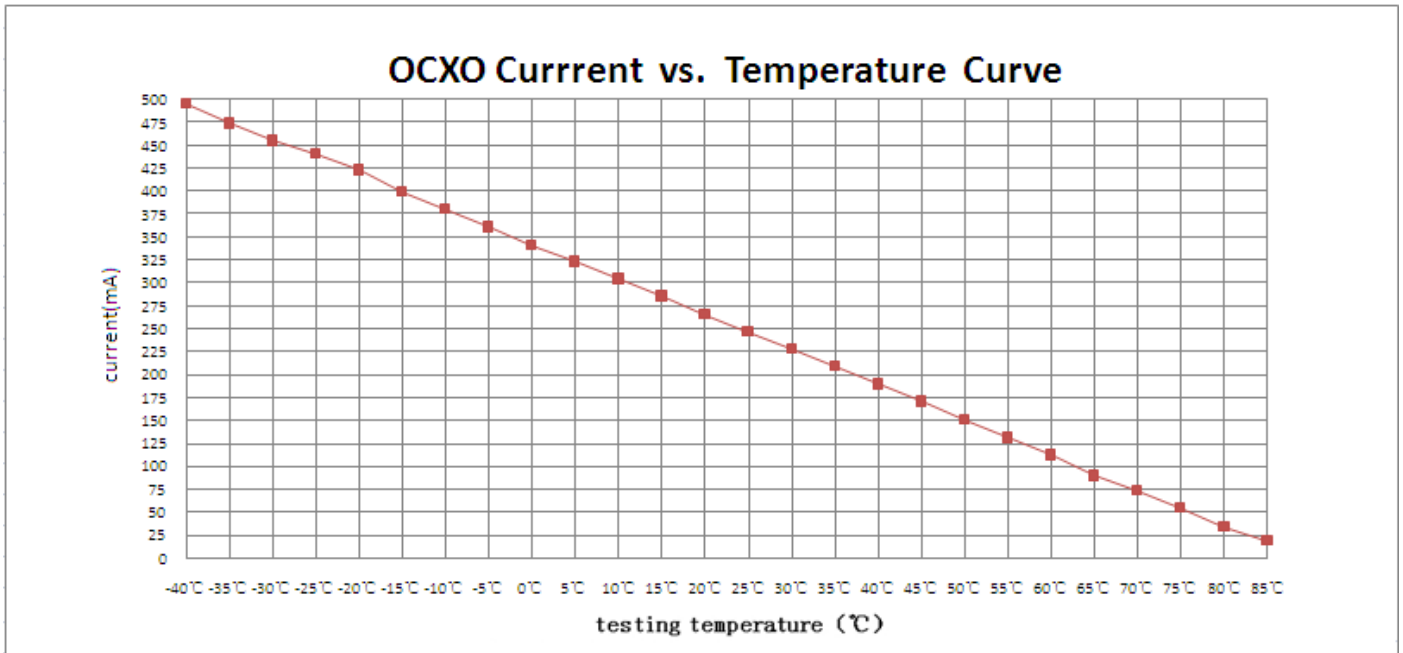

Airflow=0m/s

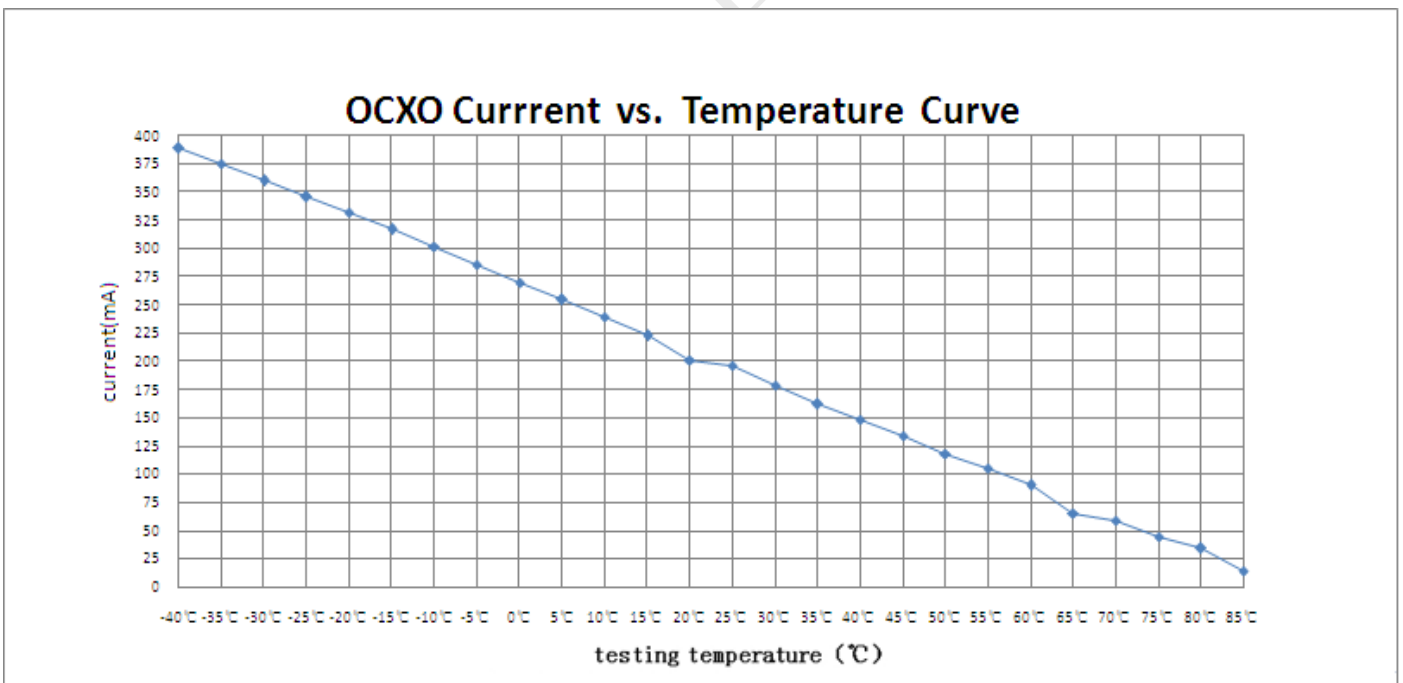



4. Test Circuit

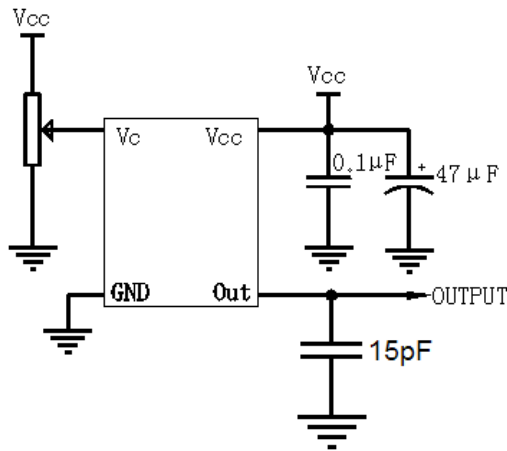

5. Reflow Soldering Curve (RoHS)

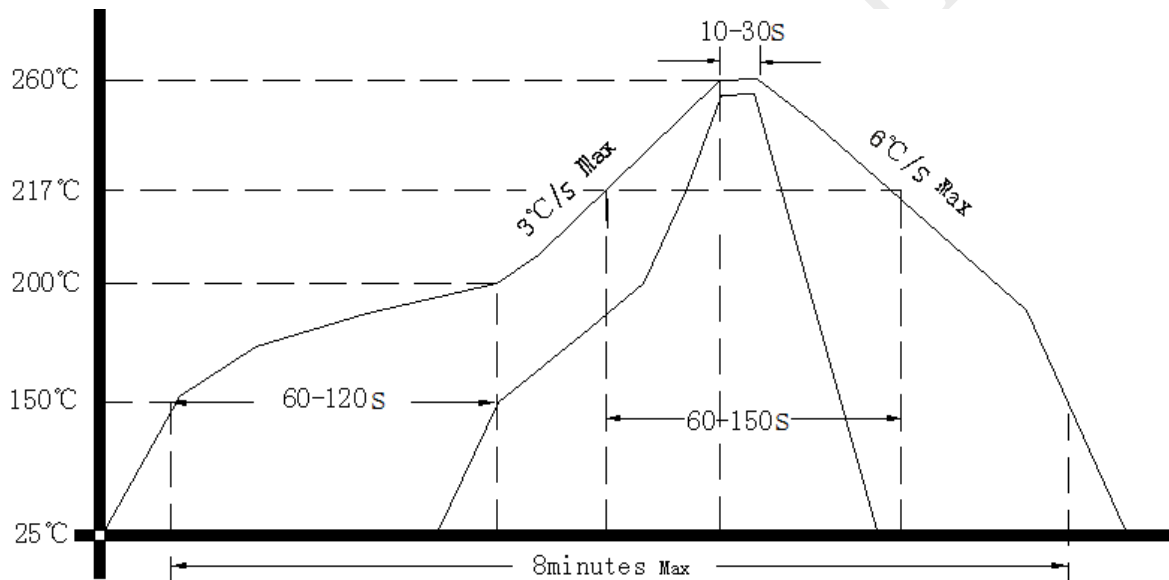

6. Package: Tape & Reel (mm)

