



Table of amendment

Version	Revision contents	Prepared by	Revised date
1.0	The first issued	<i>Amway</i>	2020.02.13
1.1	The “ESD Level” “Moisture Sensitivity Level” “I2C Devices Address” “ Package: Tape & Reel” changed	<i>Amway</i>	2020.07.08
1.2	The “Mechanical Structure” changed	<i>Amway</i>	2021.03.05
1.3	The “Output High Voltage” changed	<i>Amway</i>	2021.04.19
1.4	The “Mechanical Structure” changed	<i>Amway</i>	2021.04.27
1.5	The “Package: Tape & Reel” changed	<i>Amway</i>	2021.08.04
1.6	The “Package: Tape & Reel” changed	<i>Amway</i>	2021.09.23



1. Electrical Parameters

MODEL: O22S-3704-10.00MHz						
Item	Description	Parameters			Unit	Test Condition
		Min.	Typ.	Max.		
Output	Frequency	10.00			MHz	
	Output Waveform	LVCMOS				
	Output Low Voltage			0.4	V	$V_{cc}=3.3V$, Load =15pF
	Output High Voltage	2.6			V	$V_{cc}=3.3V$, Load =15pF
	Duty Cycle	45	50	55	%	
	Spurious Suppression			-90	dBc	
	Rise/Fall Time			8	ns	
	Load	15			pF	
Frequency Stabilities	Initial Frequency Tolerance	-1.0		+1.0	$\times 10^{-6}$	After 2 hours and 5 minutes warm up time (after reflow), Measurement referenced to the frequency (before reflow)
	Frequency Stability vs. Operating Temperature Range	-5.0		+5.0	$\times 10^{-9}$	T_A varied from -40 to $90^\circ C$, $V_{cc}=3.3V$, and Load = 15pF.Measurement referenced to frequency observed With $T_A = 25^\circ C$, $V_{cc}=3.3V$.
	Frequency Tolerance after Temperature Compensated vs Operating Temperature Range(at 3rd and 5th Polynomial)	-0.3		+0.3	$\times 10^{-9}$	T_A varied from -40 to $90^\circ C$, $V_{cc}=3.3V$, and Load = 15 pF. Measurement referenced to frequency observed With $T_A = 25^\circ C$, $V_{cc}=3.3V$.
	Frequency Jump			0.05	$\times 10^{-9}$	Continuous testing for 48 hours, temperature Fluctuations $< 3^\circ C$, one sampling/10s.
	Hysteresis			0.3	$\times 10^{-9}$	
	Frequency Stability vs. Supply Voltage	-0.5		+0.5	$\times 10^{-9}$	measurement referenced to frequency observed $T_A=25^\circ C$, V_{cc} varied from 3.13V to 3.47V, and $O_{Load}=15pF$.
	Frequency Tolerance vs Load	-0.5		+0.5	$\times 10^{-9}$	5% load change measurement referenced to frequency observed with $T_A=25^\circ C$, $V_{cc}=3.3V$, and $O_{Load}=15pF$.



	Aging Tolerance day	-0.6		+0.6	$\times 10^{-9}$	After 3 days
	Aging Slope Variation (/day)	-0.4		+0.4	$\times 10^{-9}$	
	Aging Tolerance 10 Years	-0.5		+0.5	$\times 10^{-6}$	
Power Supply	Supply Voltage	3.13	3.3	3.47	V	
	Steady Consumption			400	mA	@25°C
	Warm up current			1000	mA	
	Warm-Up Time			5	minutes	@25 °C within $\pm 0.02 \times 10^{-6}$ of final frequency with reference after 1 hours on.
			10	minutes	@25 °C within $\pm 0.01 \times 10^{-6}$ of final frequency with reference after 1 hours on.	
Phase Noise	Phase Noise			-80	dBc/Hz	1Hz
				-120		10Hz
				-140		100Hz
				-145		1KHz
				-150		10KHz
				-150		100KHz
Environmental Conditions	Operating Temperature	-40		+90	°C	
	Storage Temperature	-55		+125	°C	
	ESD Level	Human Body Model, class2: 2000V to 4000V; ANSI/ESDA/JEDEC JS-001-2010.				
		Machine Model, class B: 200V to 400V; JEDEC JESD22-A115C.				
	Moisture Sensitivity Level	Level 2.				
	Vibration	Test Condition: 0.75mm ;acceleration:10g;10Hz~500Hz, one cycle per 30 min, test 2 hour. (3 times for each 3 directions X ,Y , Z), IEC 68-2-06 Test Fc.				
Shock	50g; 11ms; half sine wave (3 times for each 3 directions X ,Y , Z),IEC 68-2-27 Test Ea/Severity 50A.					
Full Package Storage	Relative Humidity (%)	20% ~70%				
	Temperature (°C)	-10~35°C				



2. Mechanical Structure (mm)

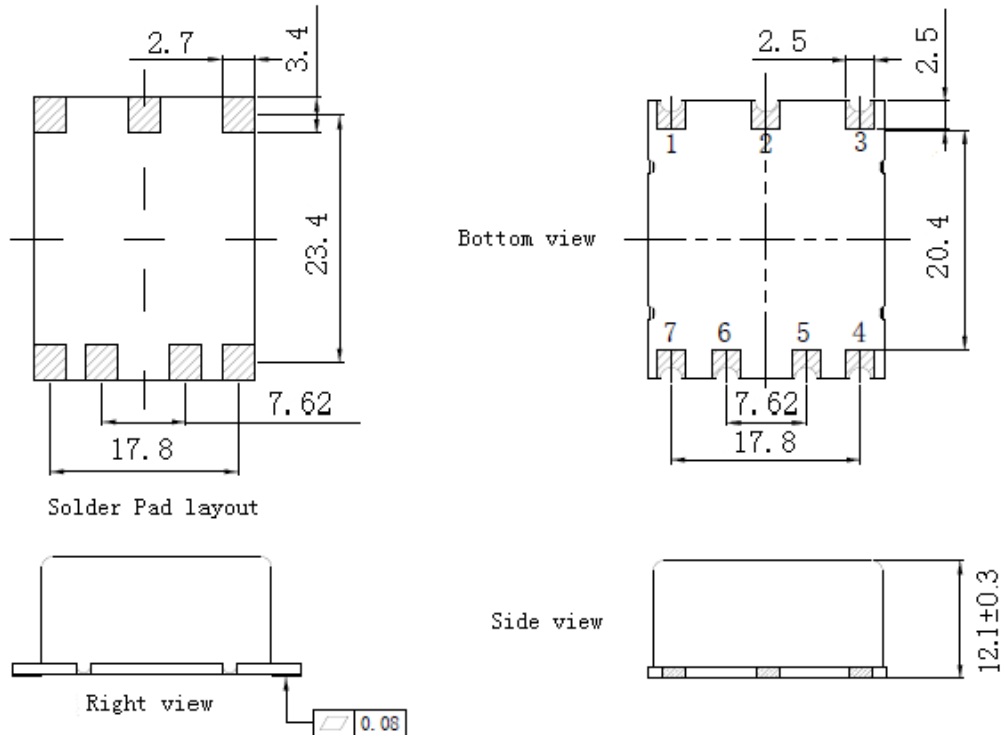

PIN FUNCTION

PIN	FUNCTION
1	NC
2	Reset
3	Supply Voltage
4	RF Output
5	SCL
6	SDA
7	GND

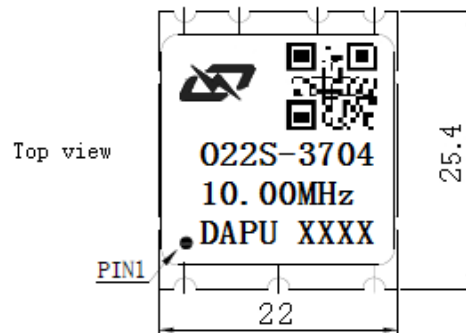

Note1: Tolerance ± 0.20mm without mark.

Note2: The first two xx representative: year.

After two xx representative: week.

Note3: Referential weight 10g.

Note4: NC is not connect.

Note5: Pin2 function: When the Reset Voltage is lower than 0.2V_{cc} and the state keeps longer than 1ms, chip will be Reset. The Reset will control the chip in reset state until the Reset Voltage rises above 0.8V_{cc} and the state keeps longer than 1ms. I2C access will be available after 50ms following reset release.

Note6: The altitude difference of 7 pad was less than 0.08mm and 7 pads must be higher than other PCB areas.



3. I²C Devices Address

Device name: PIC16F1704

Device supplier: MICROCHIP

Device address: 1110 000

Memory map

Address	Size bytes	Parameter	Format	Value
0000h~0004h	5	Vendor ID	ASCII	DP
0005h~0024h	32	Vendor Product ID	ASCII	022S-3704-10.00MHz
0025h~0028h	4	Nominal frequency in Hertz	32-bit unsigned integer	10000000
0029h~002Ch	4	Device serial number	32-bit unsigned integer	001
002Dh~0032h	6	Date code of manufacture	ASCII	“YYMMDD”
0033h~003dh	11	PxxxxxxYYWW P:Vedor code, xxxxxx: OCXO serial number(Insert a null marker at the end when a digit is left.) YY : Production Year, ex)19 => 2019 WW : Production Week, ex) 45, 45weeks	ASCII	“PxxxxxxYYWW”
003Eh~003Fh	2	SAMSUNG Reserved		00h
0040h~006Fh	48	Vendor Reserved		
0070h~0077h	8	B ₀	64-bit floating point	-1.02E+02
0078h~007Fh	8	B ₁	64-bit floating point	7.40E-01
0080h~0087h	8	C ₀	64-bit floating point	7.40E-01
0088h~008Fh	8	C ₁	64-bit floating point	-5.23E-03
0090h~0097h	8	C ₂	64-bit floating point	3.77E-05
0098h~009Fh	8	C ₃	64-bit floating point	-9.08E-07
00A0h~00A1h	2	PMIN	16-bit unsigned integer	330
00A2h~00A3h	2	PMAX	16-bit unsigned integer	970
00A4h~00C3h	32	SAMSUNG Reserved		00h
00C4h~00EFh	44	Vendor Reserved		



00F0h~00F1h	2	OCXO Temperature 10-bit ADC Value	16-bit unsigned integer	528
00F2h~00FFh	14	Vendor Reserved		

Note1: All numerical values are stored in little endian format

Note 2: SDA, SCL Input low voltage is 0.3V_{cc} Max, Input high voltage is 0.7V_{cc} Min.

Note 3: MCU and I2C reset do not affect the output quality and waveform of crystal oscillator signal.

Note4: I2C Clock Speed: 100kbit/s Max.

Note5: Pmin: V_{temp_Min} ADC value, the possible minimum Low Temperature

Pmax: V_{temp_Max} ADC value, the possible maximum High Temperature.

ADC bit map:

BIT	0	1	2	3	4	5	6	7	8	9	10	11	12	13	14	15
10 bit ADC	0x000 - 0x3FF										0	0	0	0	0	0

4. Temperature measurement and compensation scheme

Temperature compensation formula(three functions):

$$C_3P^3 + C_2P^2 + C_1P + C_0 = \frac{f(P) - f(P_{ref})}{f(P_{ref})}$$

C_x: Temperature compensation parameters (see register list)

P: This parameter is read by ADC and is related to temperature.

f(P): measured frequency.

P_{ref}: Parameter variables associated with the reference Temperature (25°C)

OCXO Ambient temperature calculation formula:

$$B_1P + B_0 = Ta[°C]$$



5. Test Circuit

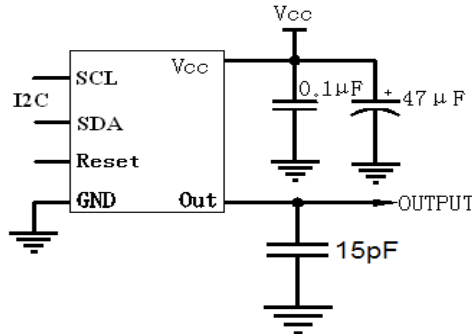

6. Reflow Soldering Curve (RoHS)

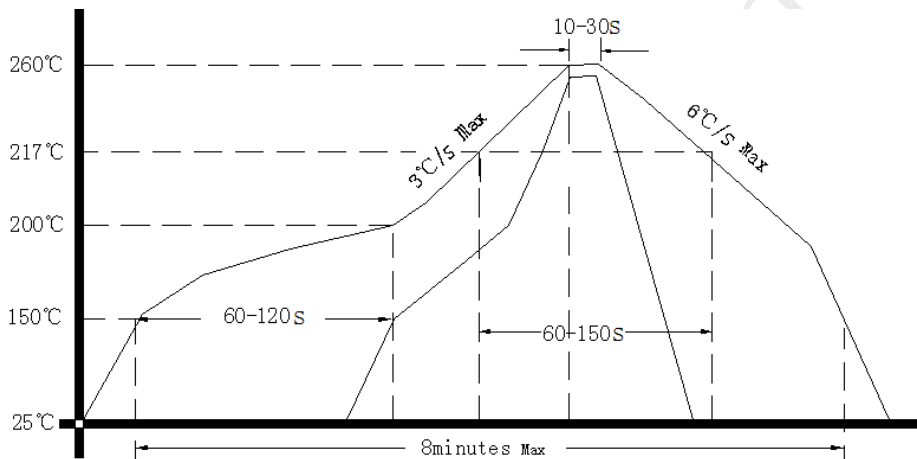

Note: passing through reflow upside down is not supported

7. Package: Tape & Reel (mm)

