

Travelling Merchant: _____

DATASHEET

Standard: T2925-R426-156.25MHz

P/N: _____

Plot			The Label
Drew	Audited	Approved	Stamp, please! Thanks!
Date : 2022.04.21			

Guangdong Dapu Telecom Technology Co.,Ltd

Building 5, No.24, Industrial East Road, Songshanhu Park, Dongguan, Guangdong, P.R. China

TEL : 0086-0769-88010888 FAX : 0086-0769-81800098



1. Electrical Parameters

MODEL : T2925-R426-156.25MHz						
Item	Description	Parameters			Unit	Test Condition
		Min.	Typ.	Max.		
Output	Frequency	156.25			MHz	
	Output Waveform	Sine Wave				
	Level	0	3	6	dBm	
	Harmonics			-30	dBc	
	Sub-Harmonics			-30	dBc	
	Load	50			Ω	
Frequency Stabilities	Frequency Tolerance vs. Operating Temperature Range	-3		+3	$\times 10^{-6}$	T_A varied from 0°C to 70°C , measurement referenced to frequency observed with $T_A = 25^{\circ}\text{C}$, $V_{cc}=5.0\text{V}$, $V_c=2.5\text{V}$, $O_{load}=50\Omega$, temperature variable speed less than 2°C per minute.
	Initial Frequency Tolerance	-1.0		+1.0	$\times 10^{-6}$	Measurement referenced to frequency observed with $T_A = 25^{\circ}\text{C}$, $V_{cc}=5.0\text{V}$, $V_c = 2.5\text{V}$ within 30 days after ex-works.
	Frequency Tolerance vs. Supply Voltage	-0.2		+0.2	$\times 10^{-6}$	measurement referenced to frequency observed $T_A=25^{\circ}\text{C}$, V_{cc} varied from 4.75V to 5.25V, $V_c = 2.5\text{V}$ and $O_{Load}=50\Omega$.
	Frequency Tolerance vs. Load	-0.2		+0.2	$\times 10^{-6}$	5% load change measurement referenced to frequency observed with $T_A= 25^{\circ}\text{C}$, $V_{cc}=5.0\text{V}$, $V_c=2.5\text{V}$, $O_{Load}=50\Omega$.
	Aging Tolerance 1st Year	-1.5		+1.5	$\times 10^{-6}$	$T_A=25^{\circ}\text{C}$, $V_{cc}=5.0\text{V}$, $V_c=2.5\text{V}$ and after 1h of operation.
	Aging Tolerance Year (after year 1)	-1.0		+1.0	$\times 10^{-6}$	
	Aging Tolerance 15 Years	-7.0		+7.0	$\times 10^{-6}$	
Power Supply	Current Consumption		30	40	mA	@ 25°C
	Supply Voltage	4.75	5.0	5.25	V	



Voltage Control Characteristics	Frequency Tuning Range	-50		-15	$\times 10^{-6}$	$V_c=0V$. measurement referenced to $V_c=2.5V$
		-1.0		+1.0	$\times 10^{-6}$	$V_c=2.5V$. measurement referenced to exactly 156.25MHz
		+15		+50	$\times 10^{-6}$	$V_c=5V$. measurement referenced to $V_c=2.5V$
	Linearity			20	%	
	Slope	Positive				
Phase Noise	Phase Noise			-59	dBc/Hz	10Hz
				-94		100Hz
				-119		1KHz
				-145		10KHz
				-155		100KHz
				-155		1MHz
				-155		10MHz
				-155		20MHz
Environmental Conditions	Operable Temperature	-40		+85	$^{\circ}C$	
	Storage Temperature	-55		+105	$^{\circ}C$	
	ESD Level	Human Body Model,class2: 2000V to 4000V; ANSI/ESDA/JEDEC JS-001-2010.				
		Machine Model, class B: 200V to 400V; JEDEC JESD22-A115C.				
	Moisture Sensitivity Level	Level: 2				
	Vibration	Test Condition: 0.75mm ;acceleration:10g;10Hz ~ 2000Hz, one cycle per 30 min, test 2 hour. (3 times for each 3 directions X ,Y , Z) .IEC 68-2-06 Test Fc.				
	Shock	100g ; 6ms ; half sine wave (3 times for each 3 directions X ,Y , Z),IEC 68-2-27 Test Ea/Severity 50A.				
RoHS Compliance	This part is fully RoHS compliant					
Full Package Storage	Relative humidity (%)	20% ~ 70%				
	Temperature ($^{\circ}C$)	-10~35 $^{\circ}C$				



2. Mechanical Structure(mm)

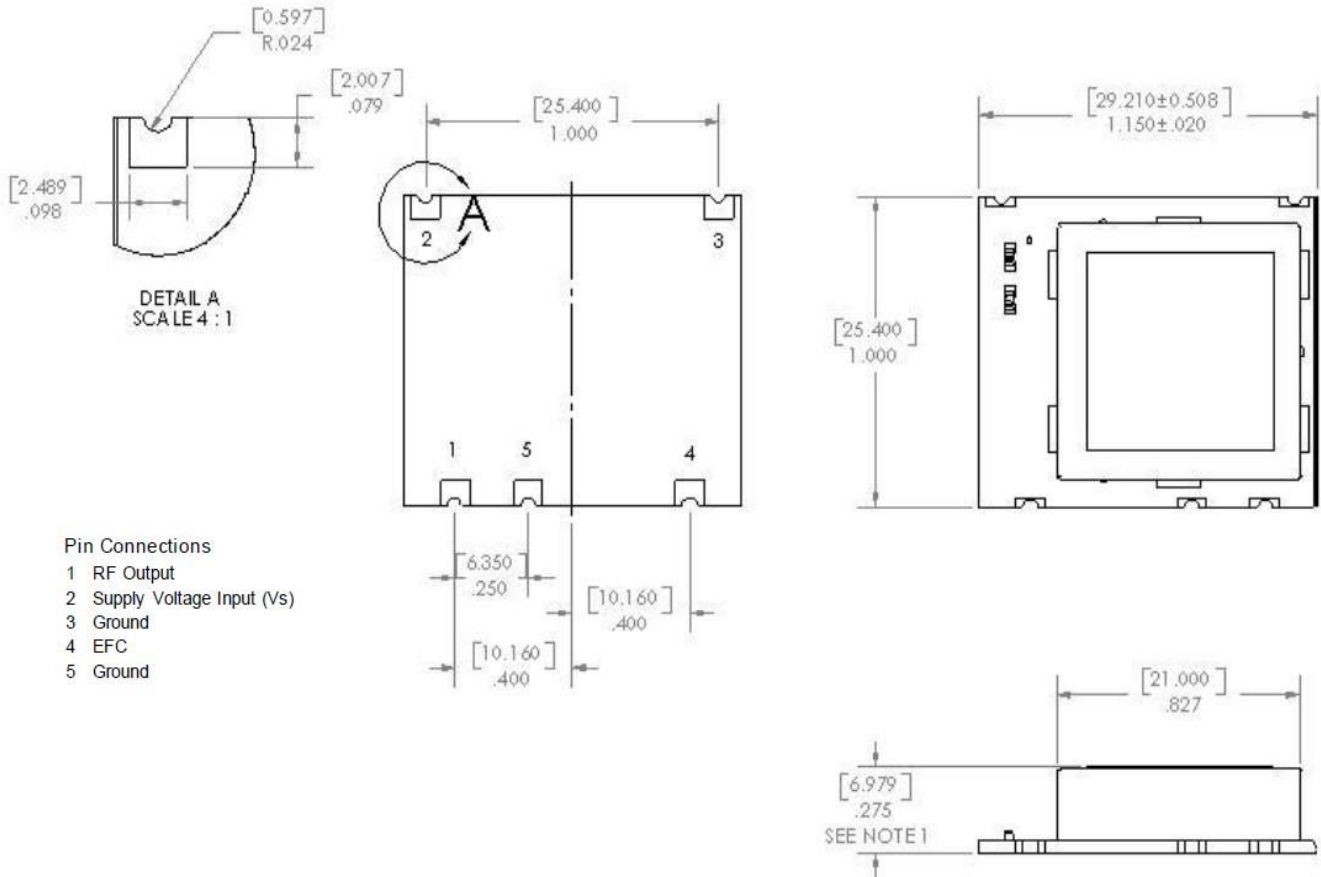

Note1: Tolerance $\pm 0.2\text{mm}$ without mark

Note2: Referential weight 8g

3. Reflow Soldering Curve (RoHS)

