

Customer Code: \_\_\_\_\_

# DATASHEET

DAPU P/N: 022S-F445-10.00MHz

Customer P/N: \_\_\_\_\_

DAPU			Customer Approval
Drew	Audited	Approved	Stamp, please! Thanks!
Date: 2021.08.04			

## Guangdong Dapu Telecom Technology Co.,Ltd

Building 5, No.24, Industrial East Road, Songshanhu Park, Dongguan, Guangdong, P.R. China

TEL: 0086-0769-88010888 FAX: 0086-0769-81800098





## 1. Electrical Parameters

MODEL: O22S-F445-10.00MHz						
Item	Description	Parameters			Unit	Test Condition
		Min.	Typ.	Max.		
Output	Frequency	10.00			MHz	
	Output Waveform	Sine wave				
	Level	5		10	dBm	
	Load	50			$\Omega$	
	Harmonics Suppression			-20	dBc	At frequency range 9-11MHz
	Spurious Suppression			-90	dBc	Except 9-11MHz
Reference Voltage Output	Reference Voltage	4.925	5	5.075	V	
	Internal Resistance			100	$\Omega$	
Alarm Output	Alarm Level	0		0.4	V	
	Ready Level	2.4		3.6	V	
	Load Current			100	$\mu$ A	
Frequency Stabilities	Frequency Tolerance vs. Operating Temperature Range	-5		+5	$\times 10^{-9}$	$T_A$ varied from $-20^{\circ}\text{C}$ to $75^{\circ}\text{C}$ , measurement referenced to frequency observed with $f_{ref}=(f_{max}+f_{min})/2$ , $V_{cc}=10.5\text{V}\sim 12.6\text{V}$ , $O_{load}=50\Omega$ , temperature variable speed less than $2^{\circ}\text{C}$ per minute.
	Initial Frequency Tolerance	-0.1		+0.1	$\times 10^{-6}$	Measurement referenced to frequency observed with $T_A=25^{\circ}\text{C}$ , $V_{cc}=10.5\text{V}\sim 12.6\text{V}$ , $V_c=2.5\text{V}$ , and after 15 minutes of operation, within 30 days after ex-works.
	Frequency Tolerance vs. supply voltage	-0.5		+0.5	$\times 10^{-9}$	measurement referenced to frequency observed $T_A=25^{\circ}\text{C}$ , $V_{cc}=10.5\text{V}\sim 12.6\text{V}$ , $V_c=2.5\text{V}$ , $O_{load}=50\Omega$ .
	Frequency Tolerance vs. Load	-0.5		+0.5	$\times 10^{-9}$	5% Load Change Measurement referenced to frequency observed with $T_A=25^{\circ}\text{C}$ , $V_{cc}=10.5\text{V}\sim 12.6\text{V}$ , $V_c=2.5\text{V}$ , $O_{load}=50\Omega$ .
	Orientation	-6		+6	$\times 10^{-9}$	
	Short-Term Stability: Allan Variance			0.005	$\times 10^{-9}$	Temperature stability, no EMI\EMC or other interference, test after power for 1hour ref. to $25^{\circ}\text{C}$ ; 1s.
			0.01	$\times 10^{-9}$	Temperature stability, no EMI\EMC or other interference, test after power for 1hour ref. to $25^{\circ}\text{C}$ ; 10s.	
			0.1	$\times 10^{-9}$	Temperature stability, no EMI\EMC or other interference, test after power for 1hour ref. to $25^{\circ}\text{C}$ ; 100s.	



	Aging Tolerance Per Day	-0.5		+0.5	$\times 10^{-9}$	$V_{cc}, V_c, T_A$ constant Measurement referenced to frequency observed with $T_A=25^\circ\text{C}$ , $V_{cc}=10.5\text{V}\sim 12.6\text{V}$ , $V_c=2.5\text{V}$ , $O_{load}=50\Omega$ and after 30 days of operation.	
	Aging Tolerance Per 30 Day	-5		+5	$\times 10^{-9}$		
	Aging Tolerance Per Year	-0.03		+0.03	$\times 10^{-6}$		
	Aging Tolerance 15 Year	-0.5		+0.5	$\times 10^{-6}$		
	Retrace			5	$\times 10^{-9}$		@25°C after 24hours power on/2 hours off/1 hour power on.
Power Supply	Supply Voltage	10.5	12.0	12.6	V		
	Steady Consumption			400	mA	@-20°C	
					340	mA	@25°C
					380	mA	@0°C
Warm up current			400	mA			
Warm-Up Time			10	min			
Voltage Control Characteristics	Frequency Tuning Range	-1.5		-0.8	$\times 10^{-6}$	$V_c=0\text{V}$ . measurement referenced to $V_c=2.5\text{V}$	
		-0.1		+0.1	$\times 10^{-6}$	$V_c=2.5\text{V}$ . measurement referenced to exactly 10.00MHz	
		+0.8		+1.5	$\times 10^{-6}$	$V_c=5.0\text{V}$ . measurement referenced to $V_c=2.5\text{V}$	
	Tuning Sensitivity	$\pm 0.32$		$\pm 0.6$	ppm/V	$V_c=0\text{V}\sim 5\text{V}$	
	Linearity			10	%		
	Slope	Positive					
	Input Impedance	100			K $\Omega$		
Phase Noise	Phase Noise @25°C		-70		dBc/Hz	0.1Hz	
				-100		1Hz	
				-130		10Hz	
				-145		100Hz	
				-150		1KHz	
				-150		10KHz	
				-150		100KHz	
Environmental Conditions	Operating Temperature	-20		+75	°C		
	Operable Temperature	-30		+80	°C		
	Storage Temperature	-55		+105	°C		
	ESD Level	Human Body Model, class2: 2000V to 4000V; ANSI/ESDA/JEDEC JS-001-2010. Machine Model, class B: 200V to 400V; JEDEC JESD22-A115C.					



	Moisture Sensitivity Level	Level 2.
	Vibration	Test Condition: 0.75mm ;acceleration:10g;10Hz~500Hz, one cycle per 30 min, test 2 hour. (3 times for each 3 directions X ,Y , Z), IEC 68-2-06 Test Fc.
	Shock	50g; 11ms; half sine wave (3 times for each 3 directions X ,Y, Z ),IEC 68-2-27 Test Ea/Severity 50A.
Air pressure	Operating	54kPa(equiv.5000m)
	Non operating	26kPa(equiv.10000m)
MTBF	@100% operating time and 45°C ambient temperature [hours] >100 000	
Full Package Storage	Relative humidity (%)	20%~70%
	Temperature (°C)	-10~35°C



## 2. Mechanical Structure (mm)

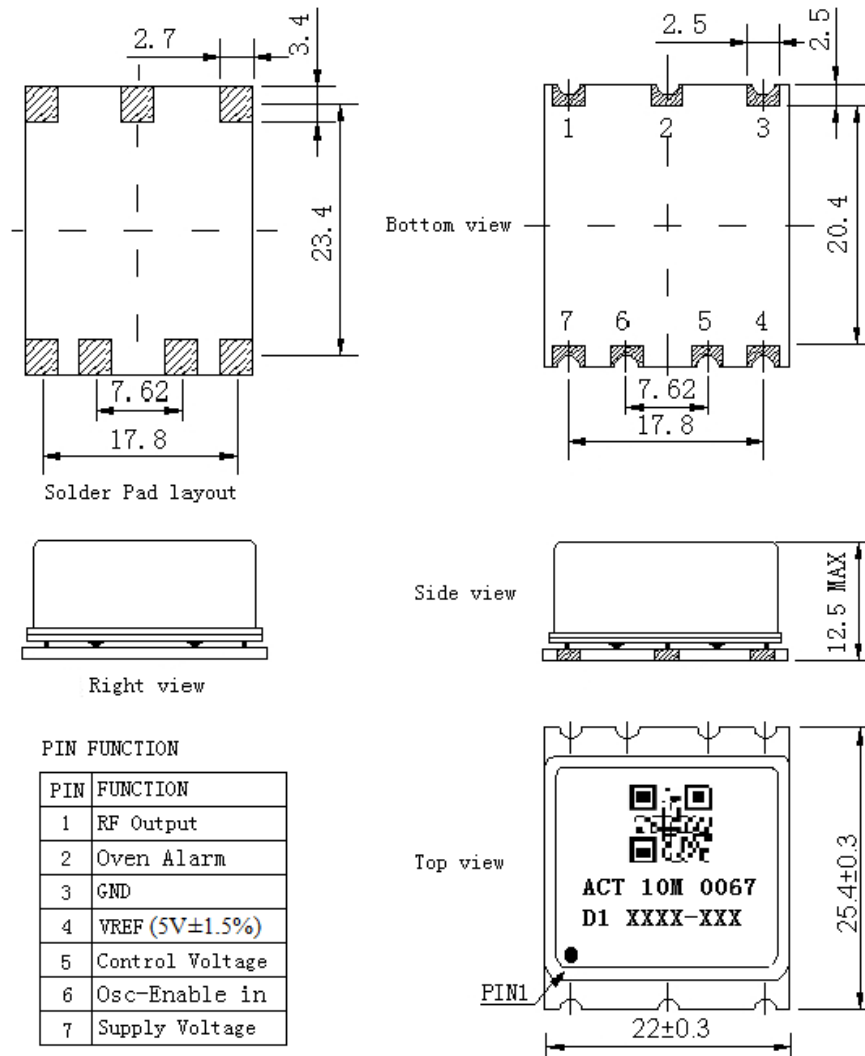

**Note1:** Tolerance  $\pm 0.20\text{mm}$  without mark.

**Note2:** The first two xx representative: week  
After two xx representative: year  
At last three xxx representative: serial number

**Note3:** Referential Weight 10g.

**Note4:** Instruction of Pin 6:

- 1): Oscillator must be switched ON with high signal: TTL/CMOS/HCMOS compatible input.
- 2): High level up to 12.6V, high level min 2.4V, must be acceptable. The input impedance  $\geq 100\text{ K}\Omega$ .
- 3): When the voltage is between 2.4V and 12.6V, the RF output pin needs to output a signal between 5dBm and 10dBm.
- 4): When the voltage is 0 ~ 2.4V, the RF output pin cannot have signal output.
- 5): With OSC-enable = low (0 ~ 2.4V) the internal oscillator is not oscillating. It is totally switched off.
- 6): If Osc-Enable function is not used, Pin6 must be connected to Pin7.



### 3. Test Circuit

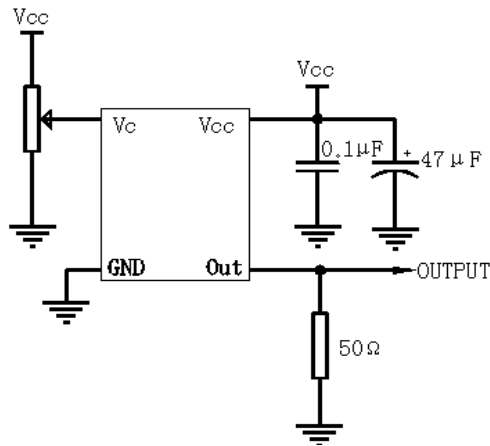

### 4. Reflow Soldering Curve (RoHS)

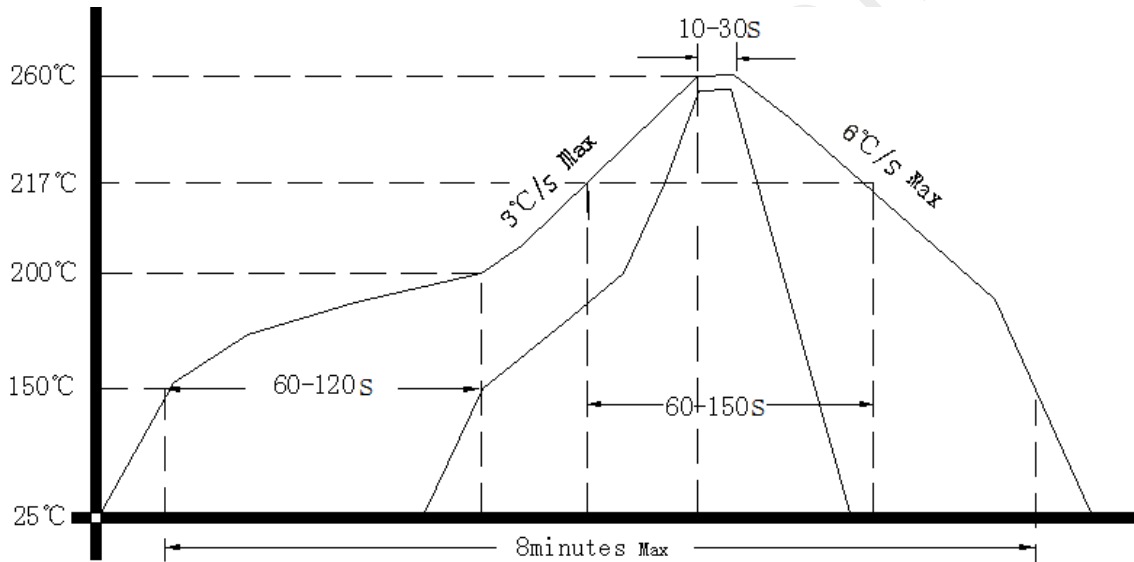

### 5. Package: Tape & Reel (mm)

