

Travelling Merchant: _____

DATASHEET

Standard: DP6P22120001

Plot			The Label
Drew	Audited	Approved	Stamp, please! Thanks!
Date:			

Guangdong Dapu Telecom Technology Co.,Ltd

Bldg13-16,.N.Ind.Zone,SSL Industry Park, Dongguan City, Guangdong Province, China

TEL: 0086-0769-88010888 FAX: 0086-0769-81800098



1、 Electrical Parameters

MODEL: DP6P22120001							
No.	Parameters	SYM.	Electrical Spec.				Notes
			Min.	Typ.	Max.	Units	
1	Nominal Frequency	FL	22.1184			MHz	
2	Oscillation Mode	-	Fundamental			-	
3	Load Capacitance	CL	20			pF	
4	Frequency Tolerance	-	-10	-	+10	$\times 10^{-6}$	at 25°C± 3°C
5	Frequency Stability	-	-20	-	+20	$\times 10^{-6}$	Over Operating Temp. Range (Reference 25°C)
6	Operating Temperature	-	-40	~	+85	°C	
7	Aging	-	-3	-	+3	$\times 10^{-6}$	1st Year
8	Drive Level	DL	-	0.10	1.00	mW	
9	Effective Resistance Rr	Rr	-	-	35	Ω	
10	Shunt Capacitance C0	C0	-	-	7.0	pF	
11	Insulation Resistance	-	500	-	-	M Ω	at DC 100V
12	Storage Temperature Range	-	-55	~	+125	°C	
13	ESD Level	Human Body Model,class2: 2000V to 4000V; ANSI/ESDA/JEDEC JS-001-2010					
		Machine Model, class B: 200V to 400V; ANSI/ESDA/JEDEC JS-001-2010					
14	Moisture Sensitivity Level	Level 2					
15	Vibration	Test Condition: 0.75mm ;acceleration:10g;10Hz~2000Hz, one cycle per 30 min, test 2 hour. (3 times for each 3 directions X ,Y , Z). IEC 68-2-06 Test Fc.					
16	Shock	100g; 6ms; half sine wave (3 times for each 3 directions X ,Y , Z),IEC 68-2-27 Test Ea/Severity 50A.					



2、Mechanical Structure(mm)

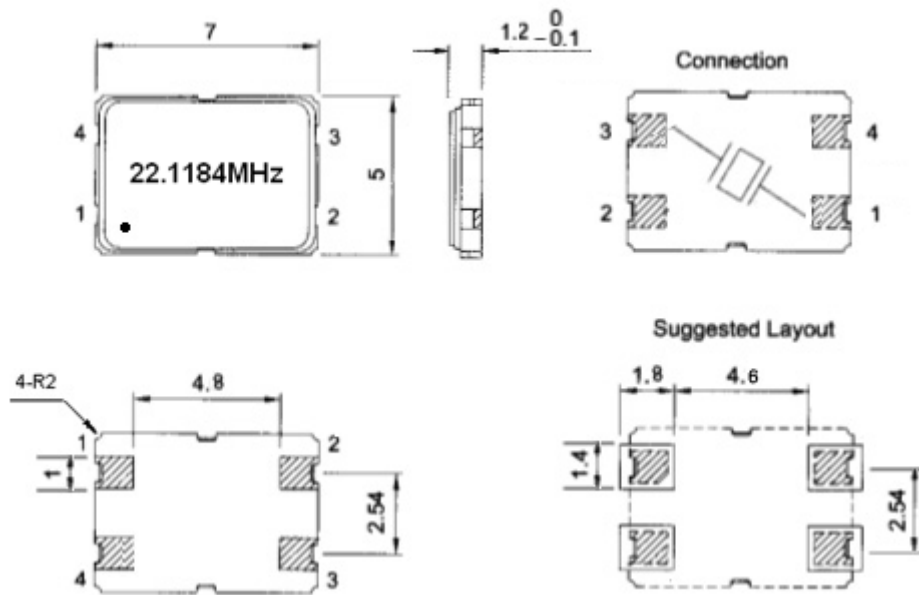

3、Reflow Soldering Curve (RoHS)

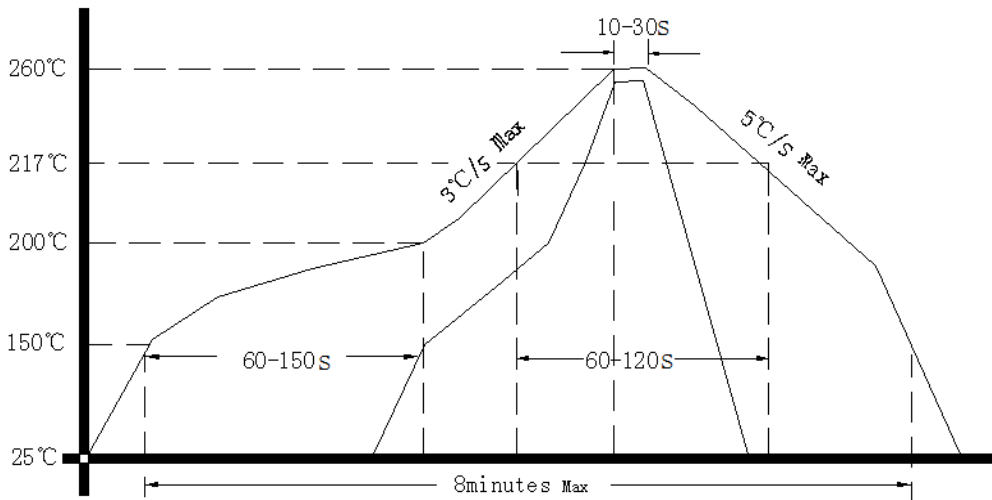

4、Package: Tape & Reel (mm)

