

Travelling Merchant: _____

DATASHEET

Standard: **DPAM48000002**

Plot			The Label
Drew	Audited	Approved	Stamp, please! Thanks!
Date: 2021.01.08			

Guangdong Dapu Telecom Technology Co.,Ltd

Bldg13-16,.N.Ind.Zone,SSL Industry Park, Dongguan City, Guangdong Province, China

TEL: 0086-0769-88010888 FAX: 0086-0769-81800098



1、 Electrical Parameters

MODEL: DPAM48000002							
No.	Parameters	SYM.	Electrical Spec.				Notes
			Min.	Typ.	Max.	Units	
1	Nominal Frequency	FL	48.00			MHz	Original frequency
2	Oscillation Mode	-	Fundamental			-	
3	Load Capacitance	CL	12			pF	
4	Frequency Tolerance	-	-10		+10	$\times 10^{-6}$	at 25°C $\pm 3^\circ\text{C}$
5	Frequency Stability	-	-30		+30	$\times 10^{-6}$	Refer to Operating temperature Range(Ref.to 25°C)
6	Operating Temperature	-	-40	~	+85	°C	
7	Storage Temperature Range	-	-40	~	+85	°C	
8	Aging	-	-3		+3	$\times 10^{-6}$	First Year
9	Drive Level	DL			100	uW	
10	Effective Resistance Rr	Rr	-	-	30	Ω	
11	Shunt Capacitance C0	C0			3	pF	
12	Insulation Resistance	-	500	-	-	M Ω	at DC 100V
13	ESD Level	Human Body Model,class2: 2000V to 4000V; ANSI/ESDA/JEDEC JS-001-2010					
		Machine Model, class B: 200V to 400V; JEDEC JESD22-A115C.					
14	Moisture Sensitivity Level	Level 2					
15	Vibration	Test Condition: 0.75mm ;acceleration:10g;10Hz~2000Hz, one cycle per 30 min, test 2 hour. (3 times for each 3 directions X , Y , Z). IEC 68-2-06 Test Fc.					
16	Shock	100g; 6ms; half sine wave (3 times for each 3 directions X , Y , Z),IEC 68-2-27 Test Ea/Severity 50A.					



2、 Mechanical Structure(mm)

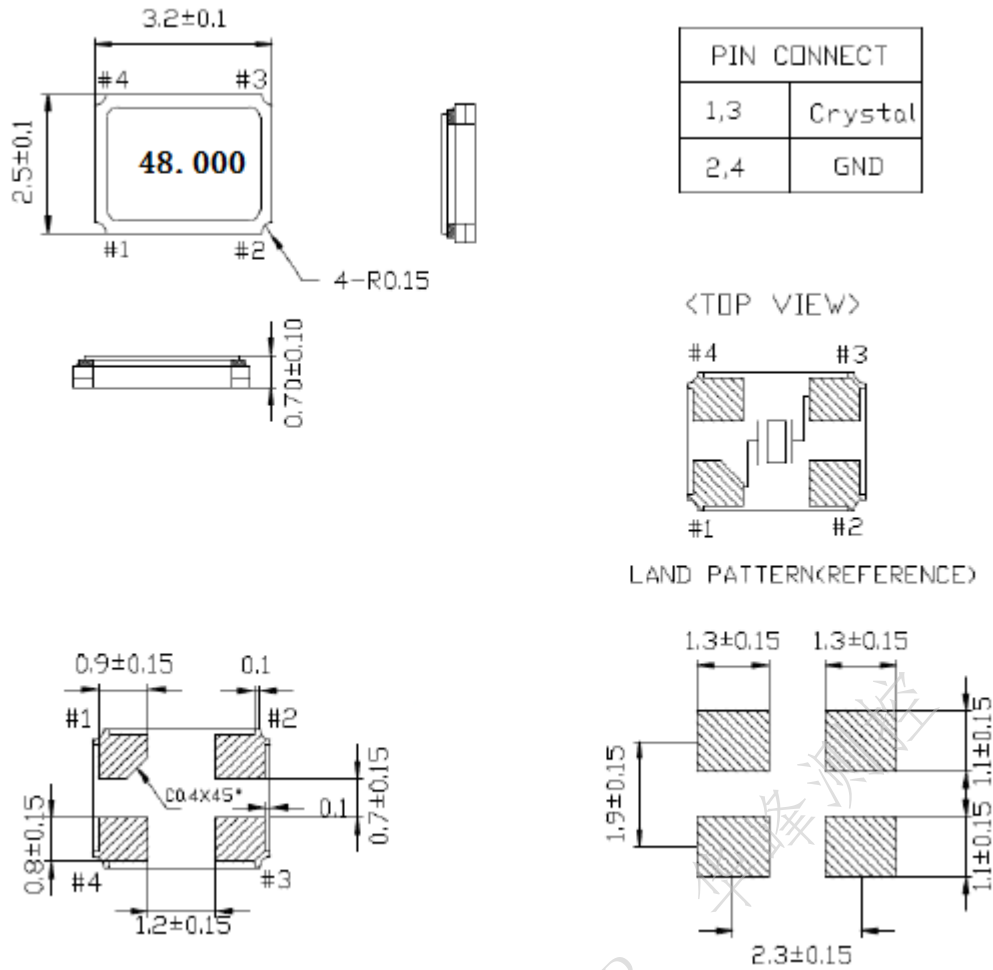

Note: Tolerance ±0.2mm

3、 Reflow Soldering Curve (RoHS)

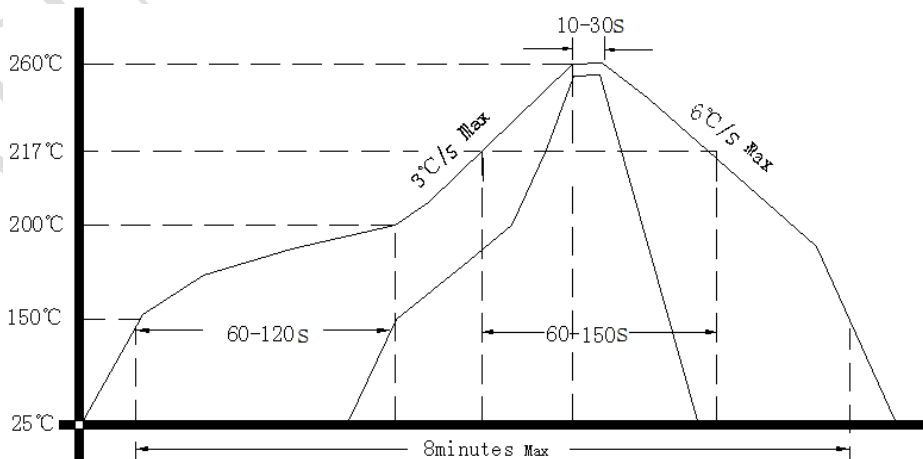



4、 Package: Tape & Reel (mm)

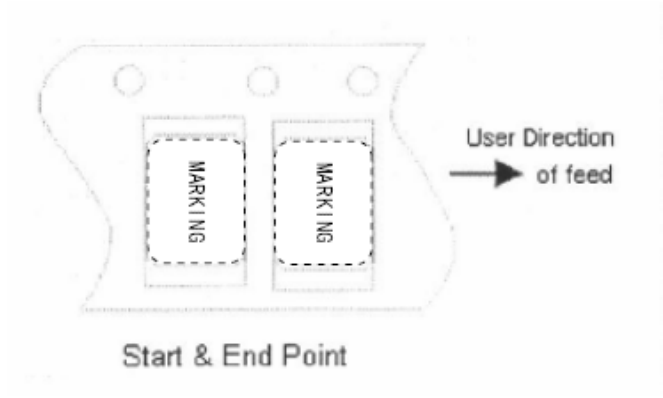
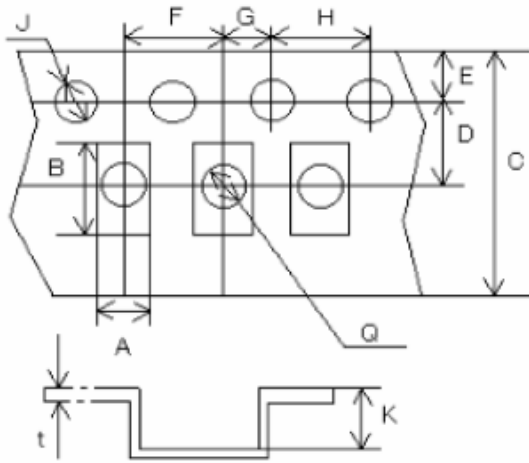

A	B	C	D	E	F	G	H	J	K	t
2.7	3.4	8.0	3.5	1.75	4.0	2.0	4.0	1.55	1.4	0.25

DAPU Confidential

FOR 华峰测控