

Customer Code : _____

DATASHEET

DAPU P/N: **O22A-K426-40.00MHz**

Customer P/N: _____

DAPU			Customer Approval
Drew	Audited	Approved	Stamp, please! Thanks!
Date: 2020.04.08			

Guangdong Dapu Telecom Technology Co.,Ltd

Bldg13-16,.N.Ind.Zone,SSL Industry Park, Dongguan City, Guangdong Province, China

TEL: 0086-0769-88010888 FAX: 0086-0769-81800098



1. Electrical Parameters

MODEL: O22A-K426-40.00MHz						
Item	Description	Parameters			Unit	Test Condition
		Min.	Typ.	Max.		
Output	Frequency	40.00			MHz	
	Output Waveform	Sine wave				
	Level	5		9	dBm	
	Load	50			Ω	
	Harmonics Suppression			-40	dBc	
Frequency Stabilities	Frequency Tolerance vs. Operating Temperature Range	-0.02		+0.02	$\times 10^{-6}$	T_A varied from -45°C to 85°C , measurement referenced to frequency observed with $f_{\text{ref}}=(f_{\text{max}}+f_{\text{min}})/2$, $V_{\text{cc}}=5.0\text{V}$, $V_c=1.65\text{V}$, $O_{\text{load}}=50\Omega$, temperature variable speed less than 2°C per minute.
	Initial Frequency Tolerance	-0.03		+0.03	$\times 10^{-6}$	Measurement referenced to frequency observed with $T_A=25^\circ\text{C}$, $V_{\text{cc}}=5.0\text{V}$, $V_c=1.65\text{V} \pm 0.2\text{V}$, and after 15 minutes of operation, within 30 days after ex-works.
	Frequency Tolerance vs. Supply Voltage	-5		+5	$\times 10^{-9}$	measurement referenced to frequency observed $T_A=25^\circ\text{C}$, V_{cc} varied from 4.5V to 5.5V, $V_c=1.65\text{V}$ and $O_{\text{Load}}=50\Omega$.
	Frequency Tolerance vs. Load	-5		+5	$\times 10^{-9}$	5% load change measurement referenced to frequency observed with $T_A=25^\circ\text{C}$, $V_{\text{cc}}=5.0\text{V}$, $V_c=1.65\text{V}$, and $O_{\text{Load}}=50\Omega$.
	Aging Tolerance Per Day	-1.0		+1.0	$\times 10^{-9}$	V_{cc} , V_c , T_A constant measurement referenced to frequency observed with
	Aging Tolerance 1 Year	-0.1		+0.1	$\times 10^{-6}$	$T_A=25^\circ\text{C}$, $V_{\text{cc}}=5.0\text{V}$, $V_c=1.65\text{V}$, and after 30 days of operation.
Power Supply	Supply Voltage	4.5	5.0	5.5	V	
	Steady Consumption			300	mA	@ -45°C
				150	mA	@ 25°C
	Warm up current			500	mA	



Voltage Control Characteristics	Frequency Tuning Range			-0.5	$\times 10^{-6}$	$V_c=0V$. measurement referenced to $V_c=1.65V$
		-0.03		+0.03	$\times 10^{-6}$	$V_c=1.65V \pm 0.2V$. measurement referenced to exactly 40.00MHz
		+0.5			$\times 10^{-6}$	$V_c=3.3V$. measurement referenced to $V_c=1.65V$
	Reference Voltage	3.2	3.3	3.4	V	
	Linearity			10	%	
	Slope	Positive				
	Input Impedance	100			K Ω	
Phase Noise	Phase Noise			-150	dBc/Hz	1KHz
				-155		10KHz
Environmental Conditions	Operable Temperature	-45		+85	$^{\circ}C$	
	Storage Temperature	-55		+105	$^{\circ}C$	
	ESD Level	Human Body Model, class2: 2000V to 4000V; ANSI/ESDA/JEDEC JS-001-2010.				
		Machine Model, class B: 200V to 400V; JEDEC JESD22-A115C.				
	Moisture Sensitivity Level	Not humidity sensitive.				
	Vibration	Test Condition: 0.75mm ;acceleration:10g;10Hz~500Hz, one cycle per 30 min, test 2 hour. (3 times for each 3 directions X , Y , Z), IEC 68-2-06 Test Fc.				
Shock	50g; 11ms; half sine wave (3 times for each 3 directions X, Y, Z), IEC 68-2-27 Test Ea/Severity 50A.					
Full Package Storage	Relative humidity (%)	20%~70%				
	Temperature ($^{\circ}C$)	-10~35 $^{\circ}C$				



2. Mechanical Structure (mm)

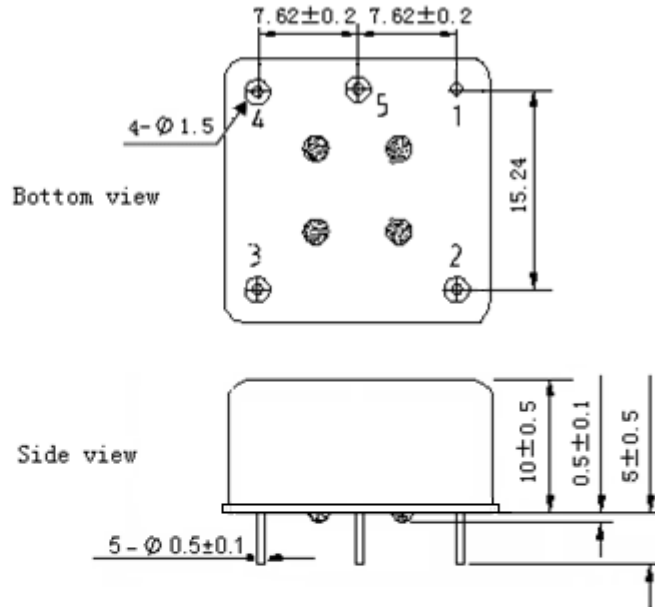

PIN FUNCTION

PIN	NOTATION	FUNCTION
1	GND	GND
2	VC	Control Voltage
3	Vref	Reference Voltage Output
4	VCC	Supply Voltage
5	Output	RF Output

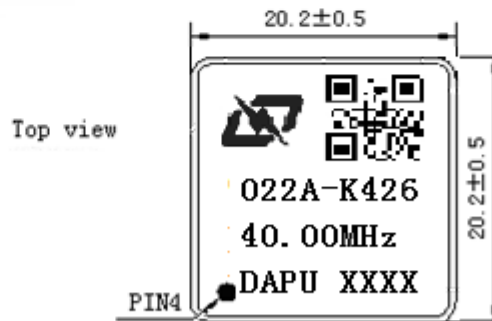

- Note1:** Tolerance $\pm 0.20\text{mm}$ without mark
- Note2:** The first two xx representative: week
After two xx representative: year
- Note3:** Referential weight 8.0g



3. Test Circuit

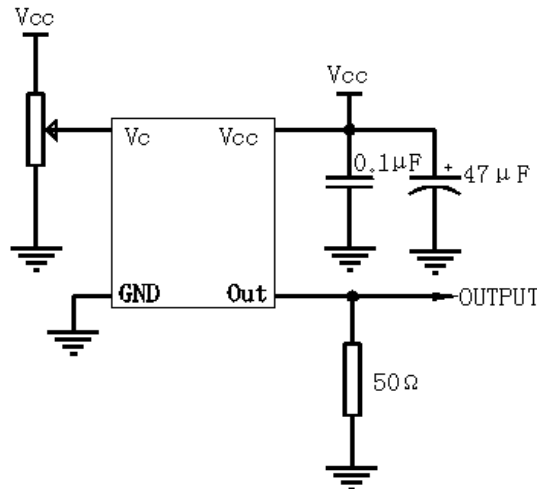

4. Reflow Soldering Curve (RoHS)

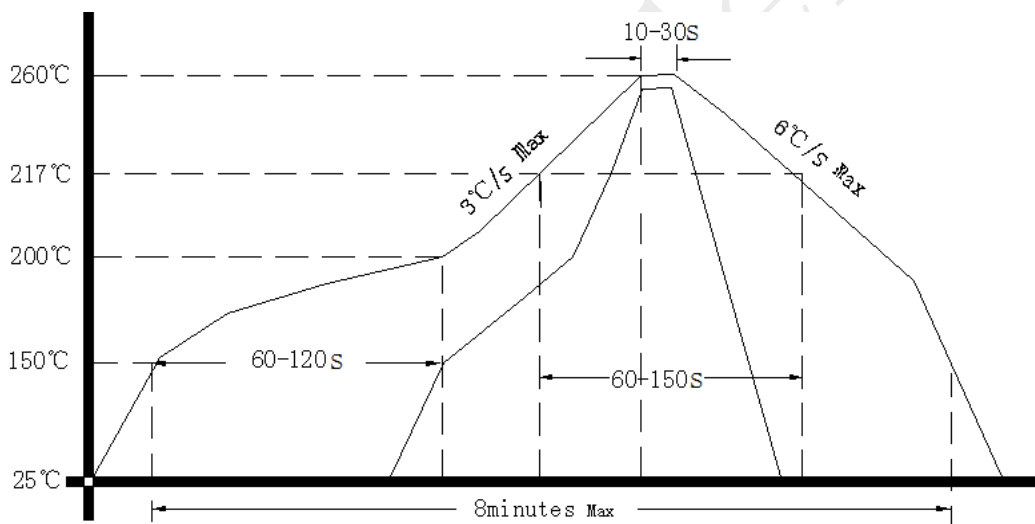

5. Package (mm)

