

Customer Code : _____

DATASHEET

DAPU P/N: **O22S-Y429-120.00MHz**

Customer P/N: _____

DAPU			Customer Approval
Drew	Audited	Approved	<div style="font-size: 2em; opacity: 0.3; transform: rotate(-45deg); position: absolute; top: 50%; left: 50%; pointer-events: none;">FOR 中 科 飞 鸿</div> Stamp, please! Thanks!
Date: 2019.08.23			

Guangdong Dapu Telecom Technology Co.,Ltd

Bldg13-16,.N.Ind.Zone,SSL Industry Park, Dongguan City, Guangdong Province, China

TEL: 0086-0769-88010888 FAX: 0086-0769-81800098



1. Electrical Parameters

MODEL: O22S-Y429-120.00MHz						
Item	Description	Parameters			Unit	Test Condition
		Min.	Typ.	Max.		
Output	Frequency	120.00			MHz	
	Output Waveform	Sine wave				
	Level	6			dBm	
	Load	50			Ω	
	Harmonics Suppression			-30	dBc	
	Spurious Suppression			-70	dBc	
Frequency Stabilities	Frequency Tolerance vs. Operating Temperature Range	-0.05		+0.05	$\times 10^{-6}$	T_A varied from -40°C to 70°C , measurement referenced to frequency observed with $f_{\text{ref}}=(f_{\text{max}}+f_{\text{min}})/2$, $V_{\text{cc}}=5.0\text{V}$, $O_{\text{load}}=50\Omega$, temperature variable speed less than 2°C per minute.
	Initial Frequency Tolerance	-0.5		+0.5	$\times 10^{-6}$	Measurement referenced to frequency observed with $T_A=25^{\circ}\text{C} \pm 2^{\circ}\text{C}$, $V_{\text{cc}}=5.0\text{V}$, and after 15 minutes of operation, within 30 days after ex-works.
	Short-Term Stability: Allan Variance			0.01	$\times 10^{-9}$	Temperature stability, no EMI/EMC or other interference, test after power for 1hour ref. to 25°C ; 1s, using PN9000 equipment.
	Aging Tolerance per day	-5		+5	$\times 10^{-9}$	V_{cc}, V_c, T_A constant Measurement referenced to frequency observed with $T_A=25^{\circ}\text{C}, V_{\text{cc}}=5.0\text{V}, O_{\text{load}}=50\Omega$ and after 30 days of operation.
	Aging Tolerance 1 Year	-0.1		+0.1	$\times 10^{-6}$	
Power Supply	Supply Voltage	4.75	5	5.25	V	
	Current Consumption			300	mA	@ $25^{\circ}\text{C} \pm 2^{\circ}\text{C}$
	Current Consumption during warm up			700	mA	@ $25^{\circ}\text{C} \pm 2^{\circ}\text{C}$
Phase Noise	Phase Noise			-150	dBc/Hz	1KHz



Environmental Conditions	Operable Temperature	-40		+70	°C	
	Storage Temperature	-55		+85	°C	
	ESD Level	Human Body Model, class2: 2000V to 4000V; ANSI/ESDA/JEDEC JS-001-2010.				
		Machine Model, class B: 200V to 400V; ANSI/ESDA/JEDEC JS-001-2010.				
	Moisture Sensitivity Level	Not humidity sensitive.				
	Vibration	Test Condition: 0.75mm ;acceleration:10g;10Hz~500Hz, one cycle per 30 min, test 2 hour. (3 times for each 3 directions X ,Y , Z), IEC 68-2-06 Test Fc.				
Shock	50g; 11ms; half sine wave (3 times for each 3 directions X ,Y, Z),IEC 68-2-27 Test Ea/Severity 50A.					
Full Package Storage	Relative humidity (%)	20%~70%				
	Temperature (°C)	-10~35°C				



2. Mechanical Structure (mm)

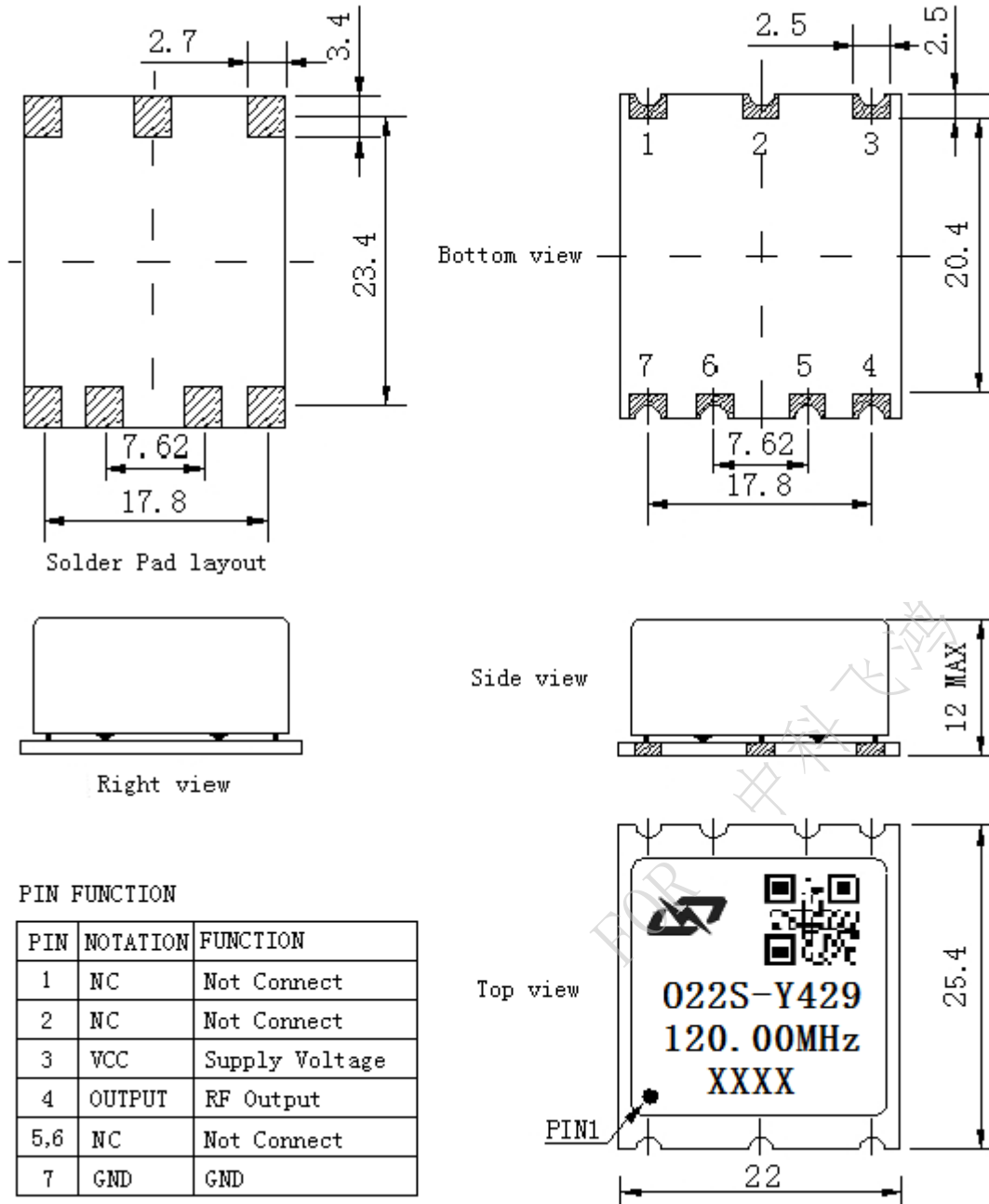

Note1: Tolerance $\pm 0.2\text{mm}$ without mark

Note2: The first two xx representative: week
After two xx representative: year

Note3: Referential Weight 30g

Note4: NC is not connect



3. Test Circuit

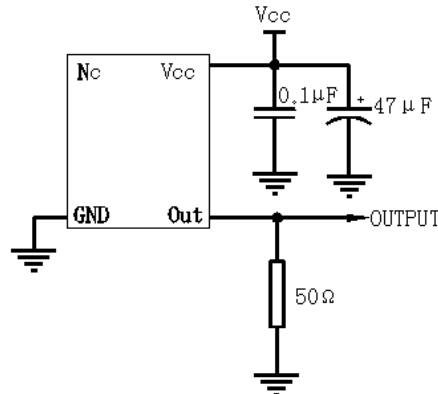

4. Reflow Soldering Curve (RoHS)

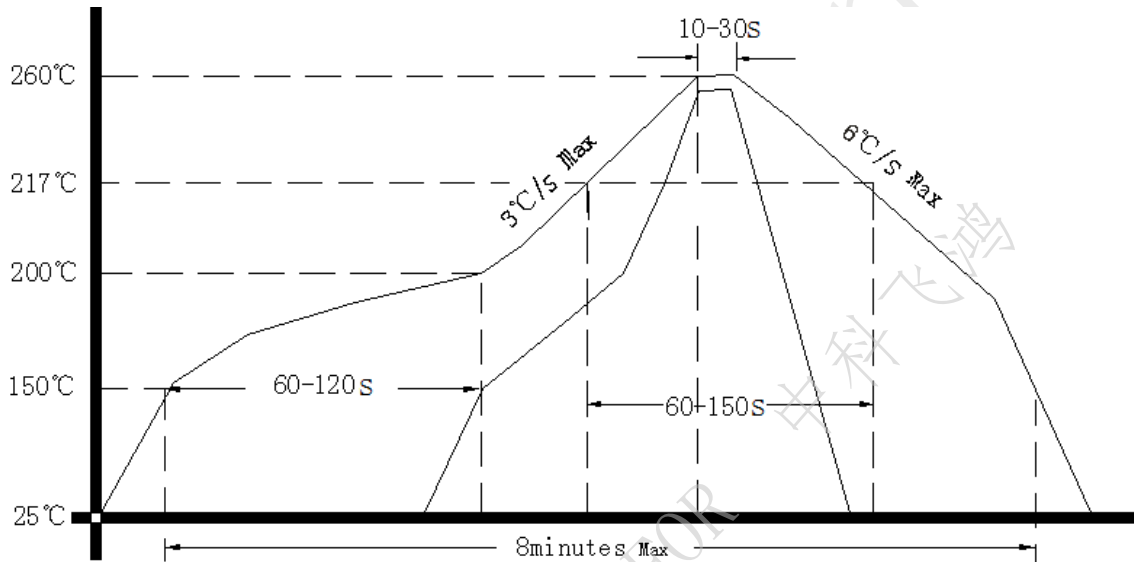

5. Package(mm)

