

Customer Code : \_\_\_\_\_

# DATASHEET

DAPU P/N: T12A-F429-100.00MHz

Customer P/N: \_\_\_\_\_

DAPU			Customer Approval
Drew	Audited	Approved	Stamp, please! Thanks!
Date: 2020.05.15			

## Guangdong Dapu Telecom Technology Co.,Ltd

Bldg13-16,.N.Ind.Zone,SSL Industry Park, Dongguan City, Guangdong Province, China

TEL: 0086-0769-88010888 FAX: 0086-0769-81800098





## 1. Electrical Parameters

MODEL: T12A-F429-100.00MHz						
Item	Description	Parameters			Unit	Test Condition
		Min.	Typ.	Max.		
Output	Frequency	100.00			MHz	
	Output Waveform	Sine Wave				
	Level	+4	+7		dBm	V <sub>cc</sub> = 5.0V, O <sub>load</sub> =50Ω.
	Harmonics Suppression		-30	-25	dBc	V <sub>cc</sub> = 5.0V, O <sub>load</sub> =50Ω.
	Spurious Suppression		-80		dBc	
	Load	50			Ω	
Frequency Stabilities	Frequency Tolerance vs. Operating Temperature Range	-0.5		+0.5	× 10 <sup>-6</sup>	T <sub>A</sub> varied from -40°C to 85°C, measurement referenced to frequency observed with f <sub>ref</sub> =(f <sub>max</sub> +f <sub>min</sub> )/2, V <sub>cc</sub> = 5.0V, temperature variable speed less than 2°C per minute.
	Initial Frequency Tolerance	-1.0		+1.0	× 10 <sup>-6</sup>	Measurement referenced to frequency observed with T <sub>A</sub> =25°C, V <sub>cc</sub> =5.0V, and after 15 minutes of operation, within 30 days after ex-works.
	Frequency Tolerance vs. Supply Voltage	-0.1		+0.1	× 10 <sup>-6</sup>	measurement referenced to frequency observed T <sub>A</sub> =25°C, V <sub>cc</sub> varied from 4.75V to 5.25V, and O <sub>load</sub> =50Ω.
	Frequency Tolerance vs. Load	-0.1		+0.1	× 10 <sup>-6</sup>	5% load change measurement referenced to frequency observed with T <sub>A</sub> =25°C, V <sub>cc</sub> =5.0V, and O <sub>load</sub> =50Ω.
	Aging Tolerance First Year	-1		+1	× 10 <sup>-6</sup>	V <sub>cc</sub> , T <sub>A</sub> constant measurement referenced to frequency observed with T <sub>A</sub> =25°C, V <sub>cc</sub> = 5.0V, and after 30 days of operation.
Power Supply	Current Consumption			40	mA	@ 25°C, V <sub>cc</sub> =5.0V, O <sub>load</sub> =50Ω.
	Supply Voltage	4.75	5.0	5.25	V	



Jitter	Phase Jitter		0.4		ps	12KHz to 20MHz
Phase Noise	Phase Noise		-80		dBc/Hz	10Hz
			-110			100Hz
			-140			1KHz
			-155			10KHz
			-160			100KHz
Environmental Conditions	Operable Temperature	-40		+85	°C	
	Storage Temperature	-55		+105	°C	
	ESD Level	Human Body Model, class2: 2000V to 4000V; ANSI/ESDA/JEDEC JS-001-2010.				
		Machine Model, class B: 200V to 400V; JEDEC JESD22-A115C.				
	Moisture Sensitivity Level	Not humidity sensitive.				
	Vibration	Test Condition: 0.75mm ;acceleration:10g;10Hz~2000Hz, one cycle per 30 min, test 2 hour. (3 times for each 3 directions X , Y , Z) .IEC 68-2-06 Test Fc.				
Shock	100g; 6ms; half sine wave (3 times for each 3 directions X ,Y, Z ),IEC 68-2-27 Test Ea/Severity 50A.					
Full Package Storage	Relative humidity (%)	20%~70%				
	Temperature (°C)	-10~35°C				



## 2. Mechanical Structure(mm)

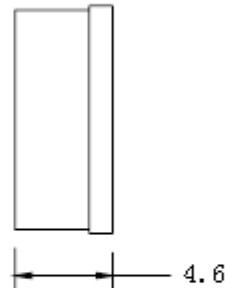
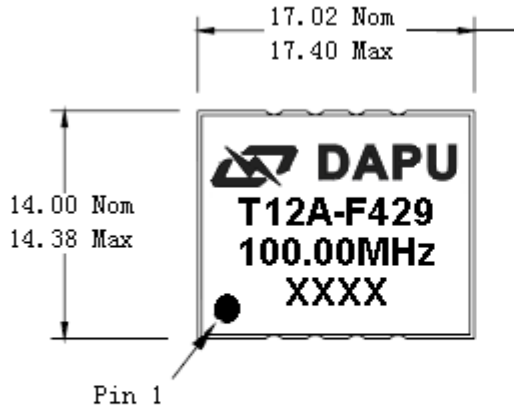

### PIN CONNECTIONS

1	Supply Voltage
2	N/C
3	Gnd
4	Gnd
5	Output
6	N/C
7	N/C
8	N/C

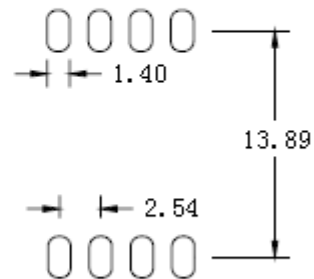
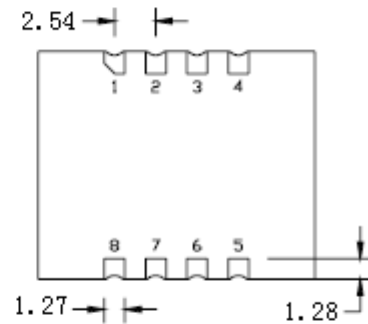

Recommended land pattern based on IPC-7351

- Note1:** Tolerance  $\pm 0.20\text{mm}$  without mark  
**Note2:** The first two xx representative: week  
 After two xx representative: year



### 3. Test circuit

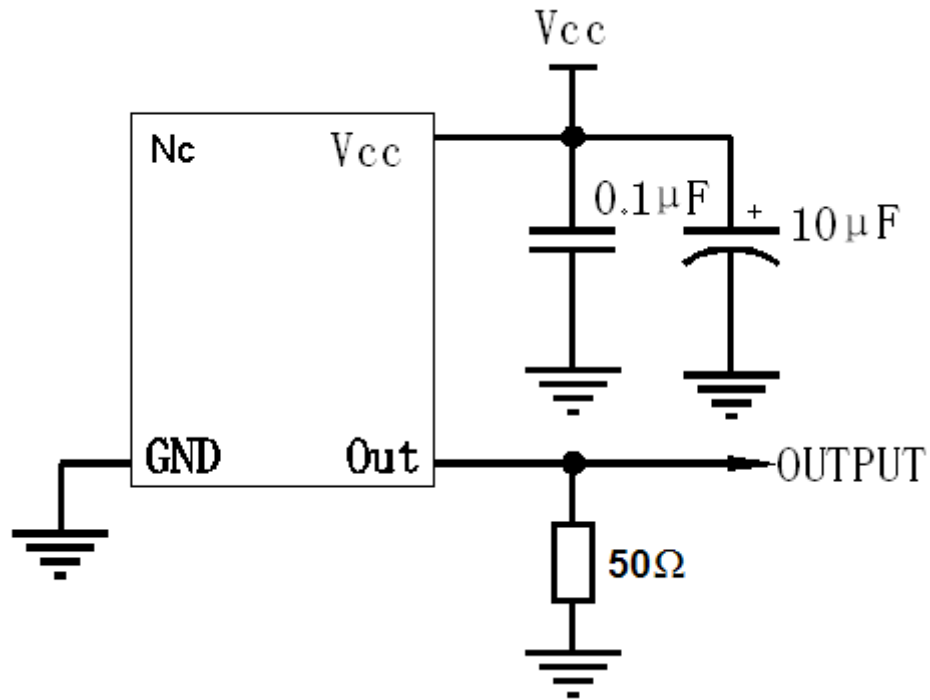

### 4. Reflow Soldering Curve (RoHS)

