

Customer Code : _____

DATASHEET

DAPU P/N: 022A-K427-19.20MHz-A

Customer P/N: _____

DAPU			Customer Approval
Drew	Audited	Approved	Stamp, please! Thanks!
Date: 2019.06.04			

Guangdong Dapu Telecom Technology Co.,Ltd

Bldg 16,.N.Ind.Zone,SSL Industry Park, Dongguan City, Guangdong Province, China

TEL: 0086-0769-88010888 FAX: 0086-0769-81800098



1. Electrical Parameters

MODEL: O22A-K427-19.20MHz-A						
Item	Description	Parameters			Unit	Test Condition
		Min.	Typ.	Max.		
Output	Frequency	19.20			MHz	
	Output Waveform	Sine wave				
	Level	7	9	11	dBm	
	Load	50			Ω	
	Harmonics Suppression			-30	dBc	
	Spurious Suppression			-60	dBc	
Frequency Stabilities	Frequency Tolerance vs. Operating Temperature Range	-3		+3	$\times 10^{-9}$	T_A varied from -40°C to 70°C , measurement referenced to frequency observed with $f_{ref}=(f_{max}+f_{min})/2$, $V_{cc}=5.0\text{V}$, $V_c=2.0\text{V}$, $O_{load}=50\Omega$, temperature variable speed less than 2°C per minute.
	Initial Frequency Tolerance	-0.1		+0.1	$\times 10^{-6}$	Measurement referenced to frequency observed with $T_A=25^\circ\text{C} \pm 3^\circ\text{C}$, $V_{cc}=5.0\text{V}$, $V_c=2.0\text{V}$ and after 15 minutes of operation, before shipment.
	Frequency Tolerance vs. supply voltage	-0.5		+0.5	$\times 10^{-9}$	measurement referenced to frequency observed $T_A=25^\circ\text{C}$, V_{cc} varied from 4.75V to 5.25V, $V_c=2.0\text{V}$, $O_{load}=50\Omega$.
	Frequency Tolerance vs. Load	-0.5		+0.5	$\times 10^{-9}$	5% Load Change Measurement referenced to frequency observed with $T_A=25^\circ\text{C}$, $V_{cc}=5.0\text{V}$, $V_c=2.0\text{V}$, $O_{load}=50\Omega$.
	Short Term Stability			0.01	$\times 10^{-9}$	Temperature stability, no EMI\EMC or other interference, test after power for 1hour ref. to 25°C ; 1s, using PN9000 equipment.
	Aging Tolerance per day	-0.3		+0.3	$\times 10^{-9}$	V_{cc}, V_c, T_A constant Measurement referenced to frequency observed with $T_A=25^\circ\text{C}, V_{cc}=5.0\text{V}, V_c=2.0\text{V}, O_{load}=50\Omega$ and after 14 days of operation.
	Aging Tolerance 1Year	-0.03		+0.03	$\times 10^{-6}$	
	Aging Tolerance 15Year	-0.3		+0.3	$\times 10^{-6}$	
Power Supply	Supply Voltage	4.75	5.0	5.25	V	
	Steady Consumption		140	230	mA	@ 25°C
	Warm up current		500	600	mA	@ 25°C
	Warm-Up Time			3	min	@ 25°C within $\pm 0.05 \times 10^{-6}$ of final frequency with reference after 1 hour on.



Voltage Control Characteristics	Frequency Tuning Range	-1.0		-0.5	$\times 10^{-6}$	$V_c=0V$. measurement referenced to $V_c=2.0V$.
		-0.1		+0.1	$\times 10^{-6}$	$V_c=2.0V$. measurement referenced to exactly 19.20MHz.
		+0.5		+1.0	$\times 10^{-6}$	$V_c=4.0V$. measurement referenced to $V_c=2.0V$.
	Linearity			10	%	
	Slope	Positive				
	Input Impedance	100				K Ω
Phase Noise	Phase Noise		-90	-85	dBc/Hz	1Hz
			-115	-110		10Hz
			-145	-140		100Hz
			-161	-155		1KHz
			-167	-160		10KHz
			-168	-165		100KHz
			-168	-165		1MHz
Environmental Conditions	Operable Temperature	-40		+70	$^{\circ}C$	
	Limit operating temperature	-55		+90	$^{\circ}C$	
	Storage Temperature	-55		+105	$^{\circ}C$	
	ESD Level	Human Body Model, class2: 2000V to 4000V; ANSI/ESDA/JEDEC JS-001-2010.				
		Machine Model, class B: 200V to 400V; ANSI/ESDA/JEDEC JS-001-2010.				
	Moisture Sensitivity Level	Not humidity sensitive.				
	Humidity	95% RH @+40 $^{\circ}C$, 240H. GJB30A-96 Test 103				
Vibration	Test Condition: 0.75mm ; 10Hz~55Hz,GJB30A-96 Test 201.					
Shock	30g; 11ms; half sine wave (3 times for each 3 directions X ,Y, Z), GJB30A-96 Test 213					
Full Package Storage	Relative humidity (%)	20% ~70%				
	Temperature ($^{\circ}C$)	-10~35 $^{\circ}C$				



2. Mechanical Structure (mm)

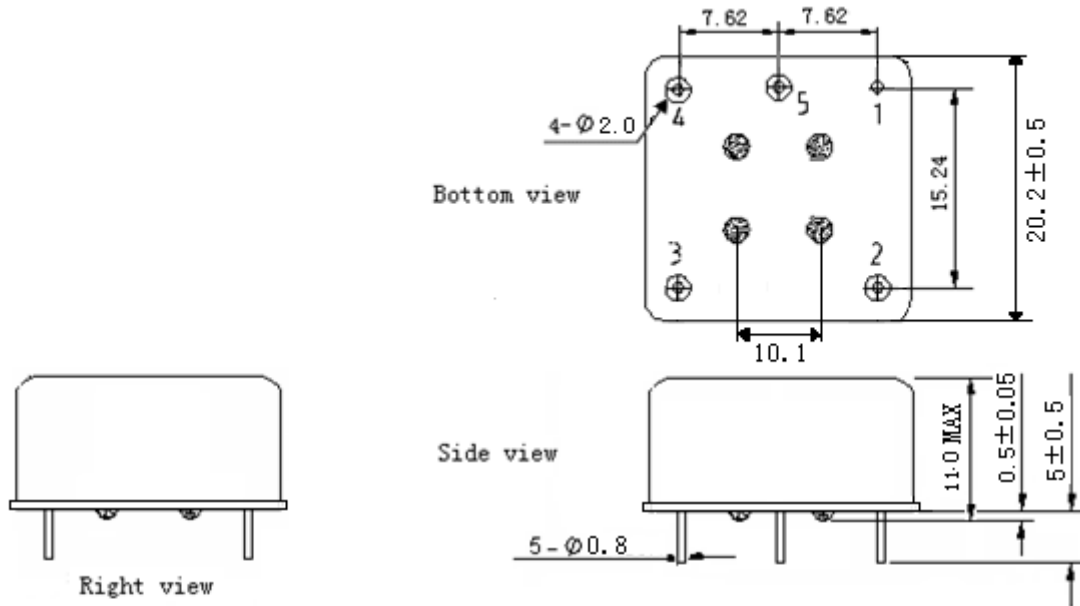

PIN FUNCTION

PIN	NOTATION	FUNCTION
1	GND	GND
2	OUTPUT	RF Output
3	VCC	Supply Voltage
4	VC	Control Voltage
5	NC	Not Connect

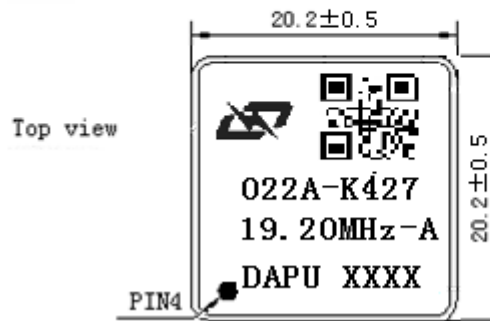

- Note1:** Tolerance ±0.20mm without mark
- Note2:** The first two xx representative: week
After two xx representative: year
- Note3:** Referential weight 8.0g
- Note4:** NC is not connect



3. Test Circuit

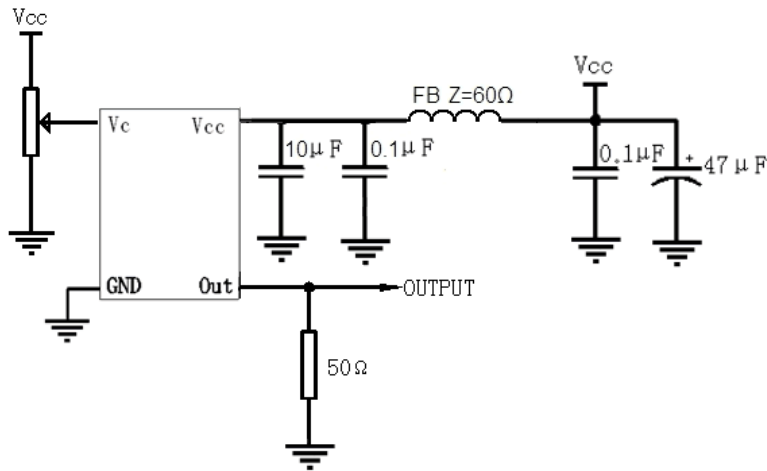

4. Reflow Soldering Curve (RoHS)

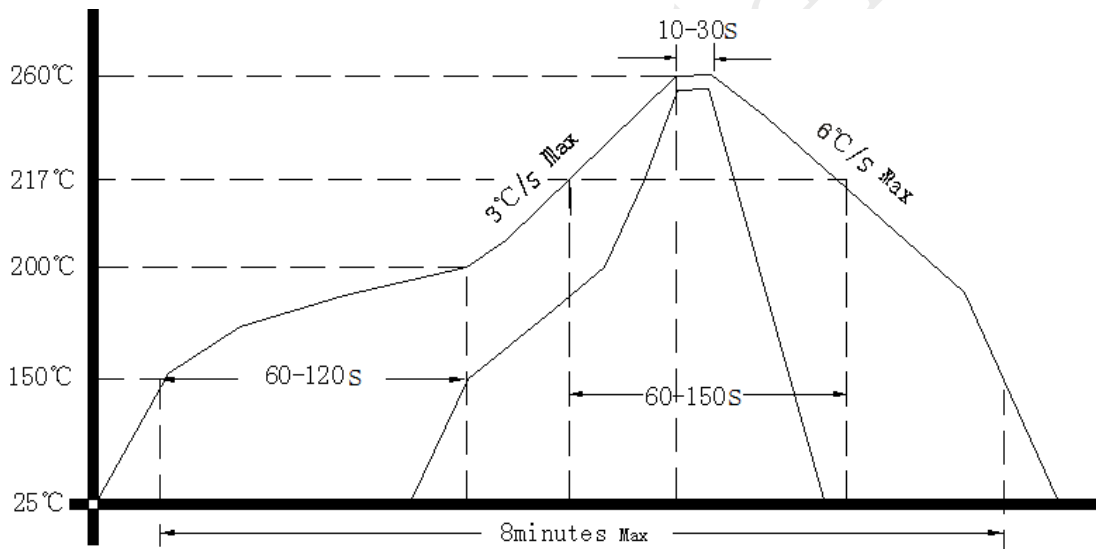

5. Package(mm)

